

CATALOG SUPPLEMENT "I-I"

WITH
NEW PARTS & UNITS

FOR

JACK POT



Williams[®] ELECTRONICS, INC.
SUBSIDIARY OF THE SEEBURG CORPORATION

3401 N. California Ave.
Phone 267-2240

Chicago, Ill. 60618, U.S.A.
Cable Address: Wilcoin

D-7251 10 STEP 3" DRUM UNIT

WITH PRINTED CIRCUIT AND CONTACT RING

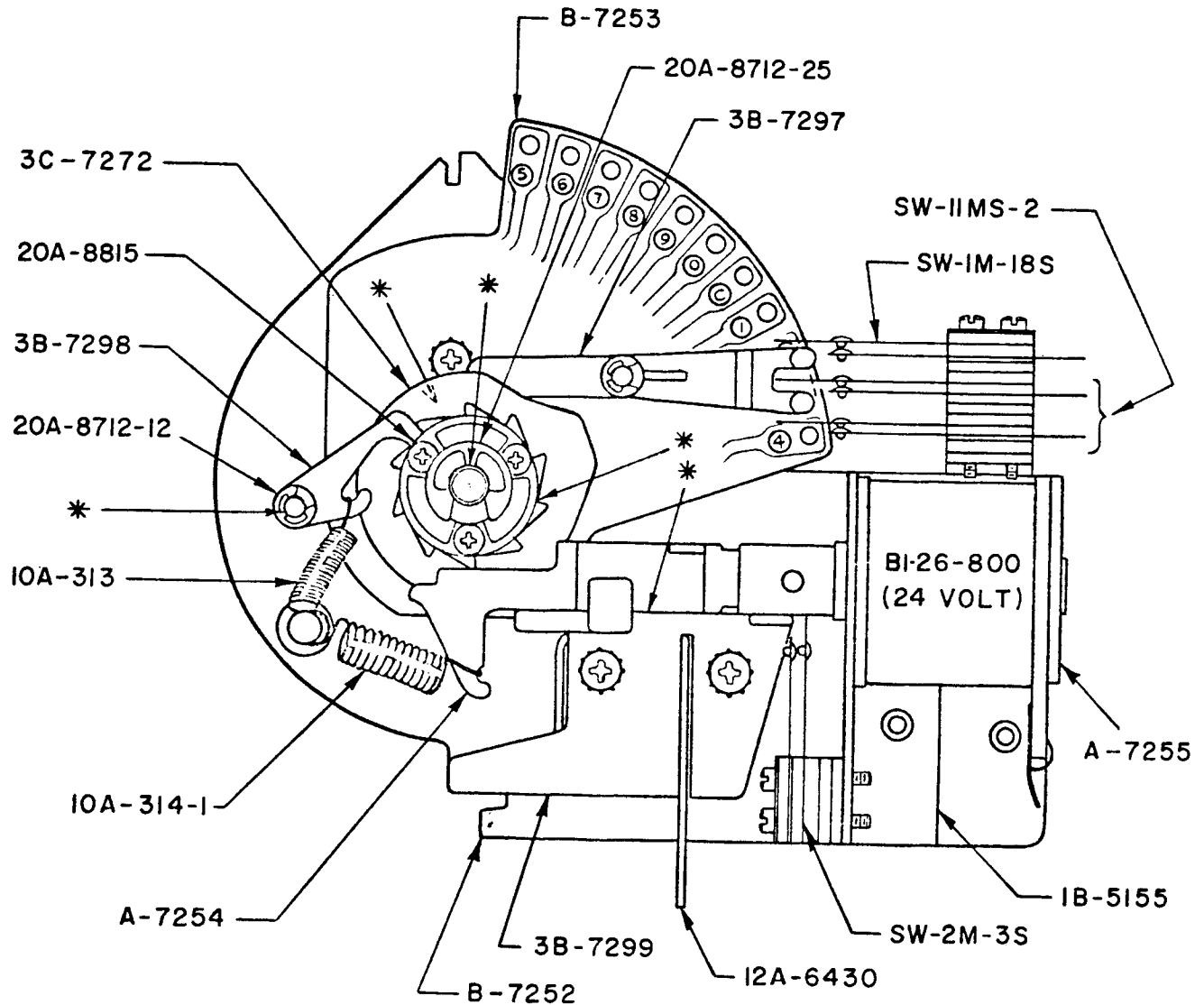

LUBRICATION :

DO NOT PUT LUBRICANT ON DRIVE ARMATURE.

PROPER LUBRICATION WILL INSURE A LONGER LASTING AND BETTER OPERATING UNIT.

POINTS TO BE LUBRICATED ARE THE THREE POSTS ON WHICH THE NYLON PARTS ROTATE, EACH TOOTH OF THE RATCHET, ALSO RATCHET CAM AND TOP OF DRIVE PAWL-BRACKET, INDICATED BY *.

" SERVICE SUGGESTION."

IF UNIT BECOMES SLUGGISH-DISASSEMBLE, CLEAN ALL PARTS AND REASSEMBLE, LUBRICATING ALL PARTS MARKED WITH *.

D-7251 10 STEP 3" DRUM UNIT

WITHOUT PRINTED CIRCUIT AND CONTACT RING.

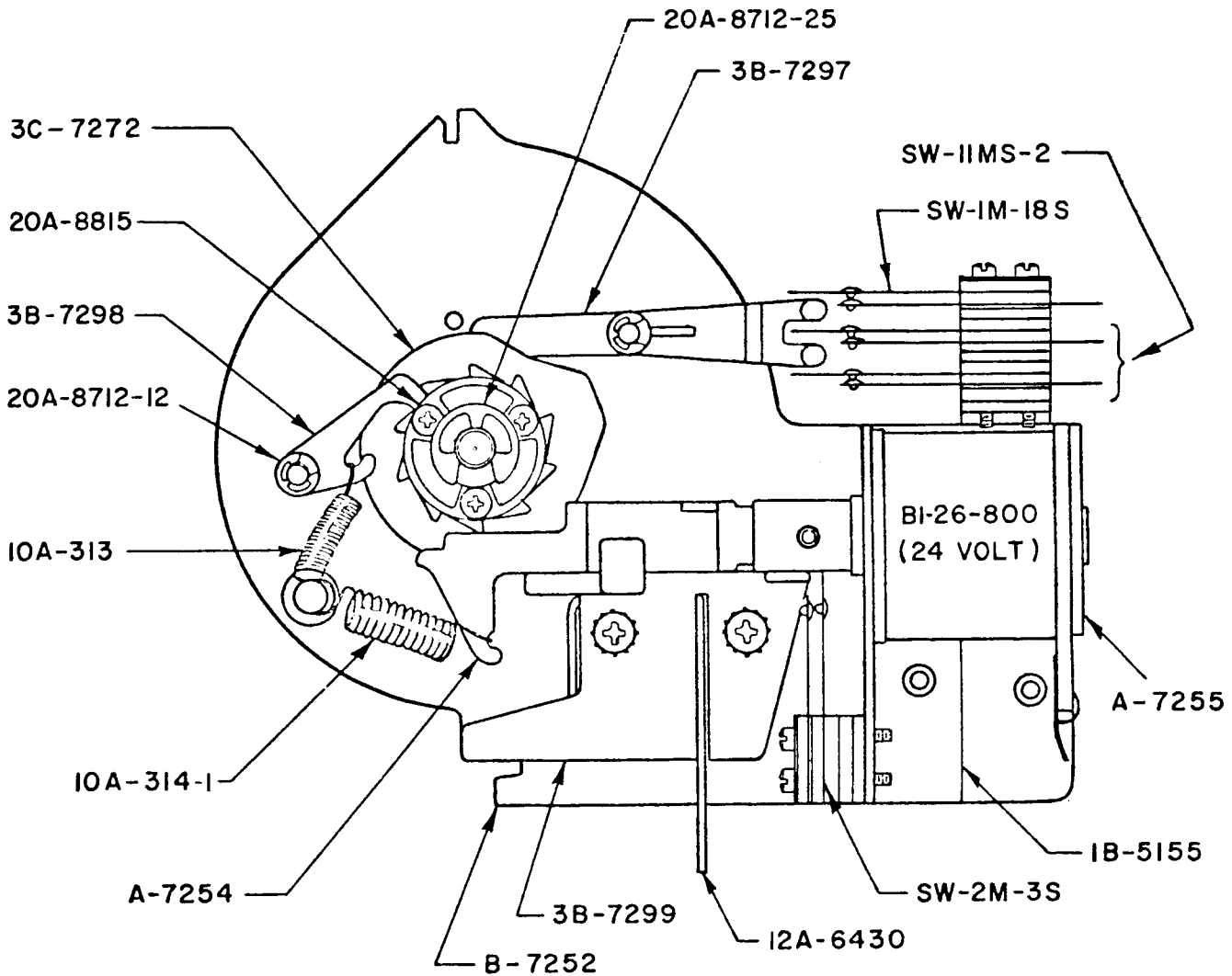

SWITCH ADJUSTMENT :

AT "O" OR INDEX POSITION ALL 3 SWITCHES ARE OPEN AS SHOWN.

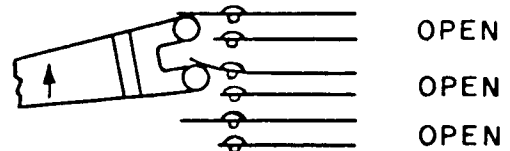

AT 1ST TO 8TH POSITION 2 TOP SWITCHES ARE CLOSED. BOTTOM SWITCH REMAINS OPEN.

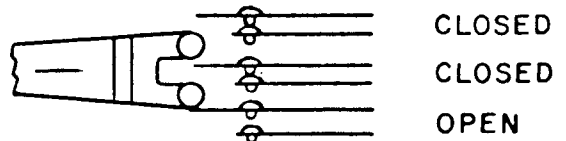

AT 9TH POSITION ALL 3 SWITCHES ARE CLOSED, AS SHOWN.

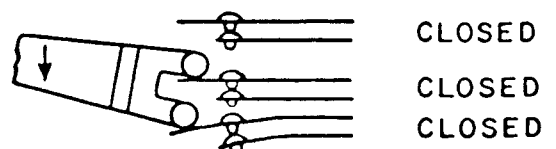

10 STEP UNIT PARTS

3" DRUM UNIT

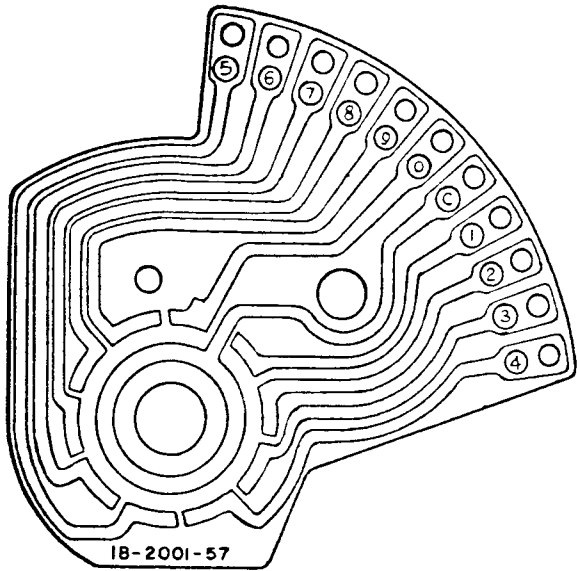

B-7253

PRINTED CIRCUIT ASSEMBLY
* LUBRICATE

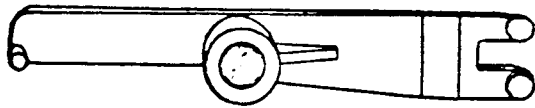
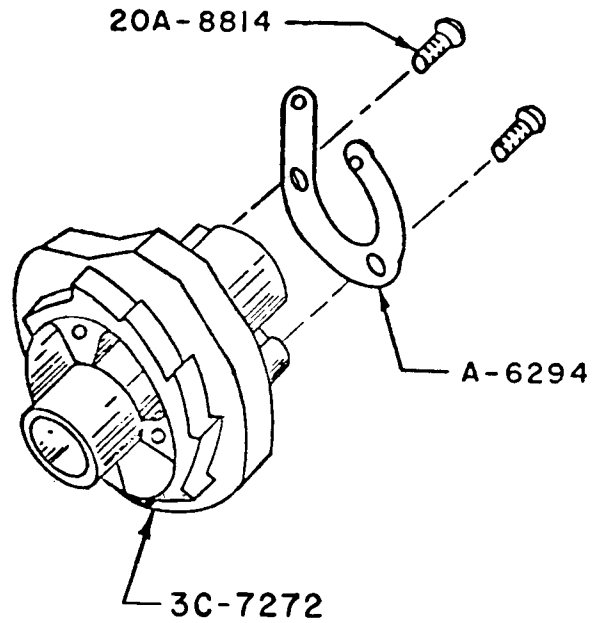

3B-7297
SWITCH ACTUATOR

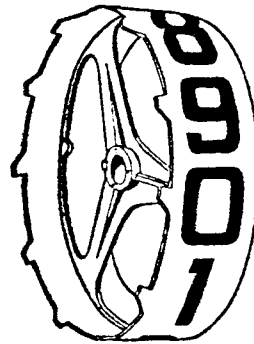

30B-7295-1
SCORE REEL

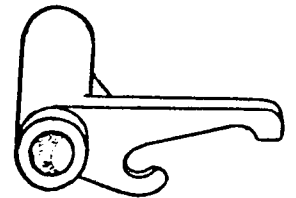

3B-7298
RATCHET STOP PAWL

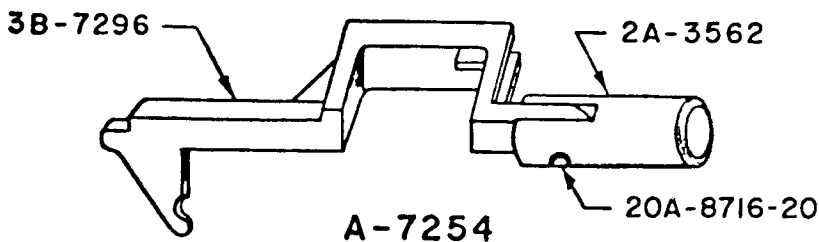

A-7254
DRIVE PAWL & ARMATURE

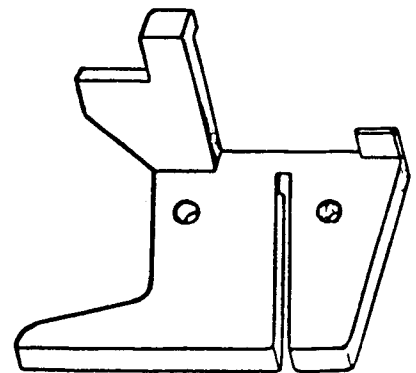

3B-7299
BRACKET-DRIVE PAWL

SPECIAL 3" DRUM REELS M'T'D. ON PLAYFIELD

1st USED ON JACK POT & GOLD RUSH

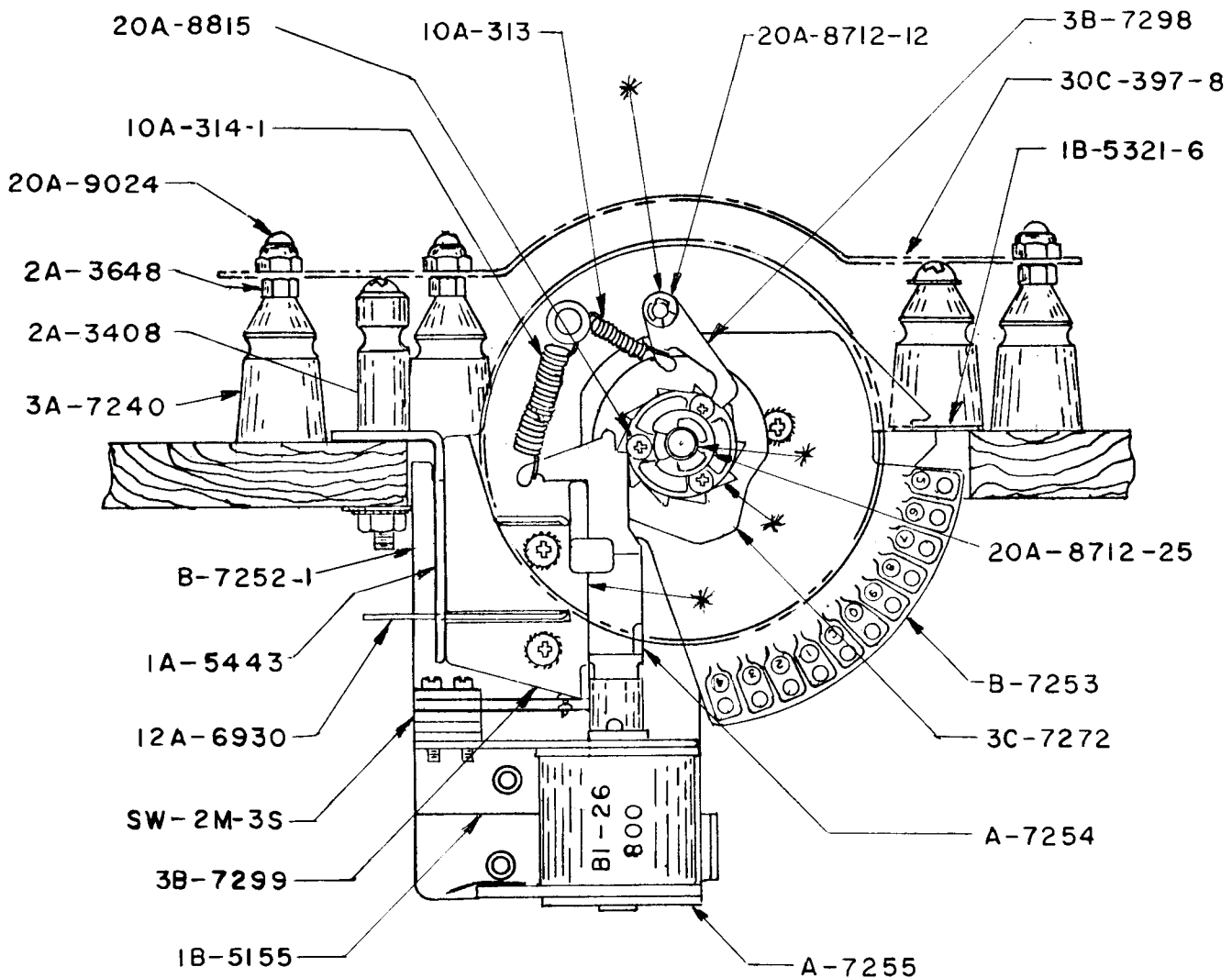

LUBRICATION :

DO NOT PUT LUBRICANT ON DRIVE ARMATURE.

PROPER LUBRICATION WILL INSURE A LONGER LASTING AND BETTER OPERATING UNIT.

POINTS TO BE LUBRICATED ARE THE THREE POSTS ON WHICH THE NYLON PARTS ROTATE, EACH TOOTH OF THE RATCHET, ALSO RATCHET CAM AND TOP OF DRIVE PAWL-BRACKET, INDICATED BY *.

" SERVICE SUGGESTION."

IF UNIT BECOMES SLUGGISH - DISASSEMBLE, CLEAN ALL PARTS AND REASSEMBLE, LUBRICATING ALL PARTS MARKED WITH *.

SPECIAL 3" DRUM REELS
M'T'D. ON PLAYFIELD

1ST USED ON JACK POT & GOLD RUSH

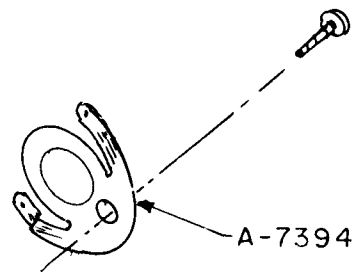
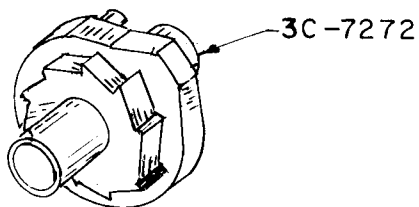

RATCHET AND WIPER ASSEMBLY (A-7394)
 FOR LEFT AND CENTER REELS

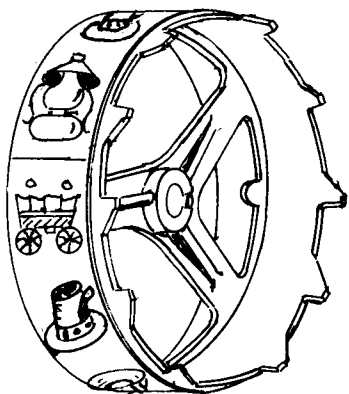

30C-397-11
 STRIP USED

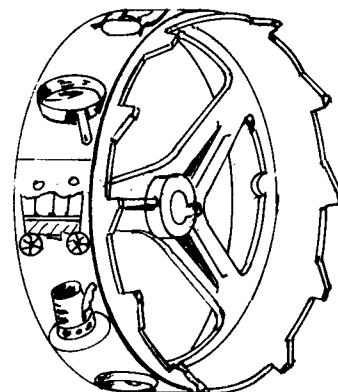

30C-397-12
 STRIP USED

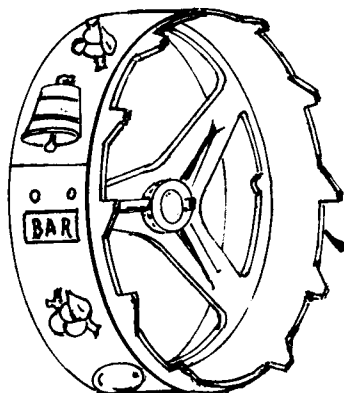

30C-397-9
 STRIP USED

7A-6688-1

3C-7295-1

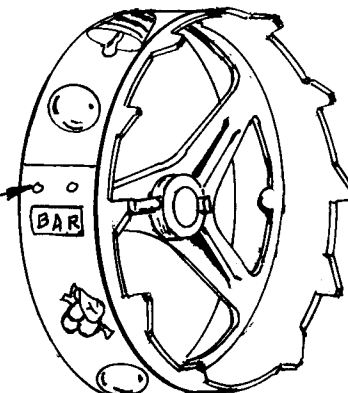

30C-397-10
 STRIP USED

3" DRUM & REEL STRIP ASSEMBLIES
 C-7402

PRICE LIST

ARRANGED IN NUMERICAL ORDER

<u>Part No.</u>	<u>Description</u>	<u>Price</u>
1B-5155	Plunger & Coil Bracket.....	.92
1B-5321-6	Lower Mounting Bracket(Reels Playfield).....	2.10
1A-5443	Upper mounting Bracket(Reels-Playfield).....	.44
2A-3408	Metal Post.....	.40
2A-3562	Plunger.....	.86
2A-3648	Post Fastening Screw.....	.32
3A-7240	Small Red Plastic Post.....	.12
3C-7272	Ratchet & Cam.....	.12
3C-7295-1	3" Drum Reel w/Holes for Riveting Reel Strip	.60
3B-7296	Drive Pawl.....	.12
3B-7297	Switch Actuator.....	.12
3B-7298	Stop Pawl.....	.10
3B-7299	Bracket Drive Pawl.....	.16
7A-6688-1	Rivet for Reel Strips.....	.02
10A-313	Spring - Ratchet & Stop Pawl22
10A-314-1	Spring - Drive Arm.....	.20
12A-6430	Wire Form - Latch.....	.08
20A-8712-12	"E" Retaining Ring.....	.02
20A-8712-25	"E" Retaining Ring.....	.02
20A-8716-20	Roll Pin - 1/8 X 3/8.....	.02
20A-8814	#4 X 1/2 R.H. Phillips M. Screw.....	.02
20A-8815	#4 X 3/8 R.H. Phillips M. Screw.....	.02
20A-9024	Hex Nut with Nylon Cap.....	.12
30C-397-8	Screened & Vacuum Formed Cover.....	11.50
30C-397-9	3" Reel Strip - Fruit Symbol.....	1.50
30C-397-10	3" Reel Strip - Fruit Symbol.....	1.50
30C-397-11	3" Reel Strip - Prospector Symbol.....	1.50
30C-397-12	3" Reel Strip - Prospector Symbol.....	1.50
30B-7295-1	3" Score Reel - Screened Back Box.....	.80
A-6294	Contact Ring - Score Reel.....	.24
D-7251	10 Step Unit - 3" Drum w/Printed Circuit....	20.44
D-7251	10 Step Unit - 3" Drum w/out Printed Circuit	18.22
B-7252	Base Plate 3" Score Reels (Back Box).....	3.12
B-7252-1	Base Plate 3" Spinning Reels (Playfield)....	2.10
B-7253	Printed Circuit.....	1.42
A-7254	Drive Pawl & Arm.....	1.26
A-7255	Coil Stop.....	1.42
A-7394	Contact Ring - Spinning Reels.....	.24
C-7402	3" Drum Reel & Strip Assembly Playfield.....	2.50
B1-26-800	Coil.....	2.00
SW-1M-18S	Switch.....	.50
SW-11MS-2	Switch.....	.84
SW-2M-3S	Switch.....	.60