

# Instruction Manual

*for*

# CABARET

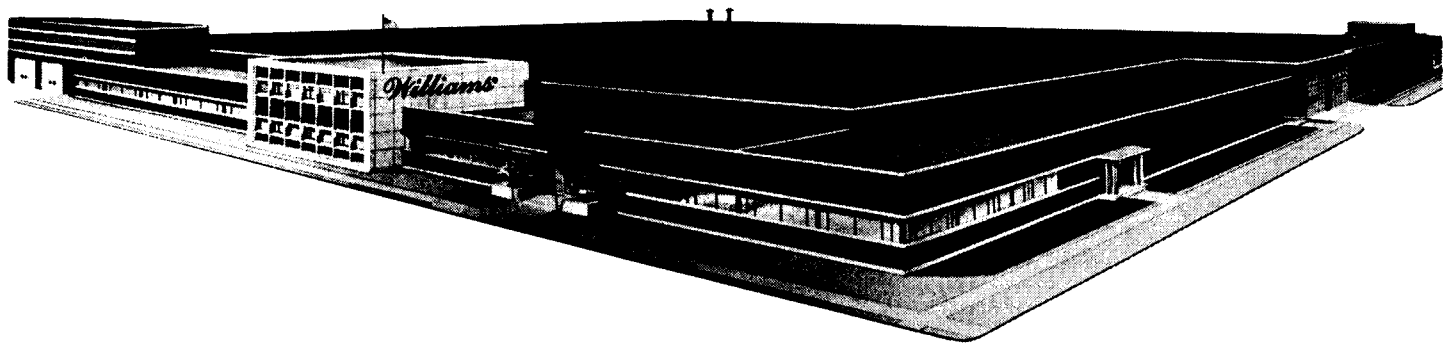

*Williams*<sup>®</sup> ELECTRONICS, INC.  
SUBSIDIARY OF THE SEEBURG CORPORATION

3401 N. California Ave.  
Phone 267-2240

Chicago, Ill. 60618, U.S.A.  
Cable Address: Wilcoin

# ***IMPORTANT NOTICE***

---

---

**KINDLY INFORM LOCATIONS THAT THEY CAN TURN DISPLAY LIGHTS ON BY PRESSING LEFT FLIPPER BUTTON. MACHINE CAN STILL BE SHUT OFF BY TAPPING BOTTOM OF CABINET.**

**MASTER SWITCH (ON-OFF) IS LOCATED UNDERNEATH FRONT PART OF CABINET.**

# CAUTION!

The playboard on this machine has an improved finish with excellent wearing properties. Do not under any circumstances clean the board with water, water soap solutions or harsh abrasives. Avoid such things as steel wool, kitchen cleansers or abrasive hand soap. Water will weaken the adhering of the paint to the board and abrasives shorten the board life by many thousand plays. A wax base cleaner with negligible abrasive qualities used lightly, but frequently, will extend the board life to its full capabilities.

---

## **SERVICEMAN TO REMOVE BACKGLASS:**

- WITH BACK DOOR REMOVED, PULL BACK ON BRACKETS AT INSIDE TOP OF LITE BOX.**
- FROM THE FRONT OF GAME, LIFT GLASS UP AND OUT.**

# INSTRUCTIONS FOR ALTERING COIN CHUTES EQUIPPED WITH A FLIP-OVER DEVICE.

FOR 1 COIN - FOR 1 PLAY

OR

2 COINS - FOR 1 PLAY

**FIGURE 1**

**FIGURE 2**

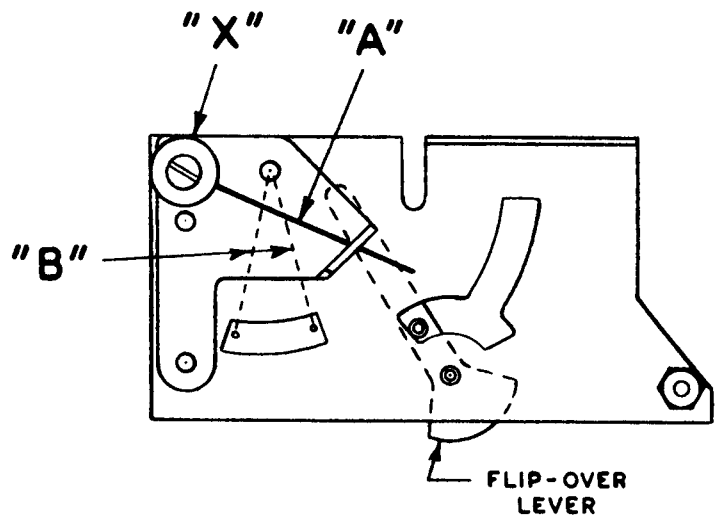
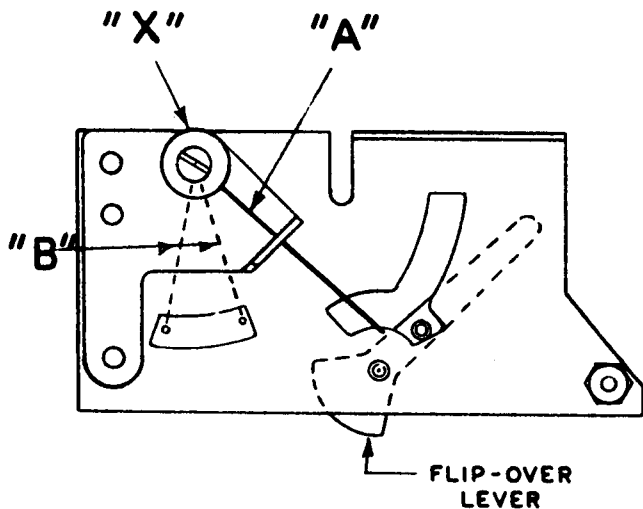

## **1 COIN - FOR 1 PLAY (FIGURE 1):**

Wire form "A" should be in position as shown in Figure 1. Flip-over lever should rebound from wire form "A" and return to position shown in Figure 1 everytime a coin is inserted. All coins pass over the coin trip switch wire "B".

## **2 COINS - FOR 1 PLAY (FIGURE 2):**

Wire form "A" should be in position as shown in Figure 2 (see note). Flip-over lever should alternate from side to side. 1st coin should go to cash box without actuating coin trip switch wire "B", 2nd coin should pass the coin trip switch wire "B" and returns flip-over to position as shown in Figure 2.

### **NOTE:**

To change from 1 coin play to 2 coin play or vice versa - loosen screw "X" and move screw, bushing & wire form "A" to position as required - shown in Figure 1 position as required - shown in Figure 1 or Figure 2.

When using 1 coin for 1 play, wire form "A" should not under any circumstances be allowed to enter the "Banana" slot and cause binding of flip-over lever.

## INSTRUCTIONS FOR COIN TRIP SWITCH ADJUSTMENT

WIRE SHOULD BE IN CONTACT WITH END OF CRESCENT OPENING WHEN BLADE ADJUSTMENT IS MADE.

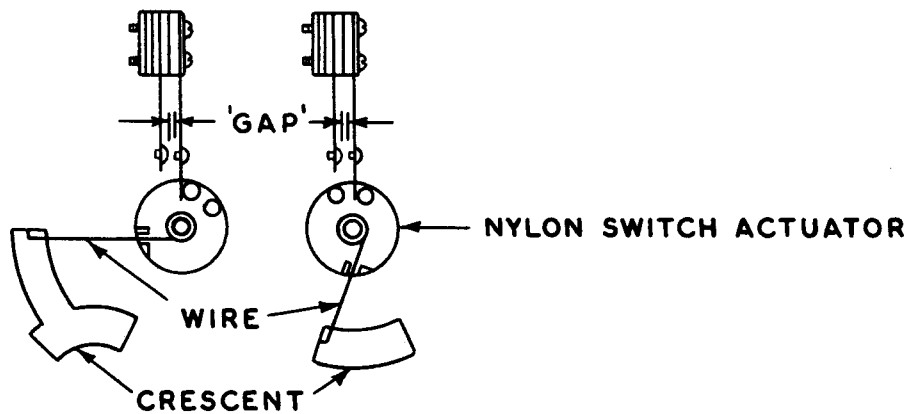

Long blade should be in contact with nylon switch actuator and have a maximum overtravel of  $1/32$ .

or

Using a gram gauge, tension of long blade should not exceed 10 grams.

### SWITCH ADJUSTMENT

1. For small coins, such as dimes, adjust short blade so that the 'gap' between the silver contacts is .045 to .055.
2. For larger & heavier coins the 'gap' should be .045 to .060.
3. Do not adjust 'gap' closer than .040.

# WARRANTY

THE MOTORS IN ALL NEW WILLIAMS PRODUCTS ARE UN-CONDITIONALLY GUARANTEED FOR 6 MONTHS FROM DATE OF PURCHASE.

ANY DEFECTIVE MOTORS RETURNED DURING THE WARRANTY PERIOD WILL BE REPLACED FREE OF CHARGE BY YOUR WILLIAMS DISTRIBUTOR.

## IMPORTANT NOTICE

WHEN ORDERING PARTS ALWAYS SPECIFY NAME OF UNIT, GAME AND SERIAL NUMBER, IN ADDITION TO A CLEAR DESCRIPTION OF THE PART AND PART NUMBER IF POSSIBLE.

### UNIT PARTS LIST FOR "CABARET"

UNIT NAME	CONTACT DISC	WIPER ASSEMBLY	RATCHET GEAR ASSEMBLY	MOTORS
REPLAY	- - - -	- - - -	A-6400	
BALL COUNT	C-6932	C-6520	A-6402-5	
MATCH	C-6879	C-6520	A-6401	14A-7805
PLAYER	C-6417	C-6521	A-6405-3	(60 CYCLE)
COIN	C-6896	C-6520	A-6402-3	
0-9	B-6297	A-6294	3C-7128	
TENS	- - - -	- - - -	3C-7128	14A-7806
HUNDREDS	B-6297	A-6294	3C-7128	(50 CYCLE)
THOUSANDS	B-6297	A-6294	3C-7128	
BONUS	B-6297	A-6294	3C-7128	
ADVANCE	B-6297	A-6294	3C-7128	

"CABARET" COIL CHART

NOTICE:

THIS GAME OPERATES ON 24 VOLTS. WHEN ORDERING REPLACEMENT TRANSFORMERS, MOTORS, COILS OR METERS ... MAKE SURE TO SPECIFY CORRECT PART NUMBERS.

NUMBER	DESCRIPTION	LOCATION
14 A 7805	SCORE MOTOR - 60 CYCLE	MECH. PANEL
14 A 7806	SCORE MOTOR - 50 CYCLE	MECH. PANEL
15 A 6771	TRANSFORMER - 60 CYCLE	MECH. PANEL
15 A 6773	TRANSFORMER - 50 CYCLE	MECH. PANEL
B 6396	24 VOLT METER (COIL #XM 27-675)	MECH. PANEL
<u>SOLENOID COILS</u>		
A 22-550	BALL RELEASE COIL PLAYER UNIT STEP UP MATCH UNIT STEP UP COIN UNIT STEP UP	PLAYFIELD INSERT INSERT MECH. PANEL
A 23-600	BALL COUNT UNIT STEP UP REPLAY UNIT STEP UP	MECH. PANEL INSERT
A2-23-750	LARGE BELL KNOCKER	CABINET CABINET
B 26-800	COIN UNIT RESET REPLAY UNIT RESET PLAYER UNIT RESET BALL COUNT UNIT RESET SCORE DRUM UNIT ... ( 16 req'd.) BONUS DRUM UNIT ADVANCE UNIT	MECH. PANEL INSERT INSERT MECH. PANEL INSERT INSERT PLAYFIELD
FL 21-375/ 28-400	FLIPPER COILS ... (2 req'd.)	PLAYFIELD
G 22-550	JET BUMPER COILS ... (5 req'd.)	PLAYFIELD
G 23-750	KICKER COILS ... (2 req'd.) EJECT COIL DISAPPEARING POST (LATCH)	PLAYFIELD PLAYFIELD PLAYFIELD
<u>RELAY COILS</u>		
M 29-1000	GAME OVER RELAY (TRIP) 1st & 2nd RESET RELAY 3rd & 4th RESET RELAY DISAPPEARING POST (TRIP)	MECH. PANEL INSERT INSERT PLAYFIELD
M 29-1100	1 PT. RELAY 10 PT. RELAY 100 PT. RELAY EJECT RELAY NO. 1 BUMPER RELAY NO. 2 BUMPER RELAY NO. 3 BUMPER RELAY 10 ¢ RELAY 25 ¢ RELAY 300 RELAY ADVANCE RELAY	INSERT INSERT INSERT PLAYFIELD PLAYFIELD PLAYFIELD PLAYFIELD MECH. PANEL MECH. PANEL PLAYFIELD PLAYFIELD
M 30-1400	YELLOW RELAY WHITE RELAY GREEN RELAY RED RELAY	PLAYFIELD PLAYFIELD PLAYFIELD PLAYFIELD
Z 27-1000	REPLAY RELAY COIN RELAY RESET RELAY OUTHOLE RELAY PLAYER RESET RELAY GAME OVER RELAY (LATCH) BONUS RESET RELAY	MECH. PANEL MECH. PANEL MECH. PANEL MECH. PANEL MECH. PANEL MECH. PANEL MECH. PANEL
Z 28-1150	LOCK RELAY EXTRA BALL TILT RELAY	MECH. PANEL MECH. PANEL MECH. PANEL
Z 28-1200	BALL INDEX RELAY	MECH. PANEL
M1-31-1500	COIN LOCKOUT	DOOR

# ADJUSTMENTS IN BACKBOX

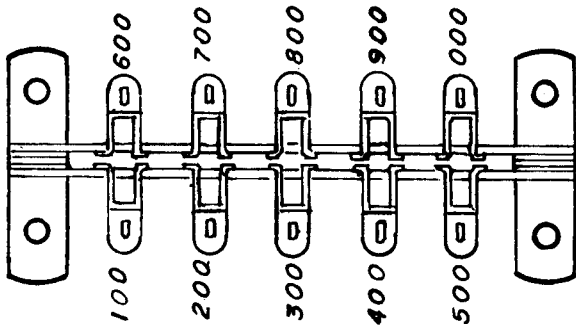

## HI-Score Adjustment

Insert plugs into 10 Point Female at desired positions.

Examples:

Yellow wire into 300 position scores at 3300.

Yellow wire into 000 position scores at 4000.

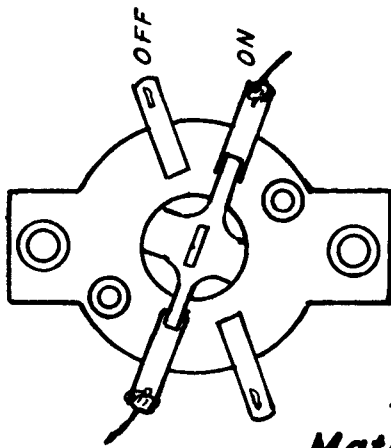
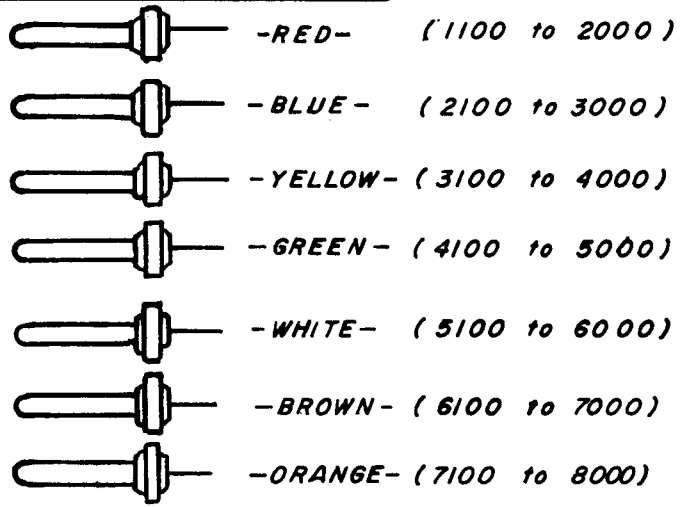

## Number Match Adjustment

In 'ON' position, a number match lite will appear when game is over. To award replays, when number is matched, Extra Ball Adjustment Jack must be in 'Replay' position. In 'Off' position, Number Match is inoperative.

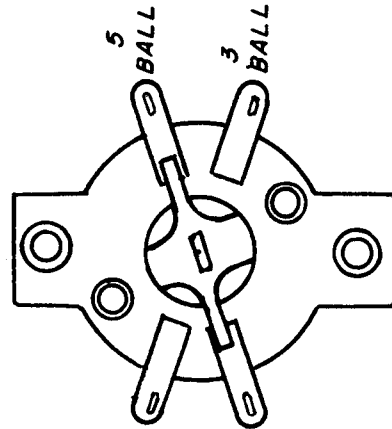

## No. of Balls Adjustment

This switch changes 3 Ball to 5 Ball play, or vice versa.

## SUPER BONUS ADJ.

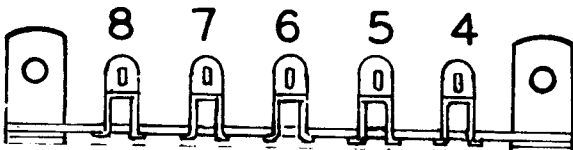

AWARDS "SPECIAL" FOR SCORE ON SUPER BONUS DRUM.



# ADJUSTMENTS ON MECHANISM PANEL

## 10¢ Adjustment

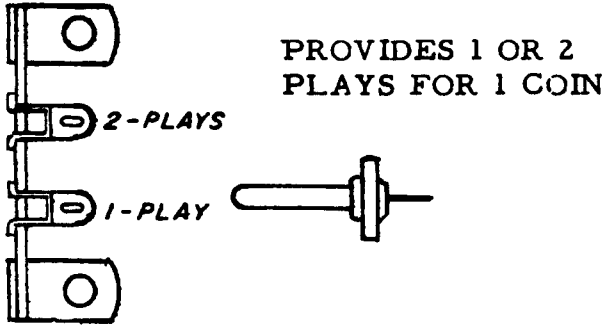

## Motor Service Jack

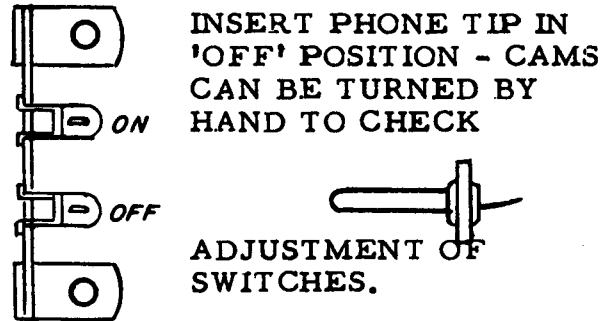

## 25¢ Adjustment

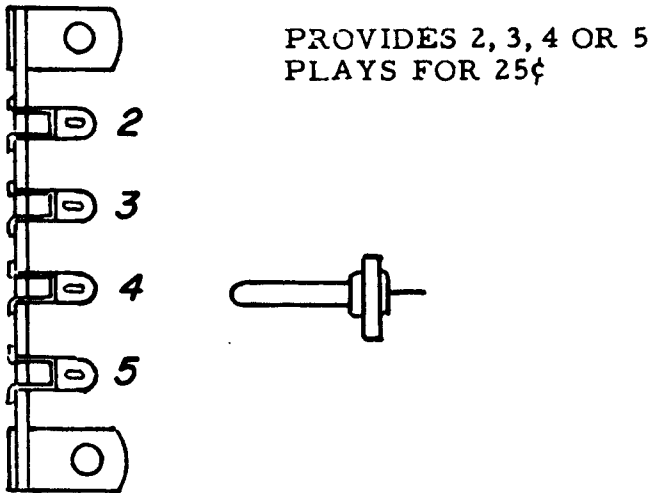

## MASTER ON-OFF SW.

(Located under front of Cabinet)

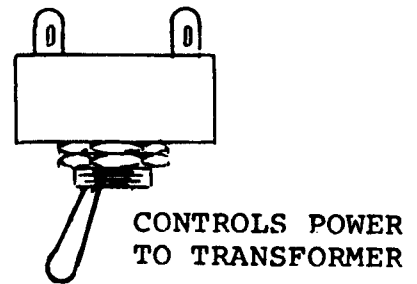

## REPLAY-EXTRA BALL-1000 ADJ.

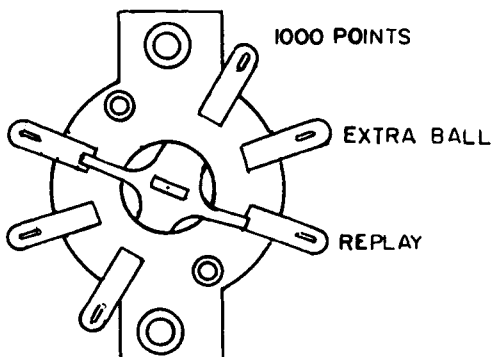

IN 1000 POSITION:  
SUPER BONUS "SPECIAL" SCORES  
1000 POINTS.

IN EXTRA BALL POSITION:  
SUPER BONUS AND HI-SCORE  
"SPECIALS" AWARD EXTRA BALL.

IN REPLAY POSITION:  
SUPER BONUS, HI-SCORE AND  
NUMBER MATCH WILL REGISTER A  
REPLAY.

# " CABARET " - POST ADJUSTMENT SHEET

TO MAKE GAME MORE " CONSERVATIVE " OR " LIBERAL " - MOVE POSTS 3/16" AS SHOWN IN SKETCH BELOW. SPOTTING HOLES ARE PROVIDED AND CAN BE SEEN ON REMOVAL OF POSTS.

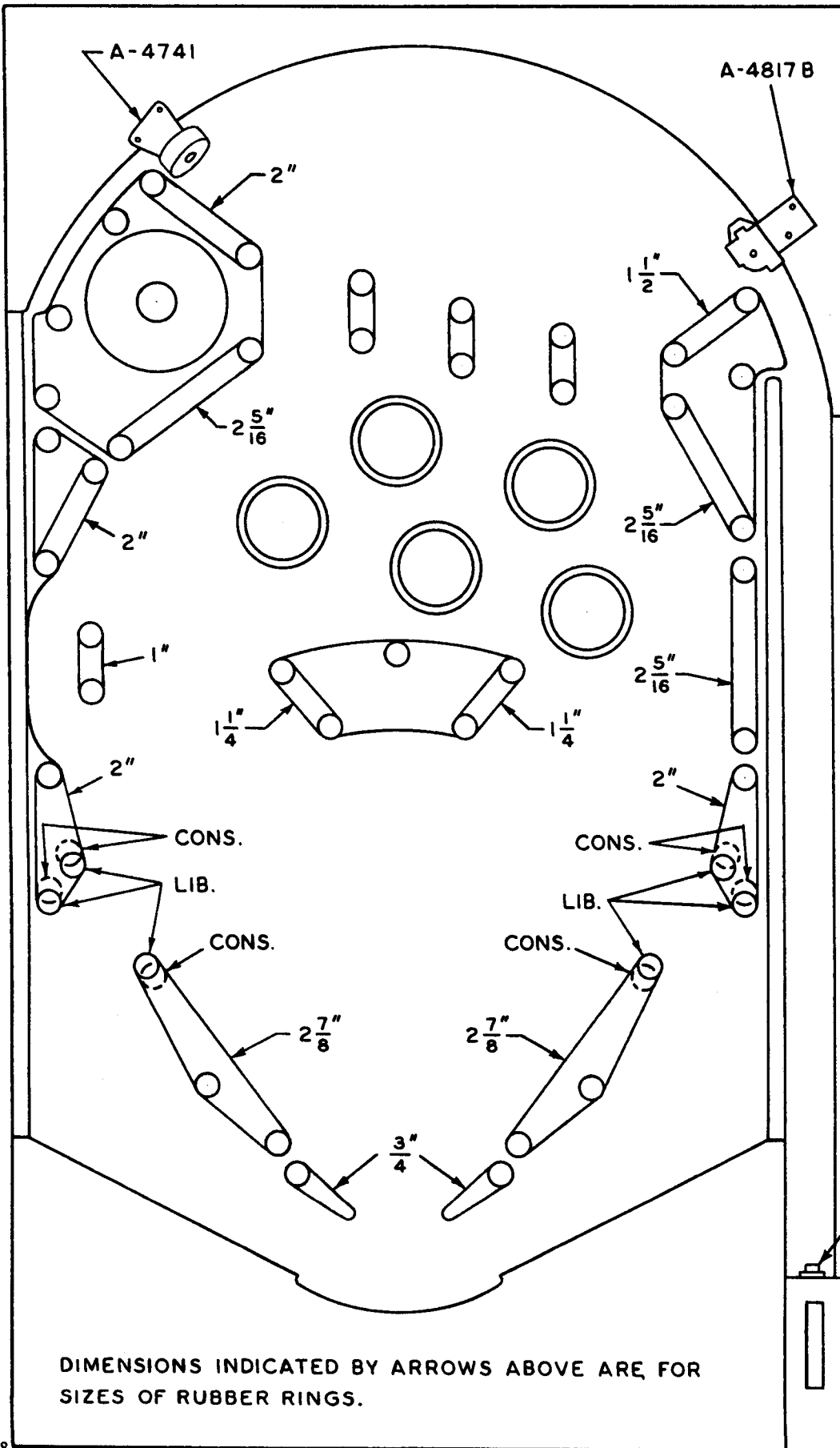

## ABBREVIATIONS :

CONS.-CONSERVATIVE  
LIB.-LIBERAL

## RUBBER RING NUMBERS :

23A-6300	5/16" I.D.
23A-6301	3/4" I.D.
23A-6303	1 1/4" I.D.
23A-6304	1 1/2" I.D.
23A-6305	2" I.D.
23A-6306	2 5/16" I.D.
23A-6307	2 7/8" I.D.
23A-6302	1" I.D.

A-4741 REBOUND ASS'Y.  
A-4817B-BALL GATE ASS'Y.

23A-6327 BALL SHOOTER  
RUBBER TIP

DIMENSIONS INDICATED BY ARROWS ABOVE ARE FOR SIZES OF RUBBER RINGS.

## CABARET OPERATES AS FOLLOWS:

THE ADVANCE UNIT, SHOWN AS THE "SCORE SELECTOR" ON PLAYFIELD, ADVANCES ONE STEP EACH TIME A "CHANGE" SWITCH IS MADE. IT CONTROLS THE SCORING VALUES OF THE JET BUMPERS AND ROLLOVERS BY ENERGIZING THE GREEN, YELLOW, WHITE OR RED RELAYS. FOR EXAMPLE: WHEN THE GREEN COLOR IS LIT ON THE "SCORE SELECTOR", THE GREEN RELAY IS ENERGIZED AND CHANGES THE VALUE OF TOP RIGHT ROLLOVER FROM 10 TO 100, THE (2) GREEN JET BUMPERS FROM 1 to 10 AND THE BOTTOM RIGHT (INSIDE) ROLLOVER FROM 100 to 300.

WHEN THE RED COLOR IS LIT ON "SCORE SELECTOR", THE RED RELAY IS ENERGIZED WHICH IN TURN ENERGIZES THE GREEN, YELLOW AND WHITE RELAYS. ALL ROLLOVERS AND JET BUMPERS WILL LITE FOR THE HIGHER INDICATED VALUES. ALSO, THE LEFT SIDE ROLLOVER WILL LITE FOR EXTRA BALL.

THE CENTER EJECT HOLE SCORES 300 POINTS AND ADVANCES THE SUPER BONUS DRUM ONE STEP. ADVANCING THE SUPER BONUS DRUM TO INDICATED SCORE ON CARD WILL REGISTER A "SPECIAL".

THE DISAPPEARING POST, LOCATED BETWEEN THE FLIPPERS, IS CONTROLLED BY THE NUMBER MATCH DISC, THRU A SWITCH ON THE 1 POINT RELAY.

### POWER TRANSFORMER:

LOCATED ON MECHANISM PANEL. IT IS EQUIPPED WITH A SECONDARY TAP. IF YOUR GAME IS ON LOCATION WITH EXTREMELY LOW LINE VOLTAGE, REMOVE LEAD FROM LUG MARKED 24 VOLTS AND SOLDER TO ALTERNATE LUG MARKED "HIGH". THIS WILL BOOST SECONDARY VOLTAGE APPROXIMATELY 2-3 VOLTS.

### LEG LEVELERS:

ARE PROVIDED FOR TWO PURPOSES - 1st TO LEVEL GAME ON LOCATION, 2nd TO INCREASE PITCH FOR GAME PERCENTAGING. IF IT IS DESIRED TO SPEED UP PLAY AND DECREASE SCORES, RAISE REAR LEG LEVELERS TO INCREASE PITCH.

### SUGGESTED SCORE CARDS:

FOR 5 BALL PLAY - 359-2 & 359-55

FOR 3 BALL PLAY - 359-2A & 359-54A

## 1. GENERAL

NEVER EXPERIMENT with any of the mechanism. Locate any trouble with the aid of Wiring Diagrams or Operating & Servicing Information supplied with the machine, then check for proper adjustment of the units involved before making any changes. Improper adjustment or make-shift repair will only cause serious damage to other parts of the machine or repeated failure of the part.

NOTE: Always look for a possible loose wire, bad connection at a plug and socket, broken or unhooked springs on step-up units, relays, etc., before adjustments are made or wires reconnected.

## 2. FUSES

IMPORTANT: Never replace fuses with any rating other than specified on the fuse block; this block is located adjacent to the transformer.

## 3. LUBRICATION

Over-lubrication causes far more trouble in coin operated equipment than under-lubrication. Practically all cases of poor contact on switches and wiper discs are due to oil or grease, or oil vapor, which forms a film or residue on the contacts and will not allow current to pass through. Excess lubricant may also seep into clutches causing them to slip.

IMPORTANT: NEVER USE VASELINE FOR LUBRICATION OF ANY PART OF THE MACHINE. Vaseline is not a true lubricant. It leaves a dirty and gummy residue and it becomes very thick when cold. A special Coin Machine Lubricant is supplied with each machine.

STEP-UP Levers, Ratchets, Cams, Shafts and other sliding or oscillating parts should be very lightly greased with special Coin Machine Lubricant (supplied with machine) not oftener than every six months. The bakelite discs (biscuits) on the Motor Units and Step-up Units will require lubrication with the special Coin Machine Lubricant only after the grease is completely evaporated (3 to 12 months, depending on climate) or when the film of grease becomes dirty. In either event, clean the parts thoroughly with a solvent, then apply an extremely thin coat of the special grease.

Solenoid Plungers should not have a lubricant of any kind. Should there be a sluggish tendency or if plungers are sticking, the parts should be cleaned with a solvent and flaked graphite applied on reassembly.

## 4. RELAY and SWITCH ADJUSTMENT

Where relay adjustments are called for, before bending blades, in all cases, on any machine, make certain that the screws holding the switch stacks are down very tightly. This is suggested because the plastic spacers in the switch stacks have occasionally shrunk by drying out, causing a poor adjustment.

## WHAT TO DO IF:

1. Lights are out, game is inoperative:
  - a. Check A.C. cord and plugs for breaks, cuts or other damage.
  - b. Check fuses, located behind cash box.
  - c. Check master switch, located under front of cabinet.
  - d. Check plugs and jacks for proper installation.
2. Lights are out, game operates:
  - a. Check two switches on Lock Relay: Blue-Yellow-White to Green-Yellow-White, and Brown-Yellow-White to Green-Yellow-White.
  - b. Check 10 AMP fuse-Blue wire, and 15 AMP fuse-Brown wire.
3. Lights are on, but all coins are rejected:
  - a. If Coin Lockout Coil (located on front door) is not energized, check the Last Position Break Switch on Replay Unit: Black and Black-Red. Check switch on Index Cam; Green-Red and Yellow. Check switch on Reset Relay; Green-Red and White-Gray.
  - b. If Coin Lockout Coil is energized, check the wire forms actuated by the armature on this coil. Then check the slug rejector.
4. Game resets but Game Over Relay trips immediately:
  - a. Check switch on Lock Relay Blu-Red and Yellow.
  - b. Check Ball Count Unit Reset Coil.
  - c. Check Ball Count Unit wiper fingers for proper resetting.
5. Game is over, replays are indicated, but the Replay Button fails to start a new game:
  - a. Check Make and Break Switch on Index Cam (Green-Red and Yellow).
  - b. Check switch on Reset Relay (Green-Red and White-Gray).
  - c. Check Reply Button Switch.
  - d. Check Replay Unit Zero Switch, White-Orange and White-Brown.
  - e. Check switch on Game Over Relay (White-Brown and White-Blue).
  - f. Check Replay Relay Coil.
6. Super Bonus Drum does not reset to zero when ball leaves playfield:
  - a. Sequence of operation - - - Outhole Switch energizes Outhole Relay.  
Switch "C" of Outhole Relay energizes Bonus Reset Relay.  
Bonus Reset Relay is held in thru Zero Position Switch on Bonus Drum Unit.  
Switch "B" on Bonus Reset Relay continues to run Score Motor.  
Switch "C" on Bonus Reset Relay pulses Bonus Drum Unit, thru Impulse Cam Switch "B" and zero position Switch on Bonus Drum Unit (Black-Red and Red-Blu).
7. Disappearing Post does not function properly:
  - a. Latch and Trip coils are controlled by Number Match Unit Disc, and Switch on 1 Point Relay.
  - b. For Latch Coil, check Red-Green to Red-Blu on Number Match Disc.
  - c. For Trip Coil, check Red-Yellow to Red-Blu on Number Match Disc.
  - d. Check switch on 1 Point Relay, Yellow and Red-Blu.

# SUGGESTED TIPS FOR PEAK COLLECTIONS

## 1. CLEAN, NEAT EQUIPMENT:

- a. Playfields — clean semi-monthly or sooner if necessary.
- b. Cabinet — same as above.
- c. Glass — ask location to cooperate, clean daily.

## 2. PROPER WORKING EQUIPMENT:

- a. Replace lite bulbs if blown.
- b. Bring game into shop for periodical adjustment and thorough check-up.
- c. Rubbers — clean or replace often, keeps playfield live.

## 3. ROTATE GAMES:

- a. Cash box should indicate time for change, however eight weeks is the usual peak player interest.

Remember: to keep player interest high - **Rotate, Rotate Rotate**. Playing games is a habit. Don't let your players lose it.

## 4. SERVICE:

This is your business; carry a good supply of replacement parts such as:

- |              |                              |
|--------------|------------------------------|
| a. fuses     | e. Springs                   |
| b. coils     | f. Contact blades & tips     |
| c. Rubbers   | g. Step-up or actuating arms |
| d. Litebulbs | h. Proper Tools              |

**Games Out-of-order cannot earn money.**

# SCORE DRUM UNIT

WITH PRINTED CIRCUIT AND CONTACT RING

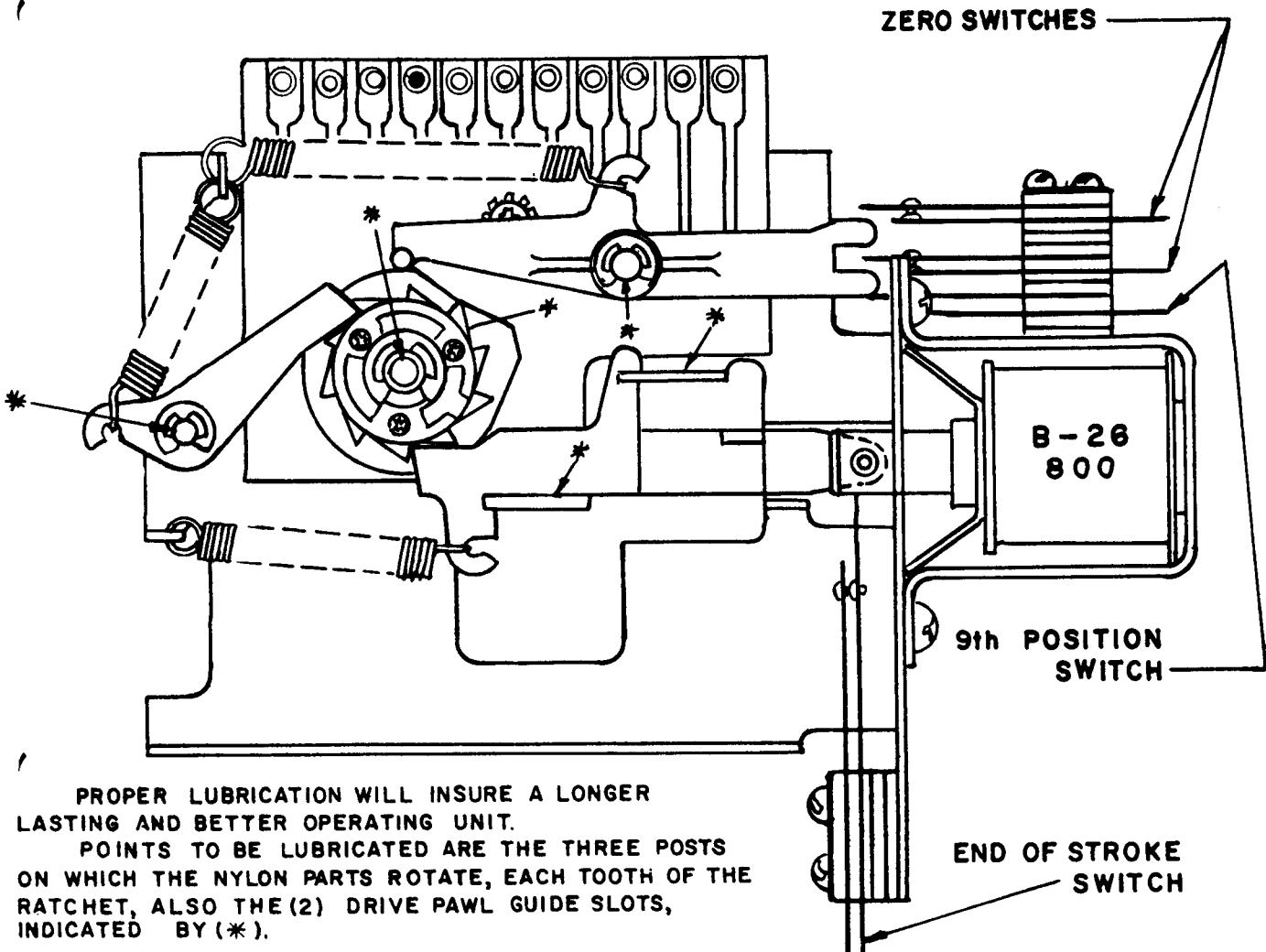

PROPER LUBRICATION WILL INSURE A LONGER LASTING AND BETTER OPERATING UNIT.

POINTS TO BE LUBRICATED ARE THE THREE POSTS ON WHICH THE NYLON PARTS ROTATE, EACH TOOTH OF THE RATCHET, ALSO THE (2) DRIVE PAWL GUIDE SLOTS, INDICATED BY (\*).

**LUBRICATION: DO NOT PUT LUBRICANT ON DRIVE ARMATURE**

## SWITCH ADJUSTMENT

AT "0" OR INDEX POSITION ALL SWITCHES ARE OPEN AS SHOWN.

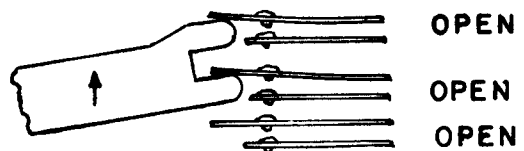

AT 1st. TO 8th. POSITION TOP SWITCHES ARE CLOSED—BOTTOM SWITCH REMAINS OPEN.

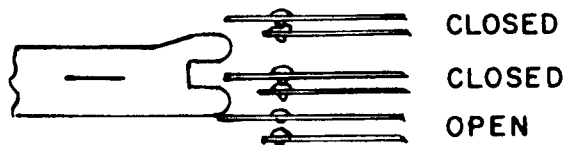

AT 9th POSITION ALL SWITCHES ARE CLOSED AS SHOWN

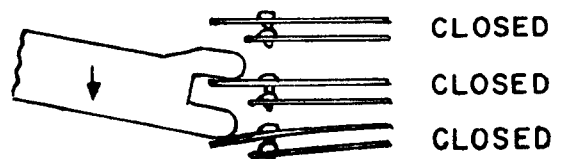

IN CIRCUIT TO BALL COUNT S.U. AFTER LAST PLAYER COMPLETES HIS TURN.  
TO 1000 POINT DRUM UNIT COILS, THRU BONUS UNIT DISC

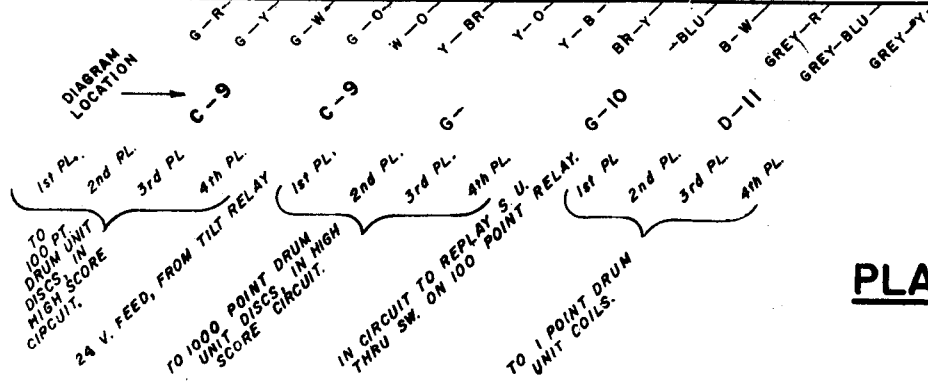
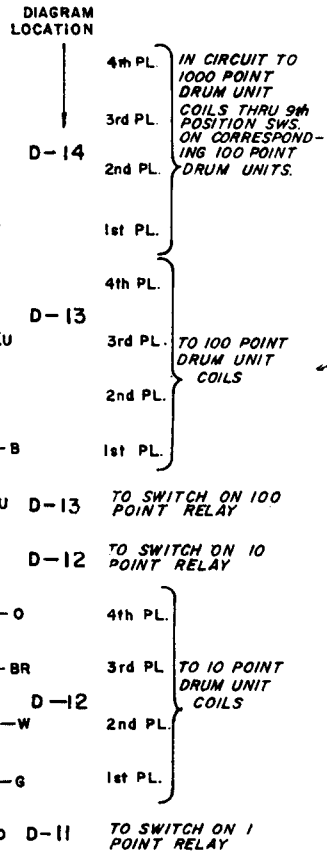
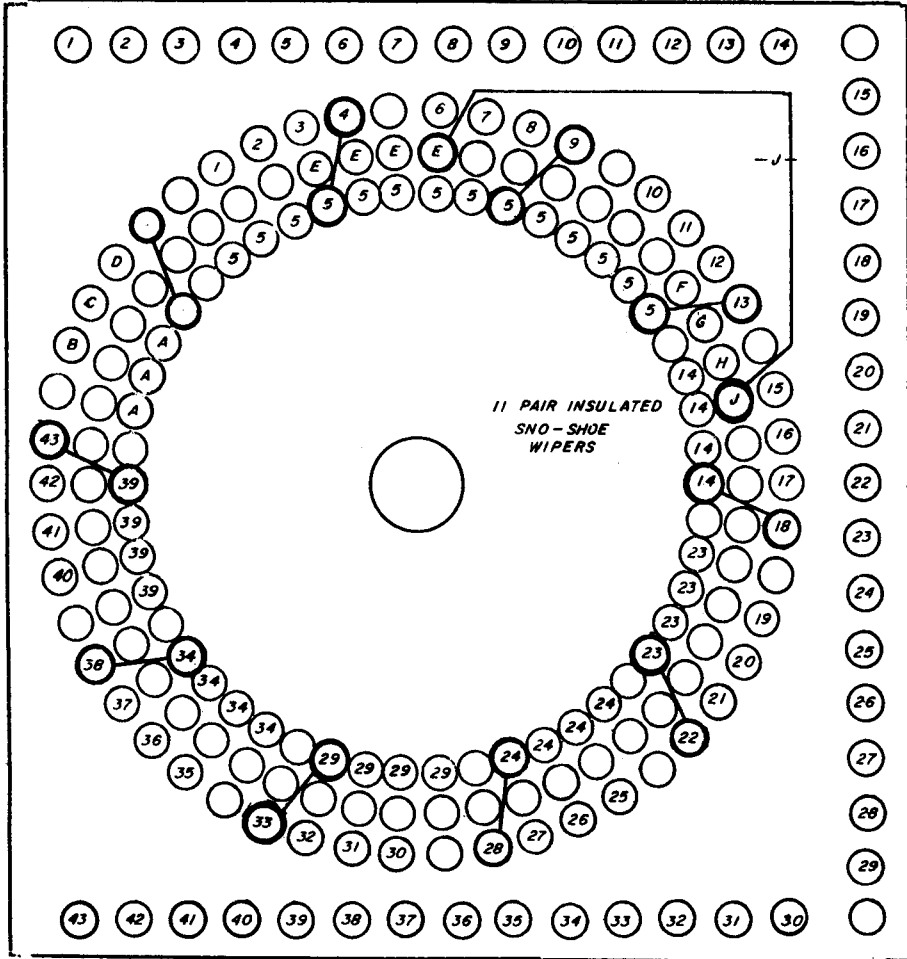
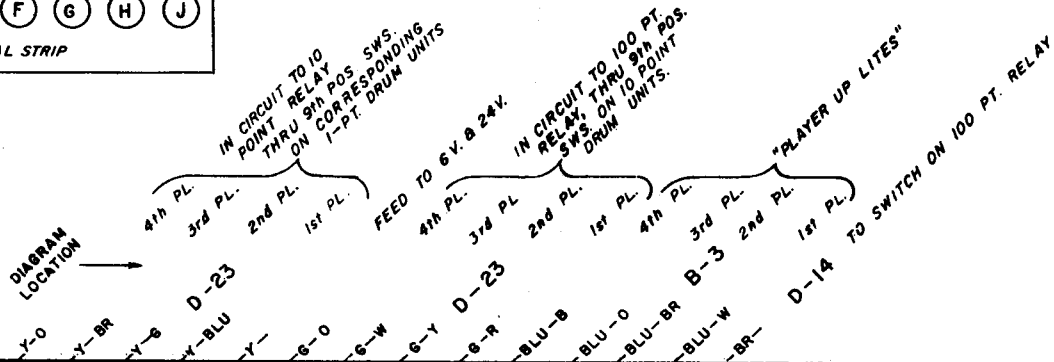
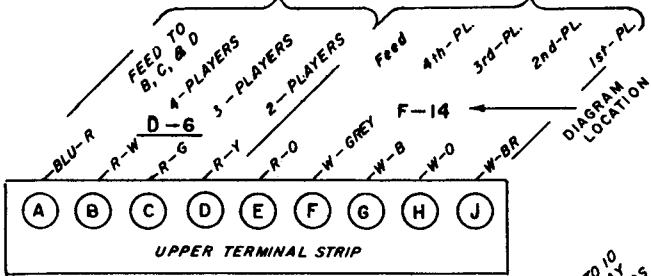

View looking at WIPER FINGER side with unit in RESET position (1st Player Up)

# PLAYER UNIT DISC



# No. MATCH UNIT

THIS UNIT ADVANCES ONE STEP EACH TIME THE ONE POINT RELAY IS PULSED.

View looking at  
WIPER FINGER side

IN No. MATCH CIRCUIT.  
THESE WIRES COME FROM  
THE 1-PT. D.U. DISC OF  
ALL FOUR PLAYERS.

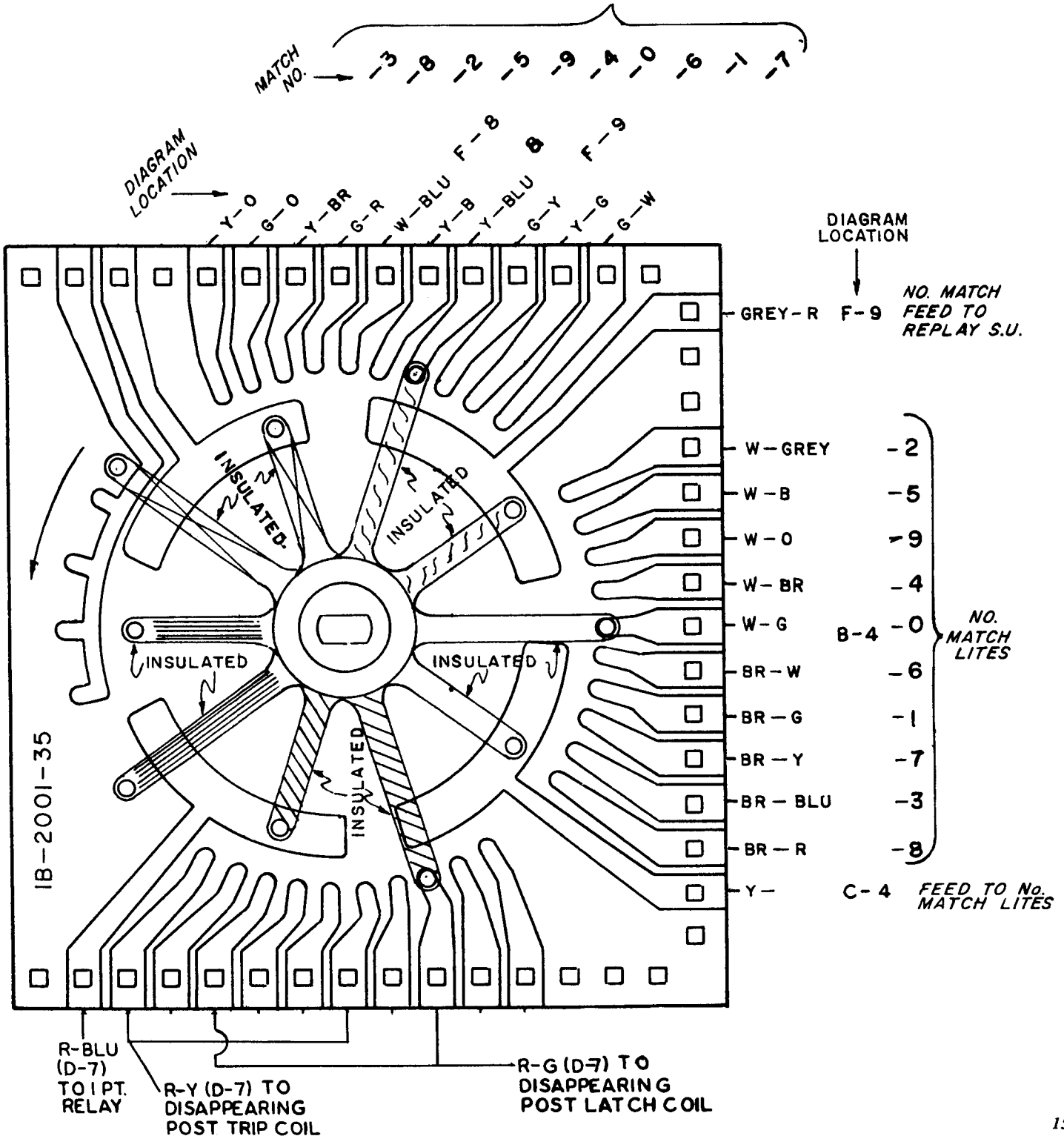

# BALL COUNT UNIT DISC

THIS UNIT RESET AT THE START OF A NEW GAME, (DURING RESET CYCLE). IT ADVANCES ONE STEP EACH TIME THE LAST PLAYER COMPLETES HIS TURN.

View looking at WIPER FINGER side  
with WIPER in ZERO position.

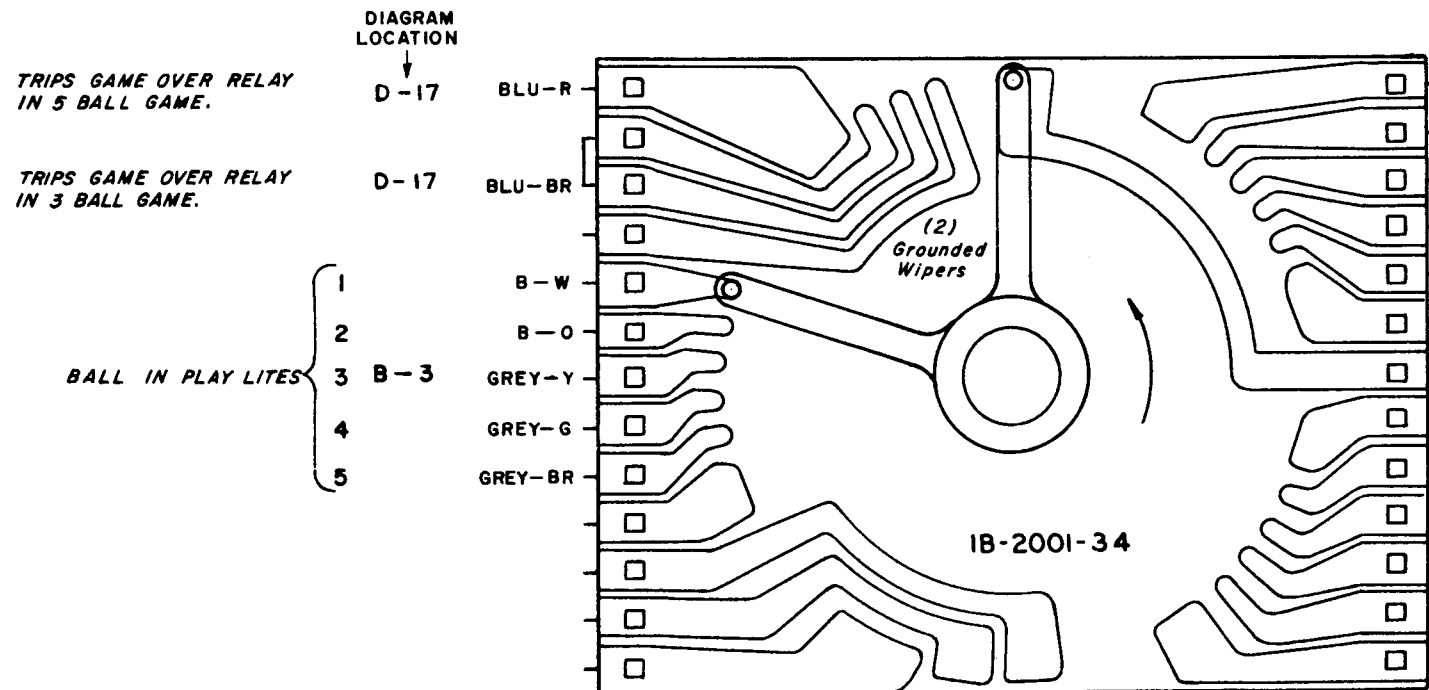

# COIN S. U. DISC

THIS UNIT RESET AT START OF A GAME ( DURING RESET CYCLE). IT THEN ADVANCES ONE STEP EACH TIME THE COIN RELAY IS PULSED.

*View looking at WIPER FINGER side with WIPER in RESET position*

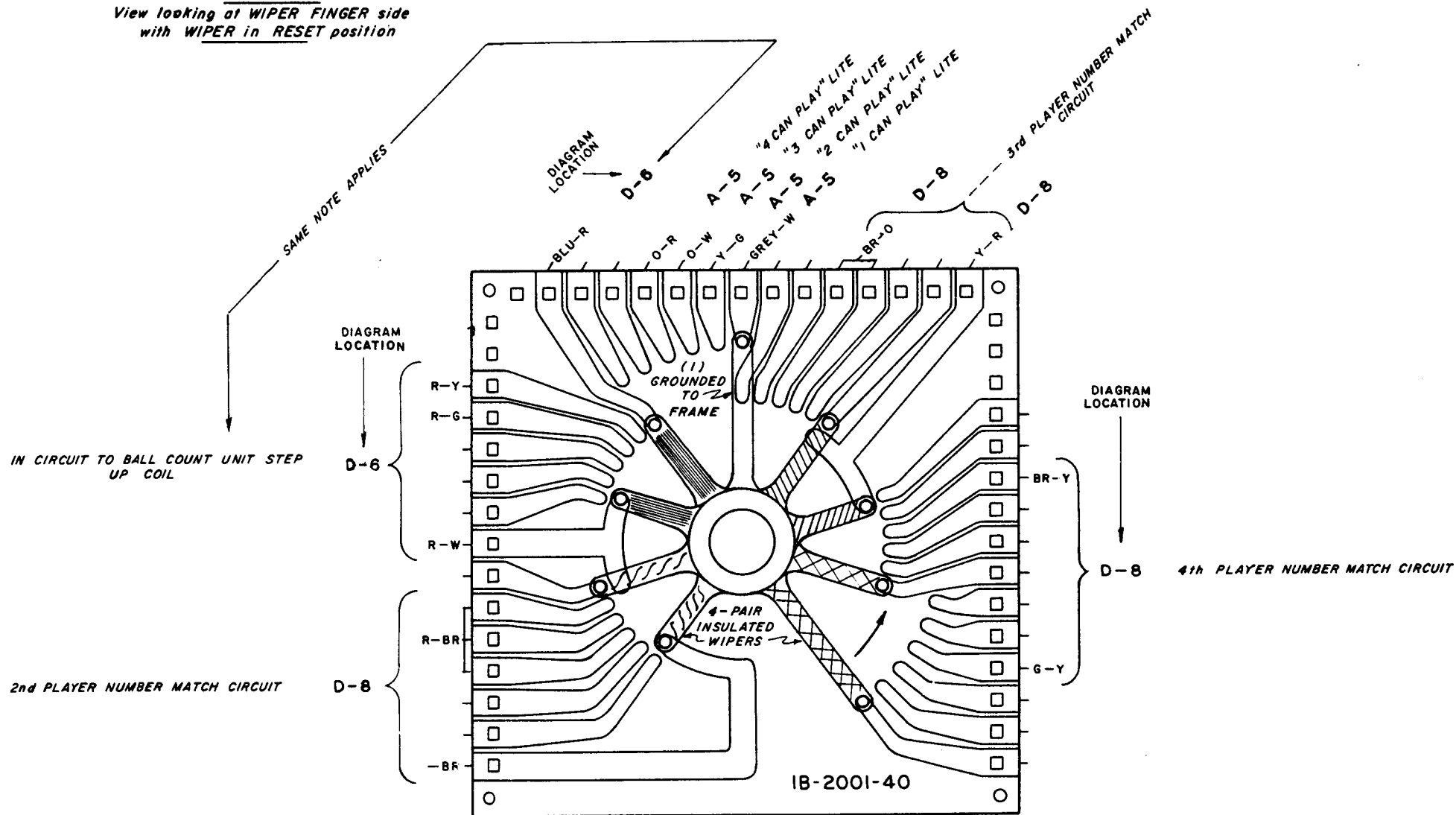

# A.C. RELAYS & SWITCHES

(ON MECHANISM PANEL)

## GAME OVER RELAY (INTERLOCK)

LATCH COIL IS PULSED BY SCORE MOTOR CAM SWITCH 1B, THRU SWITCHES ON COIN RELAY AND RESET RELAY. TRIP COIL IS PULSED BY WIPER FINGER ON BALL COUNT UNIT. ALSO BY SWITCH "D" ON LOCK RELAY.

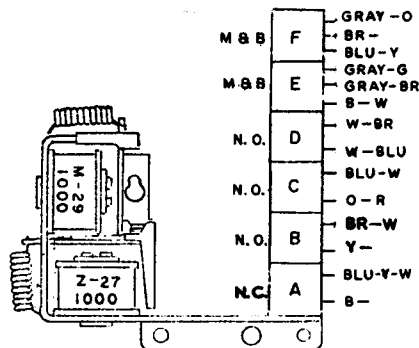

DIAGRAM LOCATION

A-3

F-8

F-3

D-6

C-7

G-16

## OPERATION

TO PLAYER UP LITES--ALSO TO GAME-OVER AND NO. MATCH LIFES.

OPENS HIGH SCORE CIRCUIT AND MAKES IN NO. MATCH CIRCUIT.

TO REPLAY RELAY, THRU REPLAY BUTTON SWITCH.

ENERGIZES RESET RELAY, THRU SWITCH "C" ON COIN RELAY.

ENERGIZES DISAPPEARING POST (LATCH COIL).

OPENS CIRCUITS TO ALL PLAYFIELD SWITCHES.

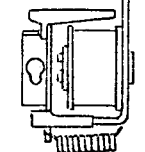
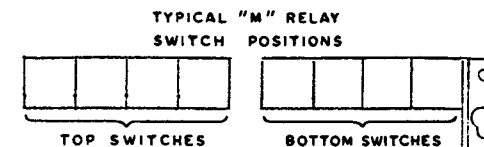

## 10¢ RELAY

IS ENERGIZED BY 10¢ COIN SWITCH, IF 10¢ ADJUSTMENT JACK IS IN "2 PLAYS" POSITION.

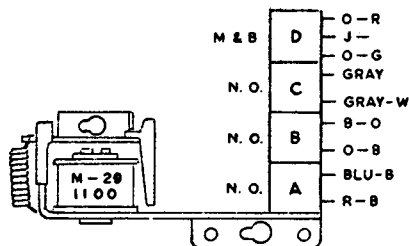

D-5

D-8

E-16

E-2

IN CIRCUIT TO KNOCKER COIL--ALSO RUNS SCORE MOTOR.

PULSES REPLAY S.U. THRU IMPULSE CAM SWITCH "B".

ENERGIZES LOCK RELAY.

IN HOLD CIRCUIT TO THIS RELAY.

## 25¢ RELAY

IS ENERGIZED BY 25¢ COIN SWITCH.

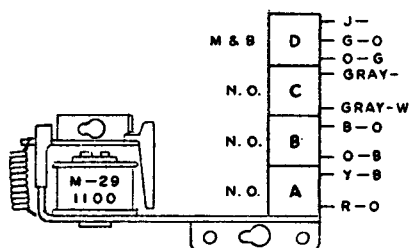

C-5

D-8

E-16

E-2

IN CIRCUIT TO KNOCKER COIL---ALSO RUNS SCORE MOTOR.

PULSES REPLAY S.U. THRU IMPULSE CAM SWITCH "B".

ENERGIZES LOCK RELAY.

IN HOLD CIRCUIT TO THIS RELAY.

## BALL INDEX RELAY

IS ENERGIZED BY SWITCH "D" ON TILT RELAY. IT IS ALSO ENERGIZED BY 10 POINT OR 100 POINT RELAY, THRU SWITCH "D" ON EXTRA BALL RELAY.

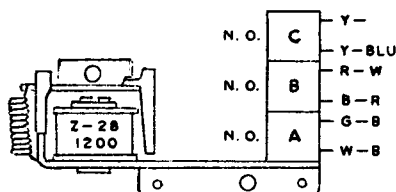

C-18

D-7

E-18

PROVIDES A HOLD CIRCUIT TO EXTRA BALL RELAY WHILE BALL IS ON PLAYFIELD.

IN CIRCUIT TO PLAYER UP UNIT STEP-UP AND RESET COILS.

IN HOLD CIRCUIT TO THIS RELAY.

# A.C. RELAYS & SWITCHES

(ON MECHANISM PANEL)

## OUTHOLE RELAY

IS ENERGIZED BY OUTHOLE SWITCH, THRU SCORE MOTOR INDEX CAM SWITCH "C".

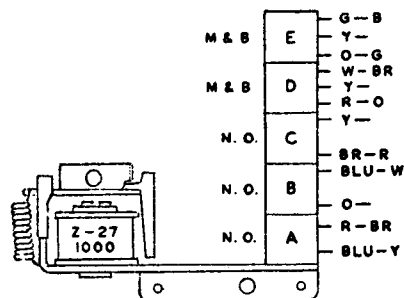

DIAGRAM LOCATION

C-18  
&  
E-5  
C-17  
&  
C-7  
  
C-15  
  
E-18  
  
F-16

## OPERATION

IN SERIES WITH SWITCH "A" ON BALL INDEX RELAY--ALSO RUNS SCORE MOTOR.

HOLD CIRCUIT TO TILT RELAY OR---IN SERIES WITH SWITCH "B" ON BALL INDEX RELAY.

ENERGIZES BONUS RESET RELAY.

ENERGIZES BALL RELEASE COIL THRU SCORE MOTOR CAM SWITCH 3A.

IN HOLD CIRCUIT TO THIS RELAY.

## TILT RELAY

IS ENERGIZED BY TILT SWITCHES.

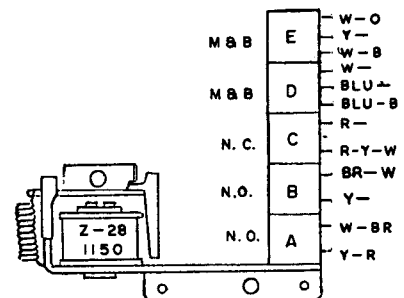

C-9  
&  
E-18  
  
A-6  
  
G-18  
  
C-7  
  
E-17

IN HIGH-SCORE CIRCUIT TO REPLAY S.U. COIL. ALSO ENERGIZES BALL INDEX RELAY.

OPENS CIRCUIT TO PLAYFIELD LITES AND MAKES TO "TILT" LITE.

BREAKS POWER TO ALL PLAYFIELD SWITCHES EXCEPT EJECT AND OUTHOLD SWITCH.

ENERGIZES DISAPPEARING POST (LATCH COIL).

IN HOLD CIRCUIT TO THIS RELAY.

## EXTRA BALL RELAY

IS ENERGIZED BY LEFT SIDE ROLLOVER SWITCH, THRU SWITCH "A" ON RED RELAY. IT ALSO IS ENERGIZED BY HI-SCORE AND BONUS DRUM SCORE CIRCUITS, IF "REPLAY-EXTRA BALL" ADJUSTMENT JACK IS IN EXTRA BALL POSITION.

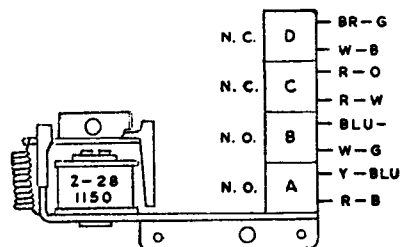

E-18  
  
D-7  
  
A-6  
  
F-18

INSURES THAT EXTRA BALL RELAY DROPS OUT BEFORE BALL INDEX RELAY PULLS IN.

IN SERIES WITH SWITCH "B" ON BALL INDEX RELAY.

TO "SHOOT AGAIN" LITES.

IN HOLD CIRCUIT TO THIS RELAY.

## REPLAY RELAY

IS ENERGIZED BY REPLAY BUTTON, WHEN ONE OR MORE CREDITS ARE AVAILABLE ON REPLAY UNIT.

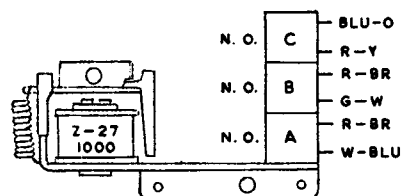

F-6  
  
D-3  
  
D-3

PULSES REPLAY UNIT RESET COIL, THRU CAM SWITCH 1B.

ENERGIZES COIN RELAY.

IN HOLD CIRCUIT TO THIS RELAY.

## A.C. RELAYS & SWITCHES (ON MECHANISM PANEL)

### LOCK RELAY

IS ENERGIZED BY 10¢, 25¢ OR COIN RELAYS. ALSO BY LEFT FLIPPER BUTTON SWITCH.

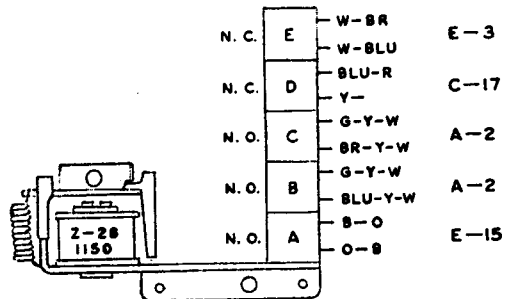

DIAGRAM  
LOCATION

### OPERATION

IN CIRCUIT TO REPLAY RELAY, THRU REPLAY BUTTON SWITCH.  
ENERGIZES GAME-OVER RELAY (TRIP COIL).  
6 VOLTS TO LIFES, FROM TRANSFORMER.  
6 VOLTS TO LIFES, FROM TRANSFORMER.  
IN HOLD CIRCUIT TO THIS RELAY, THRU KICK-OFF SWITCH.

### BONUS RESET RELAY

IS ENERGIZED BY SWITCH "D" ON COIN RELAY OR SWITCH "C" ON OUTHOLE RELAY.

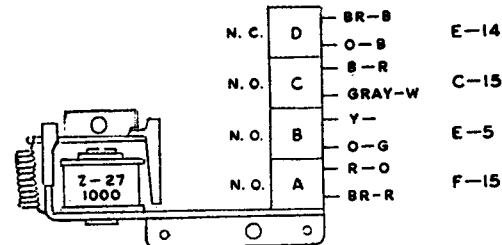

IN CIRCUIT TO REPLAY S.U., THRU BONUS DRUM DISC.  
PULSES BONUS DRUM UNIT THRU IMPULSE CAM SWITCH B.  
RUNS SCORE MOTOR.  
HOLD CIRCUIT TO THIS RELAY, THRU BONUS DRUM UNIT ZERO POSITION SWITCH.

### PLAYER RESET RELAY

IS ENERGIZED BY BALL COUNT UNIT END-OF-STROKE SWITCH.

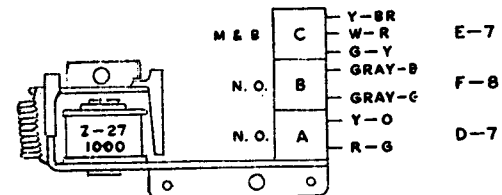

IN SERIES WITH SWITCH B ON BALL INDEX RELAY.  
IN NO. MATCH CIRCUIT THRU SWITCH "D" ON GAME-OVER RELAY.  
HOLD CIRCUIT TO THIS RELAY, THRU INDEX CAM SWITCH "B".

### RESET RELAY

IS ENERGIZED BY SWITCH "C" ON COIN RELAY, WHEN GAME OVER RELAY IS IN TRIPPED POSITION.

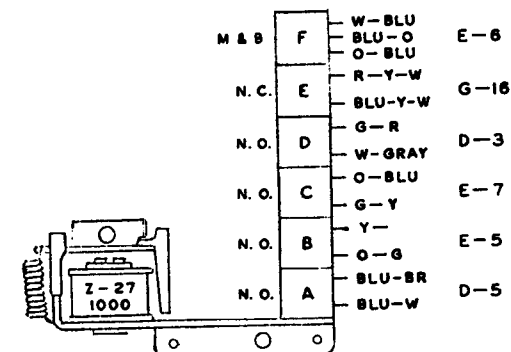

ENERGIZES RESET COILS ON BALL COUNT AND COIN UNITS, THRU SWITCH ON COIN RELAY.  
IN SERIES WITH SWITCH "A" ON GAME-OVER RELAY.  
DOES NOT ALLOW REPLAY RELAY TO ENERGIZE AGAIN, AFTER IT HAS DROPPED OUT (DURING RESET CYCLE).  
IN CIRCUIT TO PLAYER UNIT RESET COIL.  
RUNS SCORE MOTOR.  
IN HOLD CIRCUIT TO THIS RELAY, THRU (16) DRUM UNIT ZERO POSITION BREAK SWITCHES.

# A.C. RELAYS & SWITCHES

(ON MECHANISM PANEL)

## COIN RELAY

IS ENERGIZED BY COIN SWITCH OR BY REPLAY RELAY.

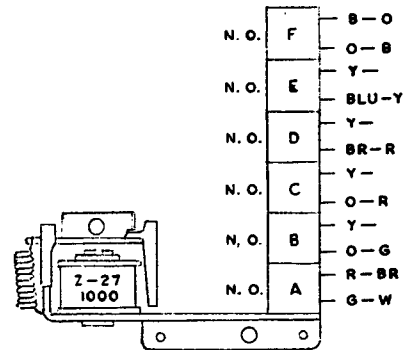

DIAGRAM LOCATION

E-16

C-17

C-15

C-6

E-5

D-3

## OPERATION

ENERGIZES LOCK RELAY.

ENERGIZES GAME-OVER RELAY (TRIP COIL), THRU PLAYER UNIT OR BALL COUNT UNIT ZERO SWITCHES.

ENERGIZES BONUS RESET RELAY.

ENERGIZES RESET RELAY, THRU SWITCH "B" ON GAME-OVER RELAY.

RUNS SCORE MOTOR.

IN HOLD CIRCUIT TO THIS RELAY.

(LOCATED ON PLAYFIELD)

## WHITE RELAY

IS ENERGIZED BY WIPER FINGER ON ADVANCE UNIT DISC. ALSO BY SWITCH "E" ON RED RELAY.

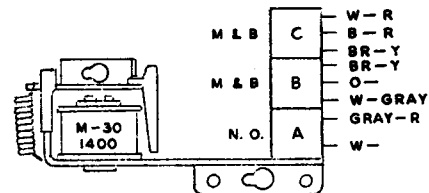

E-21

E-20

A-8

TO 10 POINT OR 100 POINT RELAY, THRU SWITCH "B" ON NO.3 BUMPER RELAY.

TO 100 POINT OR 300 POINT RELAY, THRU TOP ROLLOVER SWITCH (WHITE).

TO CENTER JET BUMPER LITE AND TOP ROLLOVER (WHITE) LITE.

## RED RELAY

IS ENERGIZED BY WIPER FINGER ON ADVANCE UNIT DISC.

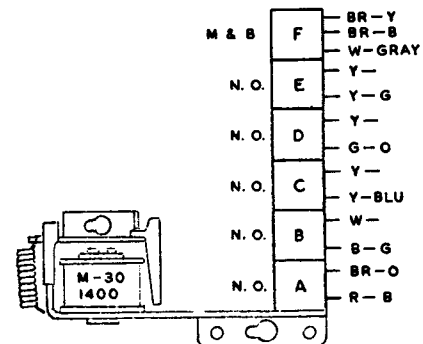

E-20

C-19

C-20

C-19

A-6

F-18

IN CIRCUIT TO 100 POINT OR 300 POINT RELAY.

ENERGIZES WHITE RELAY.

ENERGIZES GREEN RELAY.

ENERGIZES YELLOW RELAY.

TO FOLLOWING ROLLOVER LITES: LEFT AND RIGHT BOTTOM (OUTSIDE), TOP (RED), AND SIDE.

ENERGIZES EXTRA BALL RELAY WHEN SIDE ROLLOVER IS MADE.

# A.C. RELAYS & SWITCHES

(LOCATED ON PLAYFIELD)

## YELLOW RELAY

IS ENERGIZED BY WIPER FINGER ON ADVANCE UNIT DISC. ALSO BY SWITCH "C" ON RED RELAY.

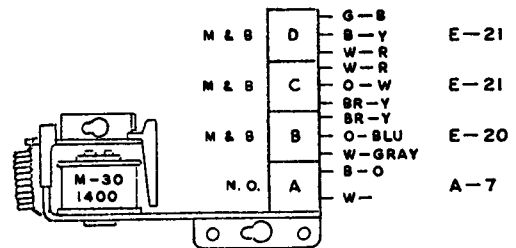

## OPERATION

ENERGIZES 1 POINT RELAY OR 10 POINT RELAY, THRU SWITCH ON NO. 2 BUMPER RELAY.

TO 10 POINT OR 100 POINT RELAY.

TO 100 POINT OR 300 POINT RELAY.

TO FOLLOWING LITES: LEFT BOTTOM AND RIGHT TOP JET BUMPERS, LEFT BOTTOM (INSIDE) R.O., AND TOP R.C. (YELLOW)

## GREEN RELAY

IS ENERGIZED BY WIPER FINGER ON ADVANCE UNIT DISC. ALSO BY SWITCH "D" ON RED RELAY.

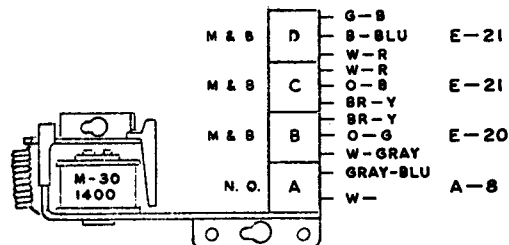

ENERGIZES 1 POINT OR 10 POINT RELAY, THRU SWITCH ON NO. 1 BUMPER RELAY.

TO 10 POINT OR 100 POINT RELAY.

TO 100 POINT OR 300 POINT RELAY.

TO FOLLOWING LITES: LEFT TOP AND RIGHT BOTTOM JET BUMPERS, RIGHT BOTTOM (INSIDE) R.O., AND TOP R.O. (GREEN).

## ADVANCE RELAY

IS ENERGIZED BY ANY OF (4) STAND-UP SWITCHES.

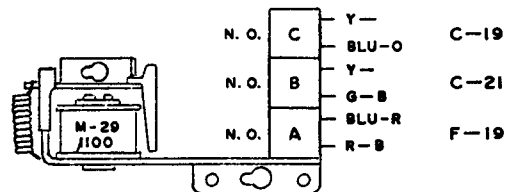

ENERGIZES ADVANCE UNIT S.U. COIL.

PULSES 1 POINT RELAY.

IN HOLD CIRCUIT TO THIS RELAY.

## NO. 3 BUMPER RELAY

IS PULSED BY CENTER JET BUMPER SWITCH

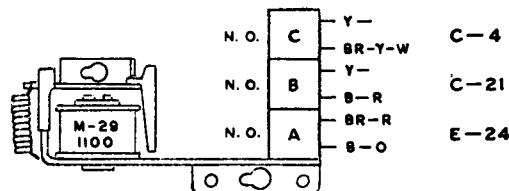

ENERGIZES CENTER JET BUMPER COIL.

IN SERIES WITH SWITCH "C" ON WHITE RELAY.

IN HOLD CIRCUIT TO THIS RELAY.



# A.C. RELAYS & SWITCHES

(LOCATED ON PLAYFIELD)

## NO. 2 BUMPER RELAY

IS PULSED BY RIGHT TOP OR LEFT BOTTOM JET BUMPER SWITCH.

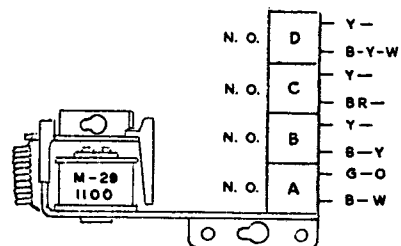

DIAGRAM LOCATION

C-4

ENERGIZES RIGH TOP JET BUMPER COIL.

C-4

ENERGIZES LEFT BOTTOM JET BUMPER COIL.

C-21

IN SERIES WITH SWITCH "D" ON YELLOW RELAY.

E-24

IN HOLD CIRCUIT TO THIS RELAY.

## OPERATION

## NO. 1 BUMPER RELAY

IS PULSED BY LEFT TOP OR RIGHT BOTTOM JET BUMPER SWITCH.

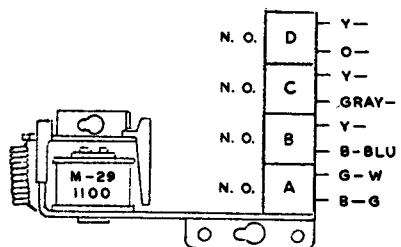

C-4

ENERGIZES RIGHT BOTTOM JET BUMPER COIL.

C-4

ENERGIZES LEFT TOP JET BUMPER COIL

C-21

IN SERIES WITH SWITCH "D" ON GREEN RELAY.

E-24

IN HOLD CIRCUIT TO THIS RELAY.

## 300 RELAY

IS ENERGIZED BY ANY OF THE (4) TOP OR (4) BOTTOM ROLLOVER SWITCHES, WHEN LIT.

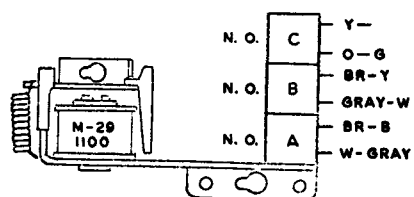

E-5

RUNS SCORE MOTOR

C-22

PULSES 100 POINT RELAY, THRU IMPULSE CAM SW. B.

D-20

HOLD CIRCUIT TO THIS RELAY, THRU CAM SWITCH 3B.

## EJECT RELAY

IS ENERGIZED BY EJECT SWITCH, THRU SCORE MOTOR INDEX CAM SWITCH "C".

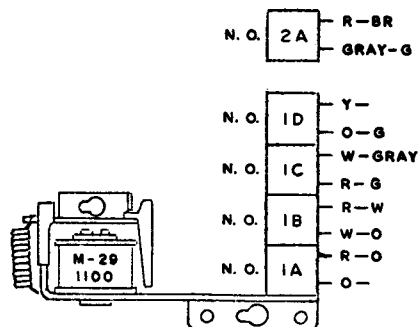

F-16

HOLD CIRCUIT TO THIS RELAY, THRU CAM SWITCH 5A.

C-5

RUNS SCORE MOTOR.

E-20

ENERGIZES 300 POINT RELAY.

C-15

IN SERIES WITH SWITCH "D" ON BONUS RESET RELAY.

E-17

PULSES EJECT COIL, THRU CAM SWITCH 3A.

## A.C. RELAYS & SWITCHES

(LOCATED IN BACK BOX)

### 1 POINT RELAY

IS PULSED BY STAND-UP AND KICKER SWITCHES. ALSO BY NO. 1 BUMPER, NO. 2 BUMPER AND ADVANCE RELAYS.

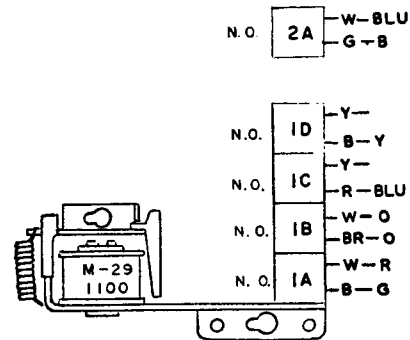

DIAGRAM  
LOCATION

F-22

IN HOLD CIRCUIT TO THIS RELAY.

C-23

ENERGIZES NUMBER MATCH S.U. COIL.

C-7

PULSES DISAPPEARING POST COILS, THRU NUMBER MATCH UNIT DISC.

C-11

PULSES 1 POINT DRUM UNITS, THRU PLAYER UNIT DISC.

F-22

PULSES 10 POINT RELAY, THRU 9th POSITION SWITCHES ON 1 POINT DRUM UNITS.

### 10 POINT RELAY

IS PULSED BY TOP ROLLOVERS (GREEN & YELLOW) AND HITTING JET BUMPERS WHEN INDICATED.

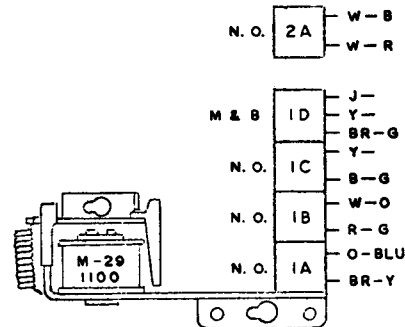

F-22

IN HOLD CIRCUIT TO THIS RELAY.

C-18

OPENS CIRCUIT TO EXTRA BALL RELAY AND ENERGIZES BALL INDEX RELAY.

C-23

PULSES LARGE BELL COIL.

C-12

PULSES 10 POINT DRUM UNITS, THRU PLAYER UNIT DISC.

F-23

PULSES 100 POINT RELAY, THRU 9th POSITION SWITCHES ON 10 POINT DRUM UNITS.

### 100 POINT RELAY

IS PULSED BY SIDE ROLLOVER SWITCH. ALSO IN CIRCUITS CONTROLLED BY RED, WHITE, YELLOW AND GREEN RELAYS. CHECK SWITCH OPERATIONS ON THESE RELAYS.

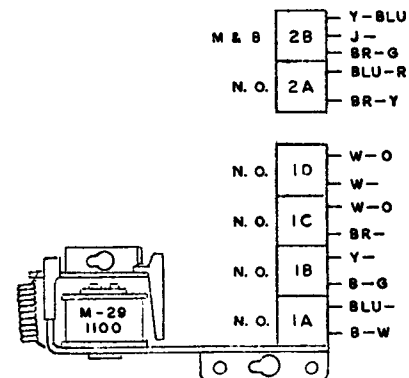

D-18

OPENS CIRCUIT TO EXTRA BALL RELAY AND ENERGIZES BALL INDEX RELAY.

F-22

IN HOLD CIRCUIT TO THIS RELAY.

C-13

PULSES 100 POINT DRUM UNITS, THRU PLAYER UNIT DISC.

C-13

PULSES 1000 POINT DRUM UNITS, THRU 9th POSITION SWITCHES ON 100 POINT DRUM UNITS.

C-24

PULSES LARGE BELL COIL.

G-8

IN HIGH-SCORE CIRCUIT TO REPLAY S.U. COIL.

# A.C. RELAYS & SWITCHE

(LOCATED IN BACK BOX)

DIAGRAM  
LOCATION

OPERATION

## 1ST & 2ND PLAYER RESET RELAY

IS PULSED BY IMPULSE CAM SWITCH "C",  
THRU SWITCH "A" OF RESET RELAY.  
(DURING RESET CYCLE).

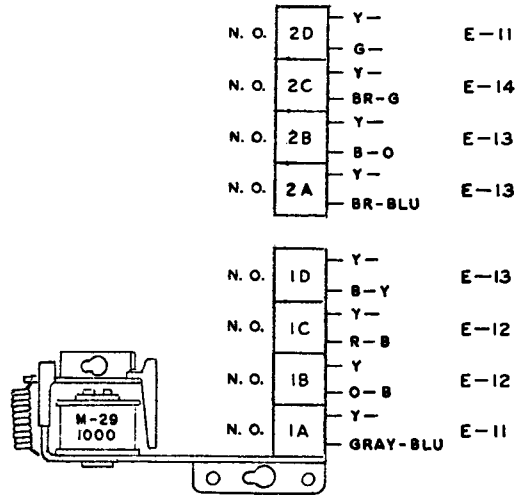

1ST PLAYER 1 POINT DRUM UNIT  
2ND PLAYER 1000 POINT DRUM UNIT  
2ND PLAYER 100 POINT DRUM UNIT  
1ST PLAYER 1000 POINT DRUM UNIT  
1ST PLAYER 100 POINT DRUM UNIT  
2ND PLAYER 10 POINT DRUM UNIT  
1ST PLAYER 10 POINT DRUM UNIT  
2ND PLAYER 1 POINT DRUM UNIT

THESE DRUM UNITS ARE  
PULSED, DURING RESET  
CYCLE, THRU ZERO SW.  
ON THAT UNIT.

## 3RD & 4TH PLAYER RESET RELAY

IS PULSED BY IMPULSE CAM SWITCH "A"  
THRU SWITCH "A" OF RESET RELAY.  
(DURING RESET CYCLE).

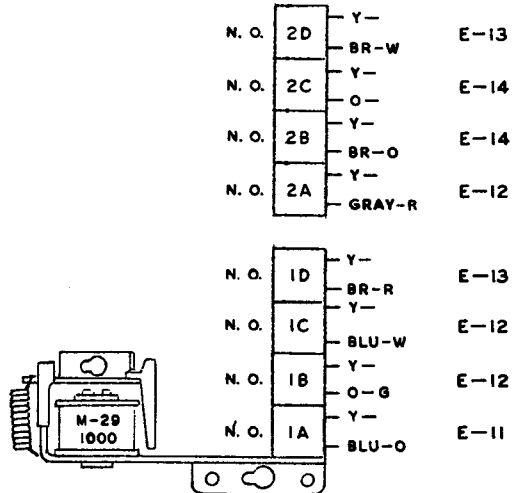

3RD PLAYER 100 POINT DRUM UNIT  
4TH PLAYER 1000 POINT DRUM UNIT  
3RD PLAYER 1000 POINT DRUM UNIT  
4TH PLAYER 10 POINT DRUM UNIT  
4th PLAYER 100 POINT DRUM UNIT  
3RD PLAYER 10 POINT DRUM UNIT  
4TH PLAYER 1 POINT DRUM UNIT  
3RD PLAYER 1 POINT DRUM UNIT

THESE DRUM UNITS ARE  
PULSED, DURING RESET  
CYCLE, THRU ZERO SWITCH  
ON THAT UNIT.

PRICE LIST

ARRANGED IN NUMERICAL ORDER

<u>Part No.</u>	<u>Description</u>	<u>Price</u>
1 B 8-508 T	Coil Bracket .....	.24
1 B 1178	Large 5" Bell .....	1.92
1 A 3251	Relay Armature .....	.42
1 A 4694	Relay Mounting Bracket .....	.34
1 A 4695	Mounting Base .....	.84
1 A 4696	Bell Mounting Bracket .....	.34
1 A 4698	Switch Bracket .....	.18
2 A 3444	Bumper Shaft .....	.46
2 A 3445	Solenoid Armature .....	.40
3 A 7257	Plastic Bumper .....	.80
3 B 7258	Latch Armature .....	.38
10 A 96 A	Relay Spring .....	.06
10 A 306	Shaft Spring .....	.10
20 A 8790	Nylon Bearing .....	.26
23 A 6420	Rubber Grommet .....	.04
23 A 6507	Rubber Bumper .....	.10
24 A 6406	Light Socket .....	.16
24 A 6549	#44 Light Bulb .....	.16
A 5387	Solenoid Plunger Assembly .....	.88
B 6823	Mounting Bracket Assembly .....	1.36
B 6892	Frame & Eyelet Assembly .....	1.06
A 7034	Coil Mounting Bracket Assembly .....	.98
B 7050	5" Bell Complete Unit .....	7.00
B 7089	Complete Disappearing Post Unit .....	12.00
A2-23-750	Coil .....	1.80
G 23-750	Coil .....	1.80
M 29-1000	Coil .....	1.80