

# Instruction Manual

*for*

# SET UP

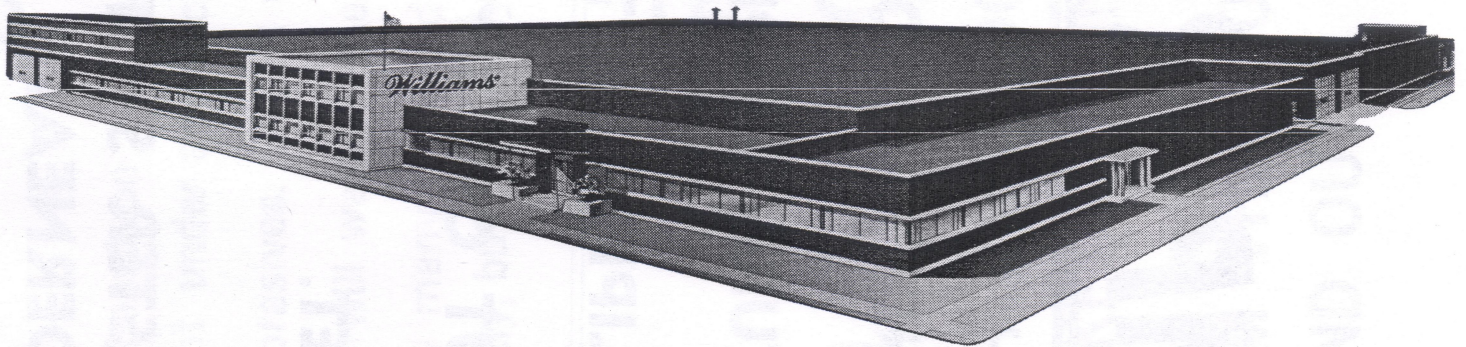

**Williams<sup>®</sup> ELECTRONICS, INC.**

SUBSIDIARY OF THE SEEBURG CORPORATION

3401 N. California Ave.  
Phone 267-2240

Chicago, Ill. 60618, U.S.A.  
Cable Address: Wilcoin



# **IMPORTANT NOTICE**

**KINDLY INFORM LOCATIONS THAT THEY CAN TURN DISPLAY LIGHTS ON BY PRESSING LEFT FLIPPER BUTTON. MACHINE CAN STILL BE SHUT OFF BY TAPPING BOTTOM OF CABINET.**

**MASTER SWITCH (ON-OFF) IS LOCATED UNDERNEATH FRONT PART OF CABINET.**



## **CAUTION!**

The playboard on this machine has an improved finish with excellent wearing properties. Do not under any circumstances clean the board with water, water soap solutions or harsh abrasives. Avoid such things as steel wool, kitchen cleansers or abrasive hand soap. Water will weaken the adhering of the paint to the board and abrasives shorten the board life by many thousand plays. A wax base cleaner with negligible abrasive qualities used lightly, but frequently, will extend the board life to its full capabilities.

---

## **SERVICEMAN TO REMOVE BACKGLASS:**

- WITH BACK DOOR REMOVED, PULL BACK ON BRACKETS AT INSIDE TOP OF LITE BOX.**
- FROM THE FRONT OF GAME, LIFT GLASS UP AND OUT.**



# ALTERNATOR UNIT

LOCATED ON MECHANISM PANEL.

USED IN CONJUNCTION WITH 5¢ RELAY FOR "2 COINS-1 PLAY" FEATURE.

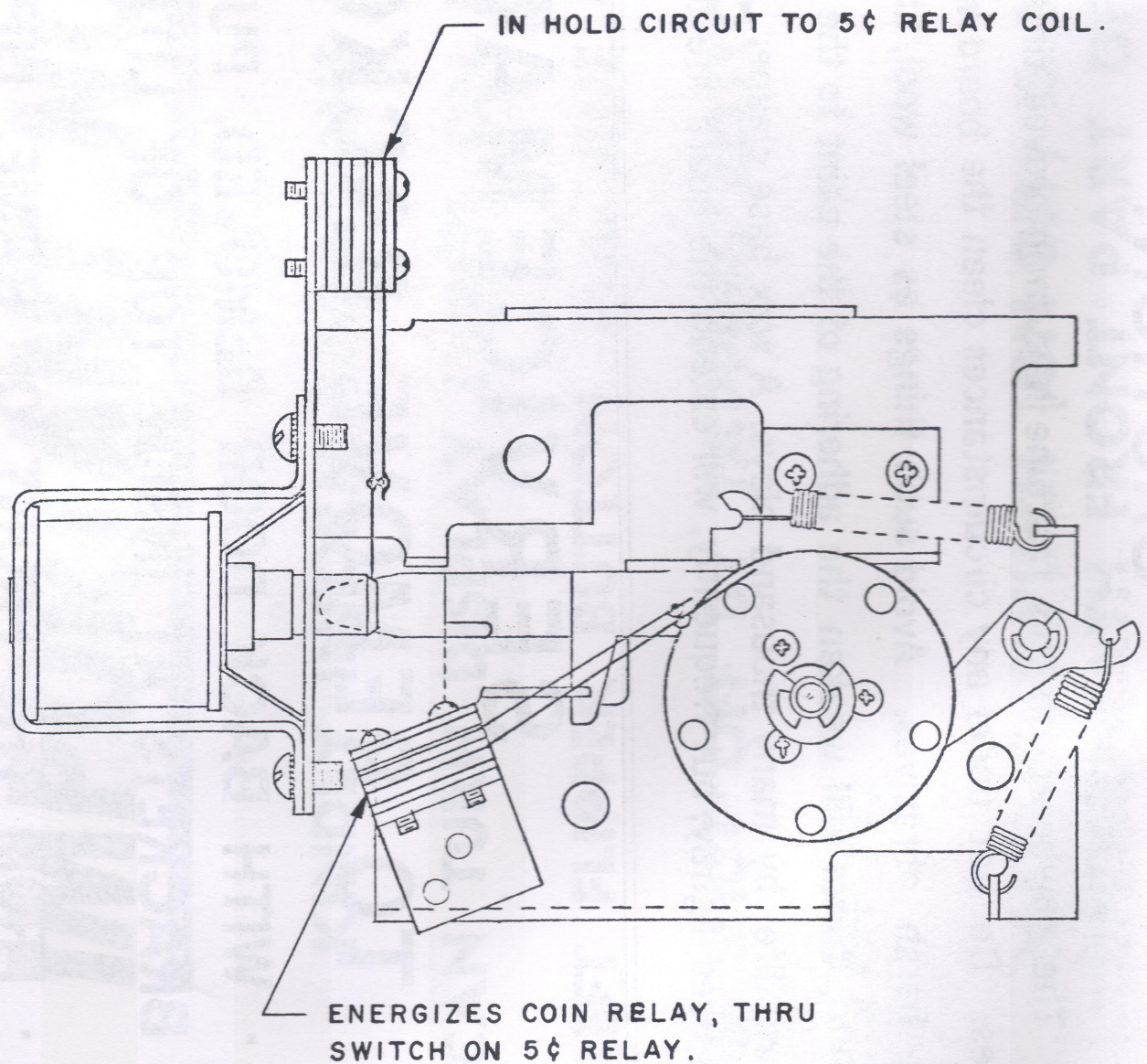



# INSTRUCTIONS FOR COIN TRIP SWITCH ADJUSTMENT

WIRE SHOULD BE IN CONTACT WITH END OF CRESCENT OPENING WHEN BLADE ADJUSTMENT IS MADE.

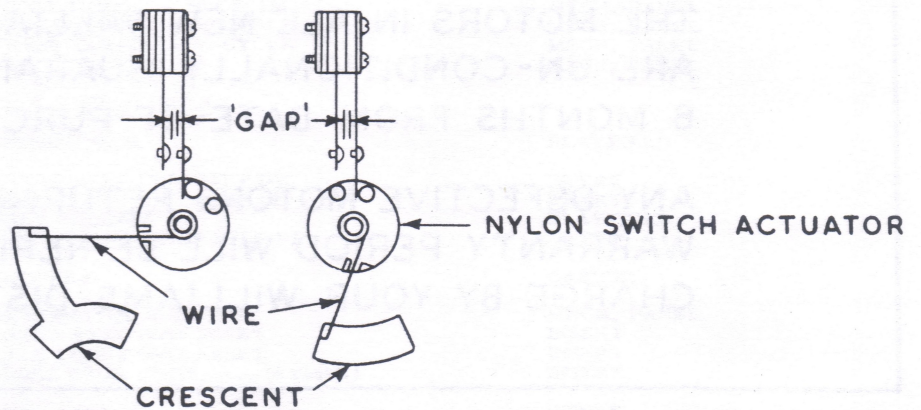

Long blade should be in contact with nylon switch actuator and have a maximum overtravel of  $1/32$ .

or

Using a gram gauge, tension of long blade should not exceed 10 grams.

## SWITCH ADJUSTMENT

1. For small coins, such as dimes, adjust short blade so that the 'gap' between the silver contacts is .045 to .055.
2. For larger & heavier coins the 'gap' should be .045 to .060.
3. Do not adjust 'gap' closer than .040.



# WARRANTY

THE MOTORS IN ALL NEW WILLIAMS PRODUCTS  
ARE UN-CONDITIONALLY GUARANTEED FOR  
6 MONTHS FROM DATE OF PURCHASE.

ANY DEFECTIVE MOTORS RETURNED DURING THE  
WARRANTY PERIOD WILL BE REPLACED FREE OF  
CHARGE BY YOUR WILLIAMS DISTRIBUTOR.

## IMPORTANT NOTICE

WHEN ORDERING PARTS ALWAYS SPECIFY NAME OF  
UNIT, GAME AND SERIAL NUMBER, IN ADDITION TO A  
CLEAR DESCRIPTION OF THE PART AND PART  
NUMBER IF POSSIBLE.

### UNIT PARTS LIST

UNIT NAME	CONTACT DISC	WIPER ASSEMBLY	RATCHET GEAR ASSEMBLY	MOTORS
BALL COUNT	C-6937	C-6520	A-6402-5	
EXTRA BALL	C-7164	C-6520	A-6402-5	
MAN ADVANCE	C-6417	C-6521	A-6403	14A-7805 (60 CYCLE)
TENS	-----	-----	3C-7272	
HUNDREDS	-----	-----	3C-7272	14A-7806 (50 CYCLE)
THOUSANDS	-----	-----	3C-7272	
TEN THOUSANDS	A-7195	A-6294	3C-7272	
ALTERNATOR	*****	-----	3C-7272	



"SET UP" COIL CHART

NOTICE:

THIS GAME OPERATES ON 24 VOLTS. WHEN ORDERING REPLACEMENT TRANSFORMERS, MOTORS, COILS OR METERS ... MAKE SURE TO SPECIFY CORRECT PART NUMBER.

NUMBER	DESCRIPTION	LOCATION
14 A 7805	SCORE MOTOR - 60 CYCLE	MECH. PANEL
14 A 7806	SCORE MOTOR - 50 CYCLE	MECH. PANEL
15 A 6771	TRANSFORMER - 60 CYCLE	MECH. PANEL
15 A 6773	TRANSFORMER - 50 CYCLE	MECH. PANEL
B 6396	24 VOLT METER	MECH. PANEL
<u>SOLENOID COILS</u>		
A 21-400	KICKOUT COIL	PLAYFIELD
A 22-550	EXTRA BALL UNIT STEP UP BALL COUNT UNIT STEP UP BALL RELEASE MAN ADVANCE UNIT STEP UP	INSERT INSERT PLAYFIELD INSERT
A 2-23-750	KNOCKER	CABINET
B 26-800	ALTERNATOR UNIT EXTRA BALL UNIT RESET BALL COUNT UNIT RESET SCORE DRUM UNITS .... (4 req'd.)	MECH. PANEL INSERT INSERT INSERT
C2-26-800	SMALL BELL CHIME	INSERT INSERT
D 24-1400	RELAY BANK RESET COIL	PLAYFIELD
G 22-550	JET BUMPERS .... (4 req'd.) CENTER TARGET	PLAYFIELD PLAYFIELD
G 23-600	KICKOUT UNIT (LATCH)	PLAYFIELD
G 23-750	AUTO KICKERS .... (2 req'd.) DOWN L POST DOWN R POST DOWN CENTER POST	PLAYFIELD PLAYFIELD PLAYFIELD PLAYFIELD
FL 21-375/ 28-400	FLIPPERS .... (4 req'd.)	PLAYFIELD
<u>RELAY COILS</u>		
M1-31-1500	COIN LOCKOUT	DOOR
M2-25-400	KICKOUT UNIT (TRIP)	PLAYFIELD
M 30-1400	KICKOUT RELAY SPECIAL RELAY E RELAY	PLAYFIELD PLAYFIELD PLAYFIELD
M 29-1000	GAME TRIP GAME OVER TRIP RESET L POST (TRIP) R POST (TRIP) CENTER POST (TRIP)	MECH. PANEL MECH. PANEL MECH. PANEL PLAYFIELD PLAYFIELD PLAYFIELD
M 29-1100	5¢ RELAY 10 POINT RELAY 100 POINT RELAY 1,000 POINT RELAY NO. 1 BUMPER RELAY NO. 2 BUMPER RELAY NO. 3 BUMPER RELAY NO. 4 BUMPER RELAY MAN ADVANCE RELAY CENTER POST RELAY SIDE POST RELAY	MECH. PANEL INSERT INSERT INSERT PLAYFIELD PLAYFIELD PLAYFIELD PLAYFIELD PLAYFIELD PLAYFIELD PLAYFIELD
Z 27-1000	GAME LATCH GAME OVER LATCH 3,000 RELAY CENTER TARGET RELAY COIN RELAY OUTHOLE RELAY 2 PLAY RELAY RESET RELAY 5,000 RELAY	MECH. PANEL MECH. PANEL MECH. PANEL MECH. PANEL MECH. PANEL MECH. PANEL MECH. PANEL MECH. PANEL MECH. PANEL
Z 28-1150	LOCK RELAY CREDIT RELAY	MECH. PANEL MECH. PANEL
Z 28-1200	BALL INDEX RELAY	MECH. PANEL
S 27-500	RELAY BANK COILS .... (6 req'd.)	PLAYFIELD
XM 27-675	METER COIL	MECH. PANEL
M 30-1300	10,000 RELAY	INSERT



## ON MECHANISM PANEL

### Motor Service Jack

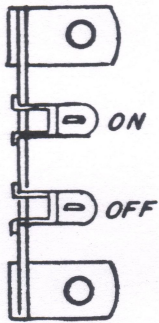

INSERT PHONE TIP IN 'OFF' POSITION - CAMS CAN BE TURNED BY HAND TO CHECK

ADJUSTMENT OF SWITCHES.

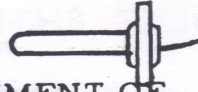

## MASTER ON-OFF SW.

(Located under front of Cabinet)

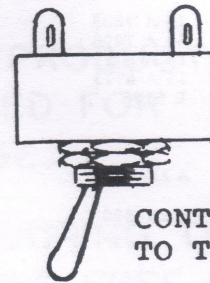

CONTROLS POWER TO TRANSFORMER

## ADJUSTMENTS IN BACKBOX

### GAME ADJUSTMENT

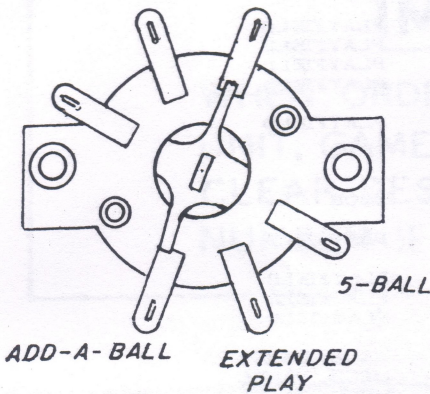

IN ADD-A-BALL POSITION, HI-SCORES, AND "SPECIAL" WILL REGISTER EXTRA BALLS.

EXTENDED PLAY POSITION: SAME AS ADD-A-BALL EXCEPT BALL IS AUTOMATICALLY EJECTED BACK ONTO PLAY-FIELD.

5 BALL POSITION: "SPECIAL" SCORES 10,000 POINTS.

NOTE: ALL PHONE TIPS MUST BE REMOVED FROM "EXTRA-BALL-HI-SCORE" ADJUSTMENT JACK.

### EXTRA BALL HI-SCORE ADJ.

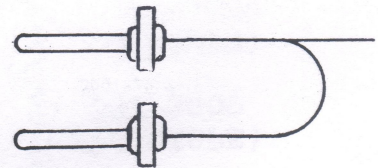
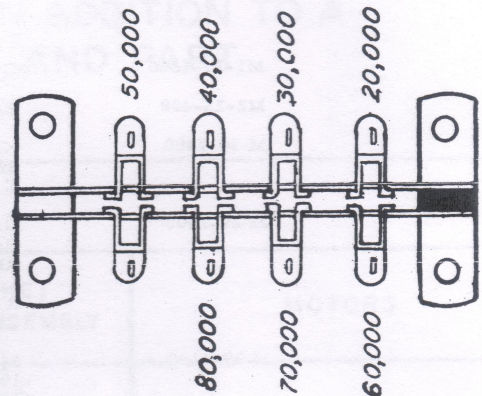

INSERT PHONE TIPS INTO POSITIONS AT WHICH EXTRA BALL IS AWARDED.

SUGGESTED SCORE CARD  
373-1EB



# "SET UP" — POST ADJUSTMENT SHEET

TO MAKE GAME MORE "CONSERVATIVE" OR "LIBERAL"—MOVE POSTS 3/16" AS SHOWN IN SKETCH BELOW. SPOTTING HOLES ARE PROVIDED AND CAN BE SEEN ON REMOVAL OF POSTS.

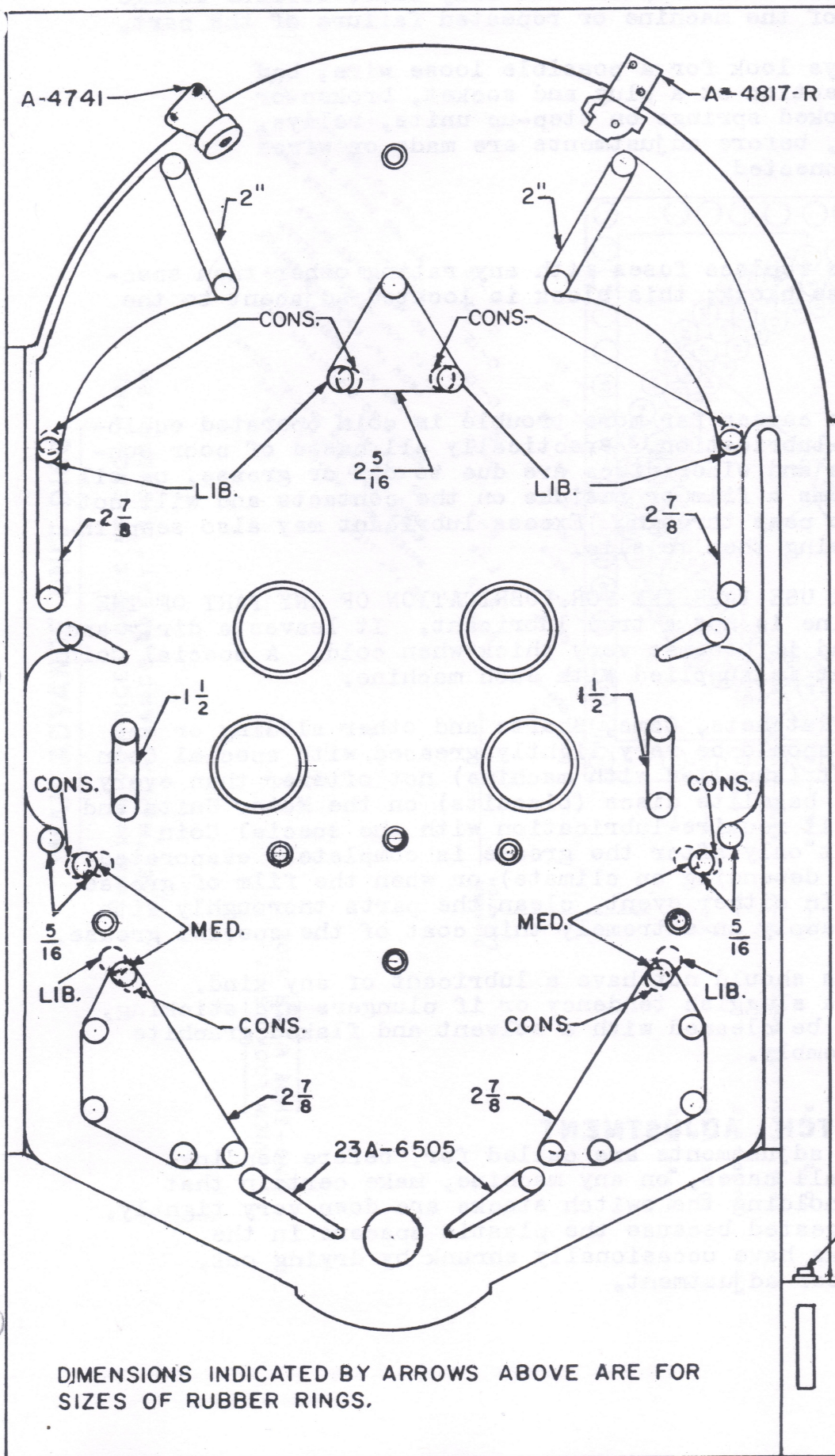

ABBREVIATIONS:  
 CONS.— CONSERVATIVE  
 LIB.—LIBERAL  
 MED.—MEDIUM

RUBBER RING NUMBERS:

23A-6300	5/16	I.D.
23A-6304	1-1/2	I.D.
23A-6305	2"	I.D.
23A-6306	2-5/16	I.D.
23A-6307	2-7/8	I.D.

A-4817-R— BALL GATE ASS  
 A-4741 REBOUND ASS'Y

23A-6327 BALL SHOOTER  
 RUBBER TIP

DIMENSIONS INDICATED BY ARROWS ABOVE ARE FOR SIZES OF RUBBER RINGS.



## 1. GENERAL

NEVER EXPERIMENT with any of the mechanism. Locate any trouble with the aid of Wiring Diagrams or Operating & Servicing Information supplied with the machine, then check for proper adjustment of the units involved before making any changes. Improper adjustment or make-shift repair will only cause serious damage to other parts of the machine or repeated failure of the part.

NOTE: Always look for a possible loose wire, bad connection at a plug and socket, broken or unhooked springs on step-up units, relays, etc., before adjustments are made or wires reconnected.

## 2. FUSES

IMPORTANT: Never replace fuses with any rating other than specified on the fuse block; this block is located adjacent to the transformer.

## 3. LUBRICATION

Over-lubrication causes far more trouble in coin operated equipment than under-lubrication. Practically all cases of poor contact on switches and wiper discs are due to oil or grease, or oil vapor, which forms a film or residue on the contacts and will not allow current to pass through. Excess lubricant may also seep into clutches causing them to slip.

IMPORTANT: NEVER USE VASELINE FOR LUBRICATION OF ANY PART OF THE MACHINE. Vaseline is not a true lubricant. It leaves a dirty and gummy residue and it becomes very thick when cold. A special Coin Machine Lubricant is supplied with each machine.

STEP-UP Levers, Ratchets, Cams, Shafts and other sliding or oscillating parts should be very lightly greased with special Coin Machine Lubricant (supplied with machine) not oftener than every six months. The bakelite discs (biscuits) on the Motor Units and Step-up Units will require lubrication with the special Coin Machine Lubricant only after the grease is completely evaporated (3 to 12 months, depending on climate) or when the film of grease becomes dirty. In either event, clean the parts thoroughly with a solvent, then apply an extremely thin coat of the special grease.

Solenoid Plungers should not have a lubricant of any kind. Should there be a sluggish tendency or if plungers are sticking, the parts should be cleaned with a solvent and flaked graphite applied on reassembly.

## 4. RELAY and SWITCH ADJUSTMENT

Where relay adjustments are called for, before bending blades, in all cases, on any machine, make certain that the screws holding the switch stacks are down very tightly. This is suggested because the plastic spacers in the switch stacks have occasionally shrunk by drying out, causing a poor adjustment.



# MAN ADVANCE UNIT DISC

THIS UNIT ADVANCES ONE STEP EACH TIME THE "MAN ADVANCE RELAY" IS ENERGIZED.

VIEW LOOKING AT SNO-SHOE WIPER SIDE

TO "A" LITE  
 SKIERS NO. 9 POSITION LITE  
 THROUGH SPECIAL RELAY  
 SKIERS NO. 2 POSITION RELAY  
 FROM "A" ROLLOVER SWITCH  
 TO MAN ADVANCE RELAY  
 FROM "E" ROLLOVER SWITCH  
 TO 100 POINT RELAY  
 FROM "D" ROLLOVER SWITCH  
 TO 100 POINT RELAY

DIAGRAM LOCATION

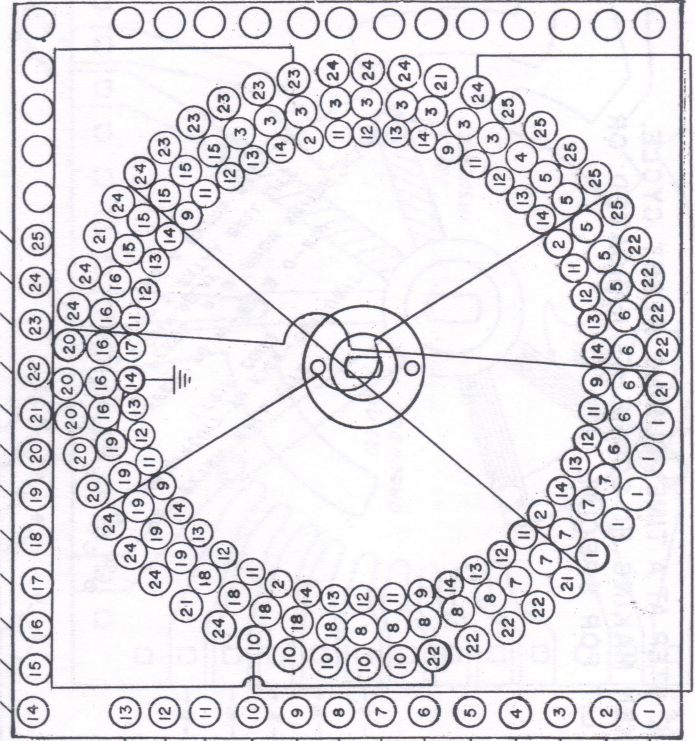

- TO "B" LITE
- TO "C" LITE
- TO "D" LITE
- FROM "B" ROLLOVER SWITCH
- TO "E" LITE
- TO NO. 3 POSITION LITE
- TO NO. 4 POSITION LITE
- TO NO. 5 POSITION LITE
- TO NO. 6 POSITION LITE
- TO NO. 7 POSITION LITE
- TO NO. 8 POSITION LITE
- TO "E" RELAY
- FROM "C" ROLLOVER SWITCH

- F-6
- F-6
- F-6
- D-12
- F-6
- B-4
- B-4
- B-4
- B-5
- B-5
- B-5
- E-7
- D-13



# EXTRA BALL UNIT DISC

THIS UNIT RESETS TO ZERO, ONE STEP AT A TIME, DURING RESET CYCLE. DURING PLAY, IT ADVANCES WHEN MAKING HI-SCORE AS INDICATED, OR RIGHT SIDE ROLLOVER WHEN LIT FOR SPECIAL.

Y-0  
Y-R  
Y-ALU  
Y-ALU B  
D-6  
D-5  
B-3  
B-3  
C-15  
B-3  
No. 1 EXTRA BALL LITE IN CIRCUIT TO KICK-OUT UNIT  
FEED TO W-BR & O-BLU  
FEEDS R-B FROM SWITCH "F" ON  
No. 5 EXTRA BALL LITE  
No. 4 EXTRA BALL LITE

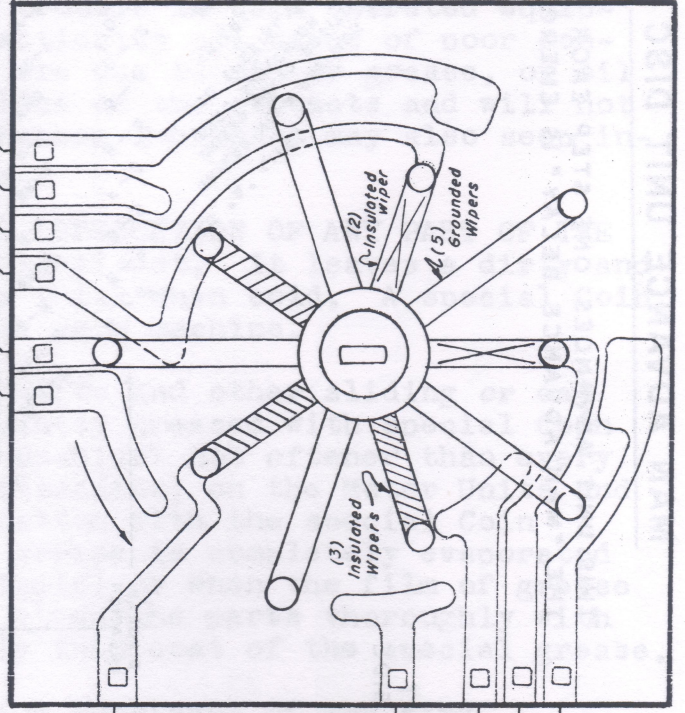

CIRCUIT TO BALL COUNT UNIT RESET COIL D-6

No. 2 EXTRA BALL LITE B-3

CIRCUIT TO EXTRA BALL UNIT RESET COIL E-6

TO GAME RELAY (LATCH COIL) D-5

No. 3 EXTRA BALL LITE B-3

View Looking at WIPER FINGERS, with wiper in ZERO POSITION.

NOTE: Always look for a possible loose connection at a plug and socket, unhooked springs on step-up unit etc., before adjustments are made.



# BALL COUNT S. U. DISC

THIS UNIT ADVANCES FIVE STEPS AT START OF NEW GAME. IT RESETS ONE STEP EACH TIME THE BALL LEAVES THE PLAYFIELD (MAKES THE OUTHOLE SWITCH), IF EXTRA BALL UNIT IS IN ZERO POSITION.

View looking at WIPER FINGERS side  
with WIPER in ZERO position

DIAGRAM LOCATION

- |       |   |     |
|-------|---|-----|
| BALLS | 1 | B-2 |
| TO    | 2 | B-3 |
| PLAY  | 3 | B-3 |
| LITES | 4 | B-3 |
|       | 5 | B-3 |

- |   |     |
|---|-----|
| FEEDS - G - B R-6 (BELOW) FROM BALL INDEX & OUTHOLE RELAY SWITCHES. | C-6 |
| TO GAME OVER RELAY (TRIP COIL)                                      | C-5 |
| TO GAME OVER RELAY (LATCH COIL)                                     | C-5 |

Y-0  
Y-8  
A-6 TO TILT LITE  
A-6 TO GAME OVER LITE  
C-5 TO GAME RELAY (LATCH COIL)  
C-5 TO FEED TO R-BLU FROM SW ON COIN RELAY

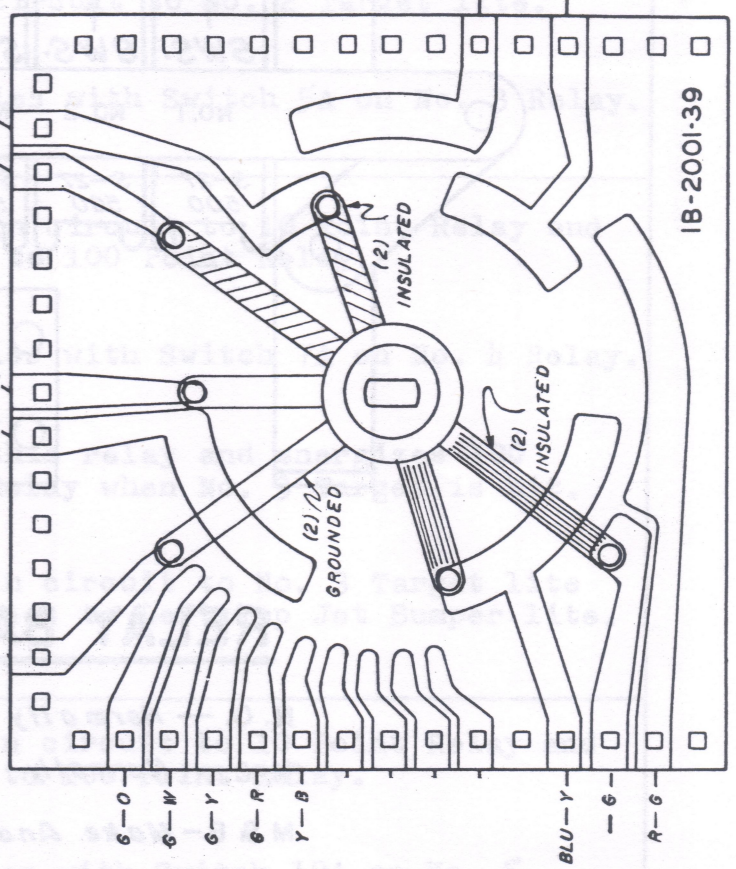



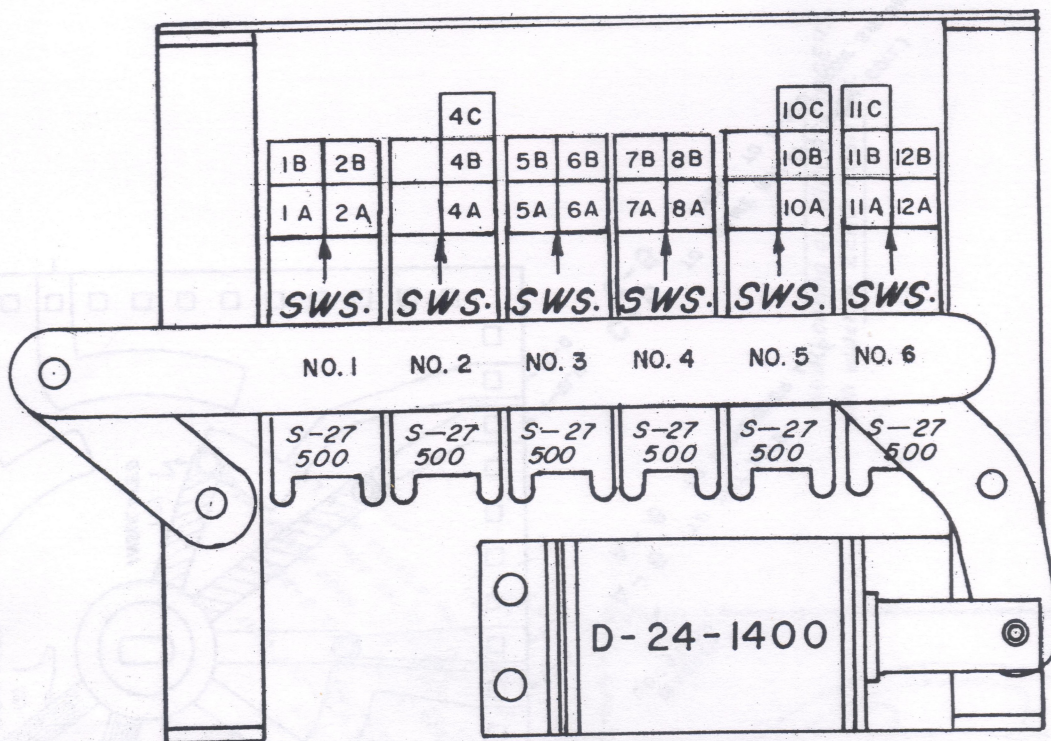

## RELAY BANK SWS.

- N. O. — *Normally Open Switch*  
 N. C. — *Normally Closed Switch*  
 M & B — *Make And Break Switch*

RELAY	SW.	WIRE COLORS	DIAGRAM LOCATION	TYPE	SWITCH OPERATION
NO. 1 RELAY	1B	O-BLU -Y- O-G	B-6	M&B	Opens to No. 1 Target lite, and closes to Left Bottom Jet Bumper lite.
	1A	W-BLU -J-	C-10	N.O.	In series with Switch 4A on No. 2 Relay.
	2B	-J- BLU-Y W-R	E-11	M&B	Trips this relay and pulses 100 Point Relay when No. 1 Target is hit.
	2A	G-B -BR- W-R	E-14	M&B	Opens in circuit to 10 Point Relay and closes to 100 Point Relay.



RELAY	SW.	WIRE COLORS	DIAGRAM LOCATION	TYPE	SWITCH OPERATION
NO. 2 RELAY	4C	-J- BLU-W W-R	E-11	M&B	Trips this relay and pulses 100 Point Relay when No. 2 Target is hit.
	4B	-Y- O-W	B-6	N.C.	Opens circuit to No. 2 Target lite.
	4A	-J- -J-	D-10	N.O.	In series with Switch 5A on No. 3 Relay.
NO. 3 RELAY	5B	G-B W-B W-R	E-14	M&B	Opens in circuit to 10 Point Relay and closes to 100 Point Relay.
	5A	-J- -J-	D-10	N.O.	In series with Switch 7A on No. 4 Relay.
	6B	-J- BLU-BR W-R	E-12	M&B	Trips this relay and energizes 100 Point Relay when No. 3 Target is hit.
	6A	O-B -Y- B-R	B-7	M&B	Opens in circuit to No. 3 Target lite and closes to Left Top Jet Bumper lite.
NO. 4 RELAY	7B	G-B W-GRAY W-R	E-14	M&B	Opens in circuit to 10 Point Relay and closes to 100 Point Relay.
	7A	-J- -J-	E-10	N.O.	In series with Switch 10A on No. 5 Relay.
	8B	-J- BLU-O W-R	E-12	M&B	Trips this relay and pulses 100 Point Relay when No. 4 Target is hit.
	8A	B-BLU -Y- B-Y	B-7	M&B	Opens in circuit to No. 4 Target lite and closes to Right Top Jet Bumper lite.
NO. 5 RELAY	10C	-J- BLU-B W-R	E-12	M&B	Trips this relay and pulses 100 Point Relay when No. 5 Target is hit.
	10B	-Y- B-W	B-7	N.C.	Opens circuit to No. 5 Target lite.
	10A	-J- -J-	E-10	N.O.	In series with Switch 11A on No. 6 Relay.



RELAY	SW.	WIRE COLORS	DIAGRAM LOCATION	TYPE	SWITCH OPERATION
NO. 6 RELAY	11C	G-B BR-R W-R	E-14	M&B	Opens in circuit to 10 Point Relay and closes to 100 Point Relay.
	11B	GRAY-Y -Y- GRAY-BLU	B-7	M&B	Opens circuit to No. 6 Target lite and closes to Right Bottom Jet Bumper lite.
	11A	Y-G -J-	F-10	N.O.	Energizes 3000 Relay, thru Switches on No. 1, 2, 3, 4 & 5 Relays.
	12B	-J- Y-BLU W-R	E-12	M&B	Trips this relay and pulses 100 Point Relay when No. 6 Target is hit.
	12A	Y-BR G-Y	C-11	N.C.	In circuit to Center Target Coil when 3000 Relay is energized.



# A.C. RELAYS & SWITCHES

Located on Mechanism Panel

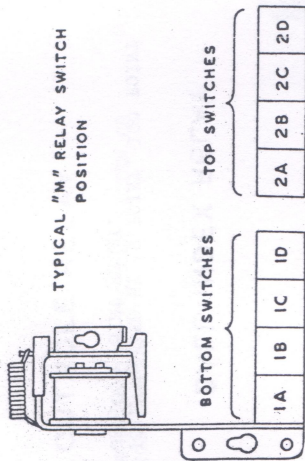

## 5¢ RELAY

THIS RELAY IS USED ONLY ON GAMES WITH 2 COINS FOR 1 PLAY FEATURE. IT IS ENERGIZED BY 5¢ COIN SWITCH.

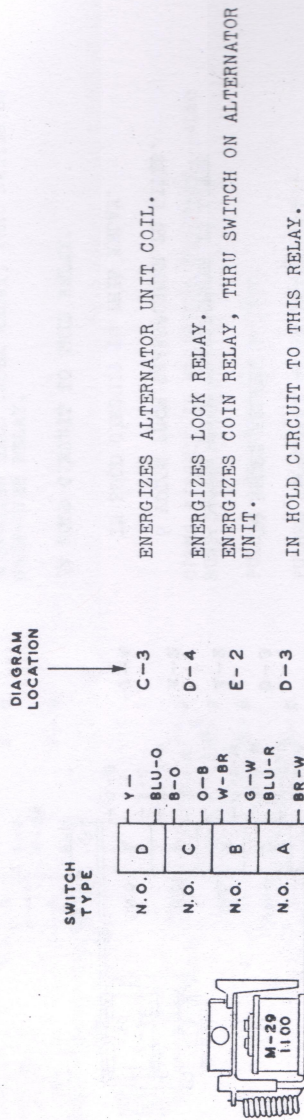

## 2 PLAY RELAY

THIS RELAY IS USED ONLY ON GAMES WITH 1 COIN FOR 2 PLAYS FEATURE. IT IS ENERGIZED BY 2 PLAY COIN SWITCH.

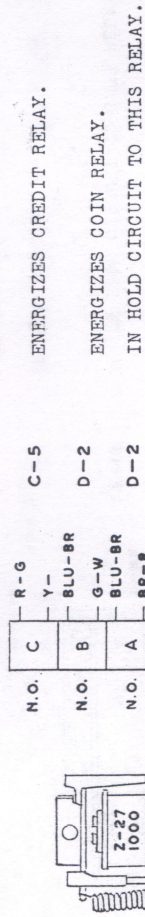

## CREDIT RELAY

IS ENERGIZED BY THE 2 PLAY RELAY.

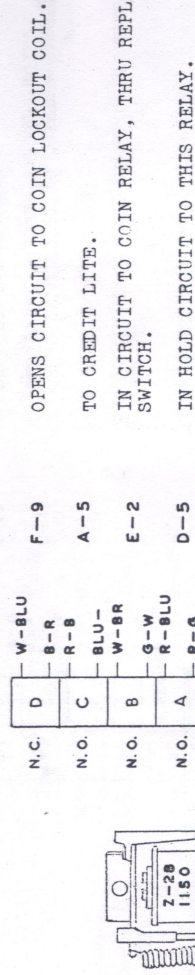

## CENTER TARGET RELAY

IS ENERGIZED BY CENTER TARGET SWITCHES.

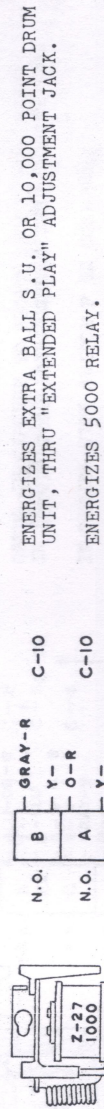



### 5000 RELAY

IS ENERGIZED BY CENTER TARGET RELAY.

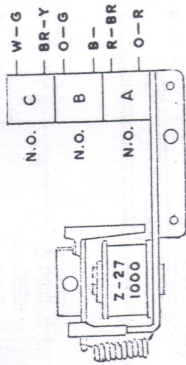

DIAGRAM LOCATION

E-13  
F-3  
F-10

PULSES 1000 POINT RELAY, THRU IMPULSE CAM SWITCH B.  
RUNS SCORE MOTOR.  
IN HOLD CIRCUIT TO THIS RELAY.

### 3000 RELAY

IS ENERGIZED WHEN ALL 6 RELAYS ON RELAY BANK ARE TRIPPED.

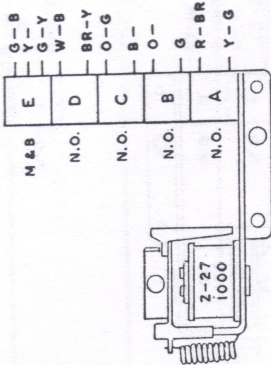

OPENS IN CIRCUIT TO "CENTER TARGET RELAY" AND CLOSES TO "CENTER TARGET" COIL.  
TO 1000 POINT RELAY.  
RUNS SCORE MOTOR.  
ENERGIZES RELAY BANK RESET COIL, THRU CAM SWITCH 30.  
IN HOLD CIRCUIT TO THIS RELAY.

### LOCK RELAY

IS ENERGIZED BY COIN RELAY OR LEFT FLIPPER SWITCH.

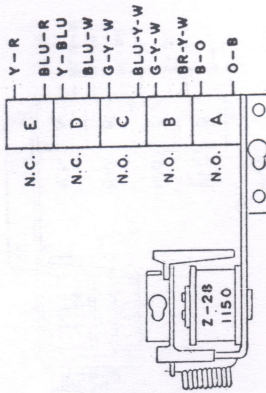

TO GAME OVER RELAY (TRIP COIL).  
TO RESET RELAY.  
6 VOLTS FROM TRANSFORMER TO LITES.  
6 VOLTS FROM TRANSFORMER TO LITES.  
IN HOLD CIRCUIT TO THIS RELAY.

### BALL INDEX RELAY

IS ENERGIZED BY 10 POINT, 100 POINT OR 1000 POINT RELAY.

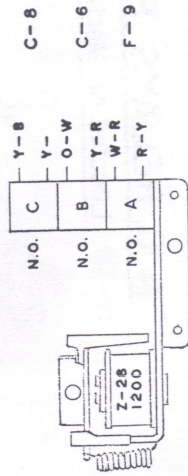

ENERGIZES GAME RELAY (TRIP COIL).  
IN CIRCUIT TO BALL COUNT UNIT RESET COIL AND GAME-OVER RELAY (TRIP COIL).  
IN HOLD CIRCUIT TO THIS RELAY.



## OUTHOLE RELAY

IS ENERGIZED BY OUTHOLE SWITCH OR KICKOUT SWITCH.

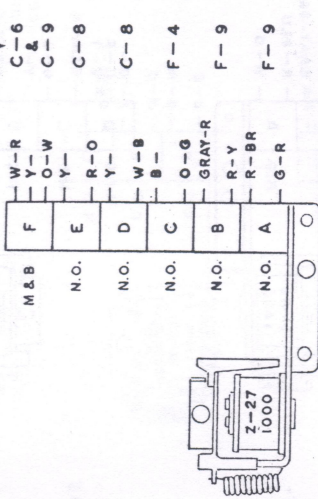

IN HOLD CIRCUIT TO BALL INDEX RELAY---ALSO CONTROLS KICKOUT AND BALL RELEASE COILS.  
TO "DOWN CENTER POST" COIL.  
TO "DOWN LEFT POST" COIL.  
RUNS SCORE MOTOR.  
ENERGIZES BALL INDEX RELAY, THRU SWITCH ON GAME-OVER RELAY.  
IN HOLD CIRCUIT TO THIS RELAY.

## RESET RELAY

IS ENERGIZED BY COIN RELAY.

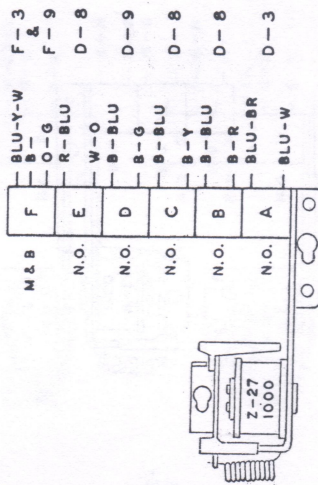

OPENS CIRCUIT TO PLAYFIELD SWITCHES---ALSO RUNS SCORE MOTOR.  
PULSES 100 POINT DRUM UNIT.  
PULSES 10,000 POINT DRUM UNIT.  
PULSES 1000 POINT DRUM UNIT.  
PULSES 10 POINT DRUM UNIT.  
IN HOLD CIRCUIT TO THIS RELAY.

## COIN RELAY

IS ENERGIZED BY COIN SWITCH OR 2 PLAY RELAY. ALSO BY REPLAY BUTTON WHEN CREDIT IS AVAILABLE.

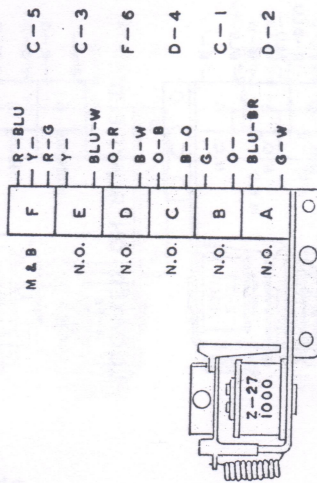

IN CIRCUIT TO PULSE BALL COUNT UNIT RESET COIL AND STEP-UP COIL.  
ENERGIZES RESET RELAY.  
IN CIRCUIT TO BALL COUNT UNIT RESET COIL.  
ENERGIZES LOCK RELAY.  
ENERGIZES RELAY BANK RESET COIL, THRU CAM SWITCH 3C.  
IN HOLD CIRCUIT TO THIS RELAY.

## GAME RELAY (INTERLOCK)

LATCH COIL IS ENERGIZED BY COIN RELAY WHEN EXTRA BALL UNIT AND BALL COUNT UNIT ARE IN ZERO POSITION. TRIP COIL IS ENERGIZED BY BALL INDEX RELAY.

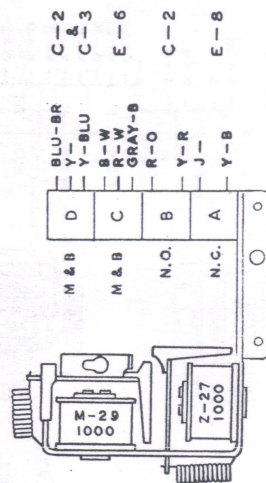

OPENS IN CIRCUIT TO RESET RELAY, AND CLOSES IN HOLD CIRCUIT TO COIN RELAY.  
IN SERIES WITH SWITCH F ON COIN RELAY.  
IN SERIES WITH 10 $\phi$  COIN SWITCH.  
TO GAME RELAY (TRIP COIL).



### GAME OVER RELAY (INTERLOCK)

LATCH COIL IS ENERGIZED BY COIN RELAY.  
TRIP COIL IS ENERGIZED BY OUTHOLE  
RELAY AND BALL INDEX RELAY, THRU BALL  
COUNT UNIT DISC.

DIAGRAM  
LOCATION

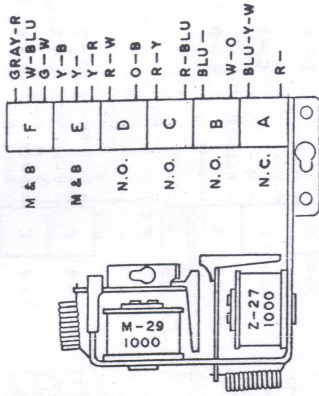

OPENS IN CIRCUIT TO OUTHOLE RELAY AND CLOSES  
TO BALL INDEX RELAY.  
ENERGIZES GAME RELAY (TRIP COIL)---ALSO IN  
CIRCUIT TO GAME-OVER RELAY (TRIP-COIL).  
ENERGIZES SIDE POST RELAY.  
ENERGIZES CENTER POST RELAY.  
TO "GAME OVER" LITE AND "TILT" LITE.  
OPENS CIRCUIT TO PLAYFIELD SWITCHES.

### CENTER POST RELAY

IS ENERGIZED BY ROLLOVER BUTTON AS  
INDICATED. ALSO BY SWITCH ON GAME-  
OVER RELAY.

LOCATED ON PLAYFIELD

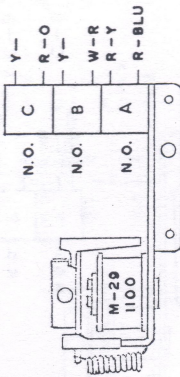

TO "DOWN CENTER POST" COIL.  
ENERGIZES 100 POINT RELAY.  
HOLD CIRCUIT TO THIS RELAY, THRU E.O.S.  
SWITCH ON CENTER POST.

### SIDE POST RELAY

IS ENERGIZED BY ROLLOVER BUTTON AS  
INDICATED. ALSO BY SWITCH ON GAME-  
OVER RELAY.

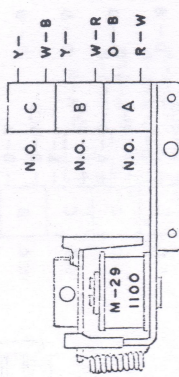

ENERGIZES "DOWN LEFT POST" AND "DOWN RIGHT  
POST" COILS.  
ENERGIZES 100 POINT RELAY.  
IN HOLD CIRCUIT TO THIS RELAY.

### KICK OUT RELAY

IS ENERGIZED BY KICKOUT UNIT END-OF-  
STROKE SWITCH.

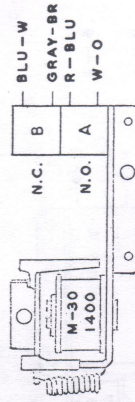

OPENS CIRCUIT TO KICKOUT UNIT (LATCH COIL).  
IN CIRCUIT TO KICKOUT UNIT (TRIP COIL).

### SPECIAL RELAY

IS ENERGIZED BY WIPER FINGER ON MAN  
ADVANCE UNIT.

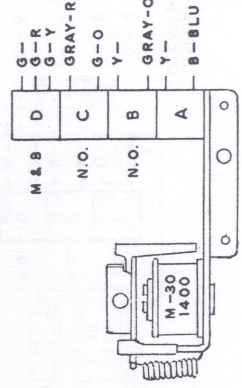

CLOSES TO SKIERS "FINISH" LITE AND RIGHT SIDE  
ROLLOVER "SPECIAL" LITE.  
IN CIRCUIT TO EXTRA BALL UNIT STEP-UP COIL.  
TO RIGHT SIDE ROLLOVER "SPECIAL" LITE.  
TO "E" LITE.



### NO. 1 BUMPER RELAY

IS ENERGIZED BY LEFT TOP BUMPER SWITCH.

DIAGRAM LOCATION

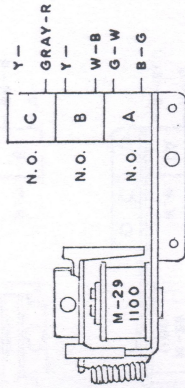

ENERGIZES LEFT TOP JET BUMPER COIL.  
ENERGIZES 10 POINT OR 100 POINT RELAY.  
IN HOLD CIRCUIT TO THIS RELAY.

### NO. 2 BUMPER RELAY

IS ENERGIZED BY RIGHT TOP JET BUMPER SWITCH.

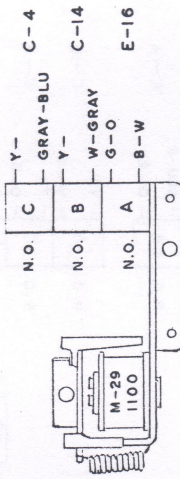

ENERGIZES RIGHT TOP JET BUMPER COIL.  
ENERGIZES 10 POINT OR 100 POINT RELAY.  
IN HOLD CIRCUIT TO THIS RELAY.

### NO. 3 BUMPER RELAY

IS ENERGIZED BY LEFT BOTTOM JET BUMPER SWITCH.

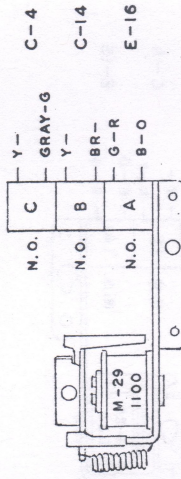

ENERGIZES LEFT BOTTOM JET BUMPER COIL.  
ENERGIZES 10 POINT OR 100 POINT RELAY.  
IN HOLD CIRCUIT TO THIS RELAY.

### NO. 4 BUMPER RELAY

IS ENERGIZED BY RIGHT BOTTOM JET BUMPER SWITCH.

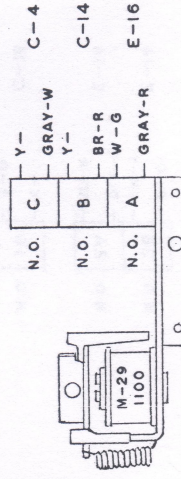

ENERGIZES RIGHT BOTTOM JET BUMPER COIL.  
ENERGIZES 10 POINT OR 100 POINT RELAY.  
IN HOLD CIRCUIT TO THIS RELAY.

### "E" RELAY

IS ENERGIZED BY WIPER FINGER ON MAN ADVANCE UNIT. (EVERY 10TH STEP).

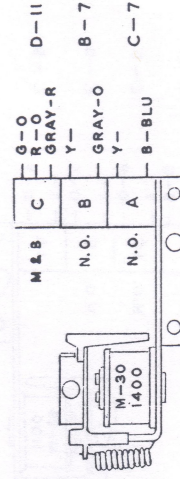

IN CIRCUIT TO EXTRA BALL UNIT STEP-UP COIL.  
TO RIGHT SIDE ROLLOVER "SPECIAL" LITE.  
TO "E" LITE.

### MAN ADVANCE RELAY

IS ENERGIZED BY A, B, C, D, OR E ROLLOVERS, WHEN LIT.

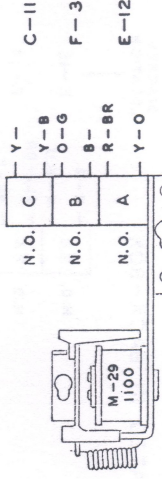

IN SERIES WITH SWITCH C ON "E RELAY".  
RUNS SCORE MOTOR.  
IN HOLD CIRCUIT TO THIS RELAY.



### 1000 POINT RELAY

IS ENERGIZED BY 5000 RELAY, 3000 RELAY, AND A AND E ROLLOVER SWITCHES AS INDICATED.

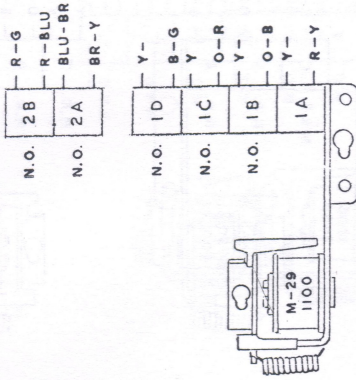

IN SERIES WITH SWITCH A ON KICKOUT RELAY.  
 IN HOLD CIRCUIT TO THIS RELAY.  
 PULSES CHIME COIL.  
 PULSES 10,000 POINT DRUM UNIT, THRU 9TH POSITION SWITCH ON 1000 POINT DRUM UNIT.  
 PULSES 1000 POINT DRUM UNIT.  
 ENERGIZES BALL INDEX RELAY.

### 100 POINT RELAY

IS ENERGIZED BY (4) BUMPER RELAYS, AND (6) TOP TARGETS AS INDICATED.

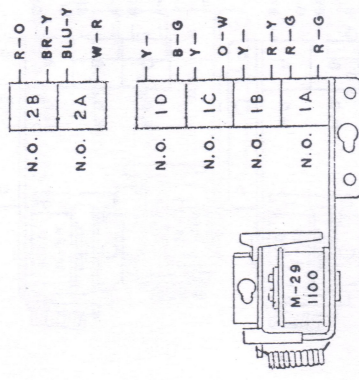

PULSES 1000 POINT RELAY, THRU 9TH POSITION SWITCH ON 100 POINT DRUM UNIT.  
 IN HOLD CIRCUIT TO THIS RELAY.  
 PULSES CHIME COIL.  
 PULSES 100 POINT DRUM UNIT.  
 ENERGIZES BALL INDEX RELAY.  
 IN SERIES WITH SWITCH A ON KICKOUT RELAY.

### 10 POINT RELAY

IS ENERGIZED BY STANDUP SWITCHES, KICKER SWITCHES AND (4) BUMPER RELAYS.

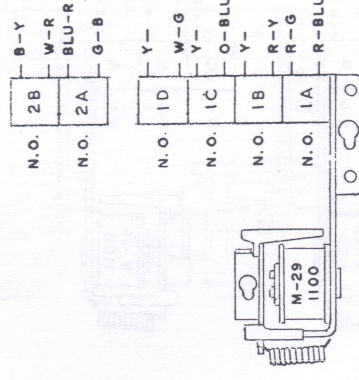

PULSES 100 POINT RELAY, THRU 9TH POSITION SWITCH ON 10 POINT DRUM UNIT.  
 IN HOLD CIRCUIT TO THIS RELAY.  
 PULSES SMALL BELL COIL.  
 PULSES 10 POINT DRUM UNIT.  
 ENERGIZES BALL INDEX RELAY.  
 IN SERIES WITH SWITCH A ON KICKOUT RELAY.

### 100,000 RELAY

IS ENERGIZED BY 10,000 POINT DRUM UNIT E.O.S. SWITCH, THRU 10,000 POINT DRUM UNIT 9TH POSITION SWITCH.

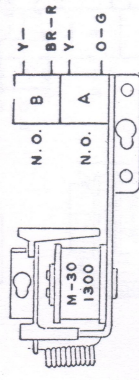

TO 100,000 LITE.  
 IN HOLD CIRCUIT TO THIS RELAY.