

Instruction Manual

for

JACK POT

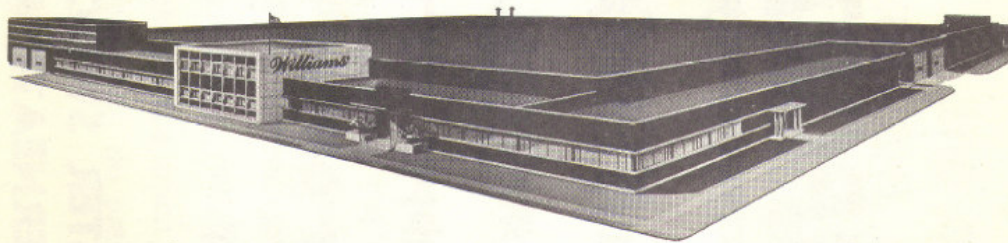

Williams® ELECTRONICS, INC.
SUBSIDIARY OF THE SEEBURG CORPORATION

3401 N. California Ave.
Phone 267-2240

Chicago, Ill. 60618, U.S.A.
Cable Address: Wilcoin

IMPORTANT NOTICE

**KINDLY INFORM LOCATIONS THAT THEY
CAN TURN DISPLAY LIGHTS ON BY PRESSING
LEFT FLIPPER BUTTON. MACHINE CAN STILL
BE SHUT OFF BY TAPPING BOTTOM OF
CABINET.**

**MASTER SWITCH (ON-OFF) IS LOCATED
UNDERNEATH FRONT PART OF CABINET.**

CAUTION!

The playboard on this machine has an improved finish with excellent wearing properties. Do not under any circumstances clean the board with water, water soap solutions or harsh abrasives. Avoid such things as steel wool, kitchen cleansers or abrasive hand soap. Water will weaken the adhering of the paint to the board and abrasives shorten the board life by many thousand plays. A wax base cleaner with negligible abrasive qualities used lightly, but frequently, will extend the board life to its full capabilities.

SERVICEMAN TO REMOVE BACKGLASS:

- **WITH BACK DOOR REMOVED, PULL BACK ON BRACKETS AT INSIDE TOP OF LITE BOX.**
- **FROM THE FRONT OF GAME, LIFT GLASS UP AND OUT.**

ALTERNATOR UNIT

LOCATED ON MECHANISM PANEL .

USED IN CONJUNCTION WITH 5¢ RELAY FOR "2 COINS-1 PLAY" FEATURE.

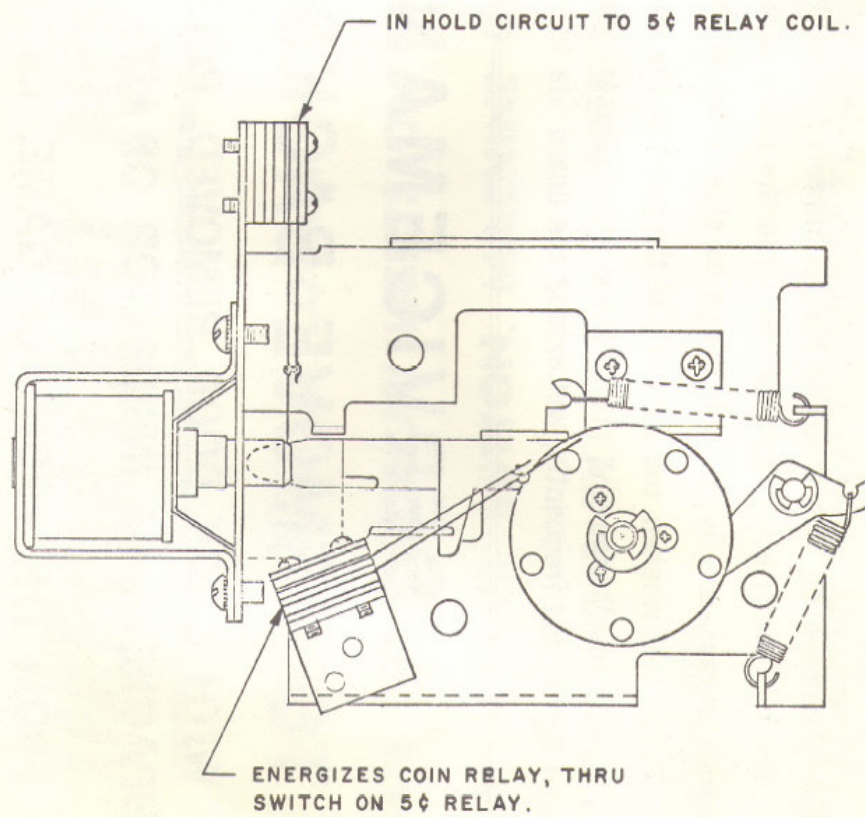

INSTRUCTIONS FOR COIN TRIP SWITCH ADJUSTMENT

WIRE SHOULD BE IN CONTACT WITH END OF CRESCENT OPENING WHEN BLADE ADJUSTMENT IS MADE.

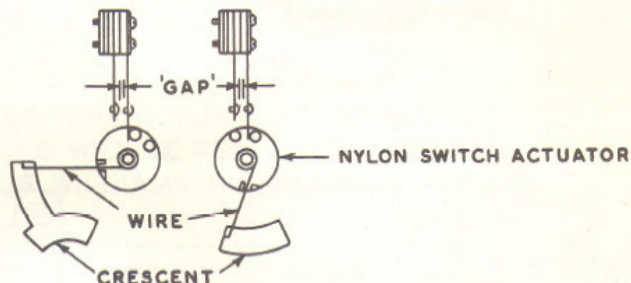

Long blade should be in contact with nylon switch actuator and have a maximum overtravel of $1/32$.

or

Using a gram gauge, tension of long blade should not exceed 10 grams.

SWITCH ADJUSTMENT

1. For small coins, such as dimes, adjust short blade so that the 'gap' between the silver contacts is .045 to .055.
2. For larger & heavier coins the 'gap' should be .045 to .060.
3. Do not adjust 'gap' closer than .040.

POWER TRANSFORMER:

LOCATED ON MECHANISM PANEL, IT IS EQUIPPED WITH A SECONDARY TAP. IF YOUR GAME IS ON LOCATION WITH EXTREMELY LOW LINE VOLTAGE, REMOVE LEAD FROM LUG MARKED 24 VOLTS AND SOLDER TO ALTERNATE LUG MARKED "HIGH". THIS WILL BOOST SECONDARY VOLTAGE APPROXIMATELY 2-3 VOLTS.

LEG LEVELERS:

ARE PROVIDED FOR TWO PURPOSES - 1ST TO LEVEL GAME ON LOCATION, 2ND TO INCREASE PITCH FOR GAME PERCENTAGING. IF IT IS DESIRED TO SPEED UP PLAY AND DECREASE SCORES, RAISE REAR LEG LEVELERS TO INCREASE PITCH.

INSTRUCTIONS FOR ALTERING COIN CHUTES EQUIPPED WITH A FLIP-OVER DEVICE.

FOR 1 COIN - FOR 1 PLAY

OR 2 COINS - FOR 1 PLAY

FIGURE 1

FIGURE 2

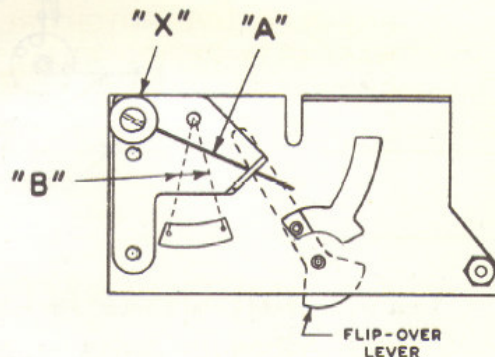
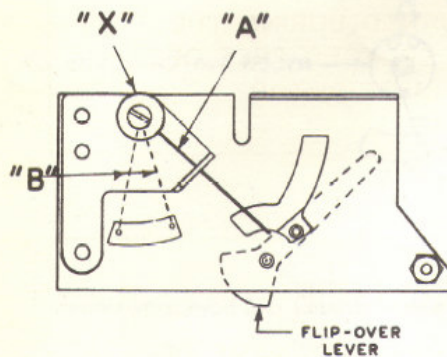

1 COIN - FOR 1 PLAY (FIGURE 1):

Wire form "A" should be in position as shown in Figure 1. Flip-over lever should rebound from wire form "A" and return to position shown in Figure 1 everytime a coin is inserted. All coins pass over the coin trip switch wire "B".

2 COINS - FOR 1 PLAY (FIGURE 2):

Wire form "A" should be in position as shown in Figure 2 (see note). Flip-over lever should alternate from side to side. 1st coin should go to cash box without actuating coin trip switch wire "B", 2nd coin should pass the coin trip switch wire "B" and returns flip-over to position as shown in Figure 2.

NOTE:

To change from 1 coin play to 2 coin play or vice versa - loosen screw "X" and move screw, bushing & wire form "A" to position as required - shown in Figure 1 position as required - shown in Figure 1 or Figure 2.

When using 1 coin for 1 play, wire form "A" should not under any circumstances be allowed to enter the "Banana" slot and cause binding of flip-over lever.

WARRANTY

THE MOTORS IN ALL NEW WILLIAMS PRODUCTS ARE UN-CONDITIONALLY GUARANTEED FOR 6 MONTHS FROM DATE OF PURCHASE.

ANY DEFECTIVE MOTORS RETURNED DURING THE WARRANTY PERIOD WILL BE REPLACED FREE OF CHARGE BY YOUR WILLIAMS DISTRIBUTOR.

IMPORTANT NOTICE

WHEN ORDERING PARTS ALWAYS SPECIFY NAME OF UNIT, GAME AND SERIAL NUMBER, IN ADDITION TO A CLEAR DESCRIPTION OF THE PART AND PART NUMBER IF POSSIBLE.

UNIT NAME	CONTACT DISC	WIPER ASSEMBLY	RATCHET GEAR ASSEMBLY	MOTORS
REPLAY	-----	-----	A-6400	
BALL COUNT	C-6932	C-6520	A-6402-5	
NO. MATCH	C-6879	C-6520	A-6401	
PLAYER	C-6417	C-6521	A-6405-3	
COIN	C-6896	C-6520	A-6402-3	
10 POINT	B-7253	A-6294	3C-7272	14A-7805 (60 CYCLE) SCORE MOTOR
100 POINT	-----	-----	3C-7272	
1000 POINT	B-7253	A-6294	3C-7272	14A-7806 (60 CYCLE) SCORE MOTOR
10000 POINT	B-7253	A-6294	3C-7272	
LEFT REEL	B-7253	A-7394	3C-7272	
CENTER REEL	B-7253	A-7394	3C-7272	
RIGHT REEL	B-7253	A-6294	3C-7272	

COIL CHART

NOTICE:

THIS GAME OPERATES ON 24 VOLTS. WHEN ORDERING REPLACEMENT TRANSFORMERS, MOTORS, COILS OR METERS ... MAKE SURE TO SPECIFY CORRECT PART NUMBER.

<u>NUMBER</u>	<u>DESCRIPTION</u>	<u>LOCATION</u>
14 A 7871	SCORE MOTOR - 50-60 CYCLE	MECH. PANEL
15 A 6771	TRANSFORMER - 60 CYCLE	MECH. PANEL
15 A 6782-1	TRANSFORMER - 50 CYCLE	MECH. PANEL
B 6396	PLAY METER (Coil XM 27-675)	MECH. PANEL
<u>SOLENOID COILS</u>		
A 22-550	MATCH UNIT STEP UP	INSERT
	BALL RELEASE COIL	PLAYFIELD
	PLAYER UNIT STEP UP	INSERT
	COIN UNIT STEP UP	MECH. PANEL
A 23-600	BALL COUNT UNIT STEP UP	MECH. PANEL
	REPLAY UNIT STEP UP	INSERT
A2-23-750	LARGE BELL KNOCKER	CABINET CABINET
B 26-800	PLAYER UNIT RESET	INSERT
	REPLAY UNIT RESET	INSERT
	BALL COUNT UNIT RESET	MECH. PANEL
	COIN UNIT RESET	MECH. PANEL
	ALTERNATOR UNIT	MECH. PANEL
B1-26-800	SCORE DRUM UNIT ... (16 req'd.)	INSERT
	REELS ... (3 req'd.)	PLAYFIELD
FL 21-375/28-400	FLIPPER COILS ... (2 req'd.)	PLAYFIELD
G 22-550	JET BUMPER COILS ... (5 req'd.)	PLAYFIELD
G 23-750	KICKER COILS ... (2 req'd.)	PLAYFIELD
	DISAPPEARING POST (LATCH COIL)	PLAYFIELD
	EJECT COILS ... (3 req'd.)	PLAYFIELD
<u>RELAY COILS</u>		
M 1-31-1500	COIN LOCKOUT	DOOR
M 29-1000	DISAPPEARING POST (TRIP)	PLAYFIELD
	1st & 2nd SCORE RESET RELAY	INSERT
	3rd & 4th SCORE RESET RELAY	INSERT
	GAME OVER RELAY	MECH. PANEL
M 29-1100	10 POINT RELAY	INSERT
	100 POINT RELAY	INSERT
	1,000 POINT RELAY	INSERT
	5¢ RELAY	MECH. PANEL
	10¢ RELAY	MECH. PANEL
	25¢ RELAY	MECH. PANEL
	L - ADVANCE RELAY	PLAYFIELD
	R - ADVANCE RELAY	PLAYFIELD
	POST RELAY	PLAYFIELD
	CENTER ADVANCE RELAY	PLAYFIELD
	NO. 1 BUMPER RELAY	PLAYFIELD
	NO. 2 BUMPER RELAY	PLAYFIELD
	NO. 3 BUMPER RELAY	PLAYFIELD
	NO. 4 BUMPER RELAY	PLAYFIELD
	NO. 5 BUMPER RELAY	PLAYFIELD
	R.O. RELAY	PLAYFIELD
M 30-1400	3,000 RELAY	PLAYFIELD
	4,000 RELAY	PLAYFIELD
	5,000 RELAY	PLAYFIELD
	10,000 RELAY	PLAYFIELD
	BAR RELAY	PLAYFIELD
Z 27-1000	PLAYER RESET RELAY	MECH. PANEL
	OUTHOLE RELAY	MECH. PANEL
	RESET RELAY	MECH. PANEL
	REPLAY RELAY	MECH. PANEL
	EJECT RELAY	MECH. PANEL
	COIN RELAY	MECH. PANEL
	GAME OVER RELAY	MECH. PANEL
Z 28-1150	LOCK RELAY	MECH. PANEL
	TILT RELAY	MECH. PANEL
	EXTRA BALL RELAY	MECH. PANEL
	BALL INDEX RELAY	MECH. PANEL
	ON YELLOW RELAY	PLAYFIELD
	ON GREEN RELAY	PLAYFIELD

POST ADJUSTMENT SHEET

TO MAKE GAME MORE "CONSERVATIVE" OR "LIBERAL" — MOVE POSTS $\frac{3}{16}$ " AS SHOWN IN SKETCH BELOW. SPOTTING HOLES ARE PROVIDED AND CAN BE SEEN ON REMOVAL OF POSTS.

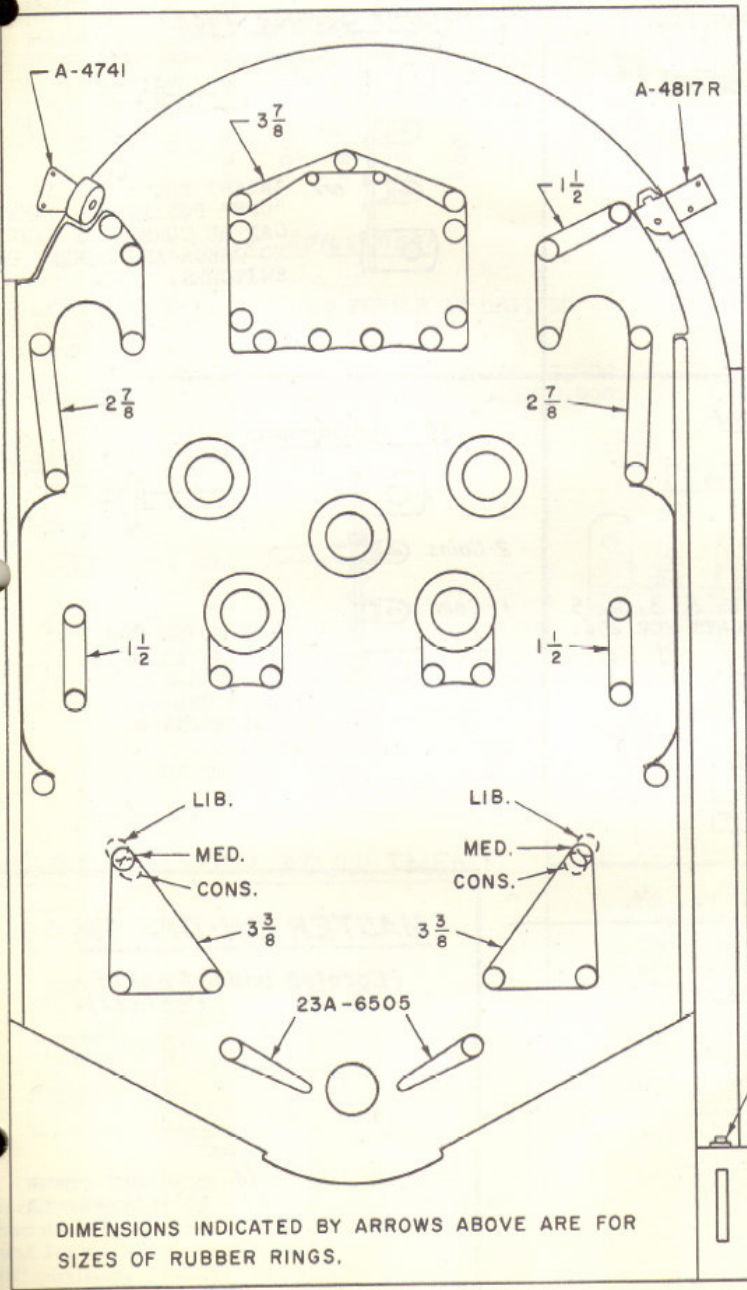

ABBREVIATIONS:
 CONS.-CONSERVATIVE
 LIB.-LIBERAL
 MED.-MEDIUM

RUBBER RING NUMBERS:
 23A-6300 5/16" I.D.
 23A-6304 1 1/2" I.D.
 23A-6307 2 7/8" I.D.
 23A-6308 3 3/8" I.D.
 23A-6309 3 7/8" I.D.
 23A-6505 FLIPPER R.R.

A-4741 REBOUND ASS'Y.
 A-4817R BALL GATE ASS'Y.

23A-6327 BALL SHOOTER RUBBER TIP

DIMENSIONS INDICATED BY ARROWS ABOVE ARE FOR SIZES OF RUBBER RINGS.

ADJUSTMENTS ON MECHANISM PANEL

10¢ Adjustment

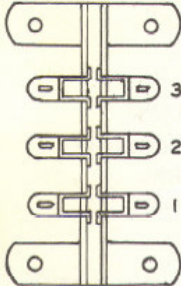

PROVIDES
1, 2 OR
3 PLAYS
FOR ONE
COIN.

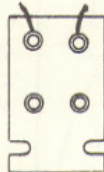

Motor Service Jack

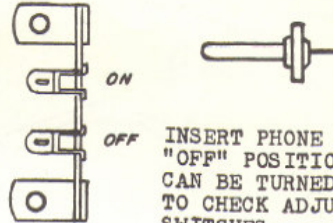

INSERT PHONE TIP IN
"OFF" POSITION - GAMS
CAN BE TURNED BY HAND
TO CHECK ADJUSTMENT OF
SWITCHES.

25¢ Adjustment

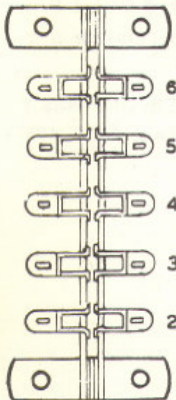

PROVIDES 2, 3, 4, 5
OR 6 PLAYS FOR 25¢.

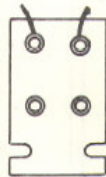

5¢ Adjustment

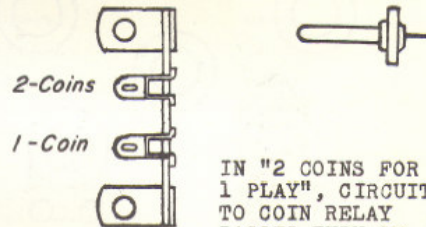

IN "2 COINS FOR
1 PLAY", CIRCUIT
TO COIN RELAY
PASSES THRU SW.
ON ALTERNATOR
UNIT.

SUGGESTED SCORE CARDS

REPLAY

5 BALL-----397-16
3 BALL-----397-8

EXTRA BALL

5 BALL-----397-4EB
3 BALL-----397-2EB

MASTER ON-OFF SW.

(Located under front of
Cabinet)

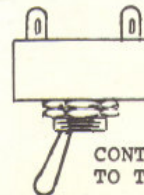

CONTROLS POWER
TO TRANSFORMER

ADJUSTMENTS IN BACKBOX

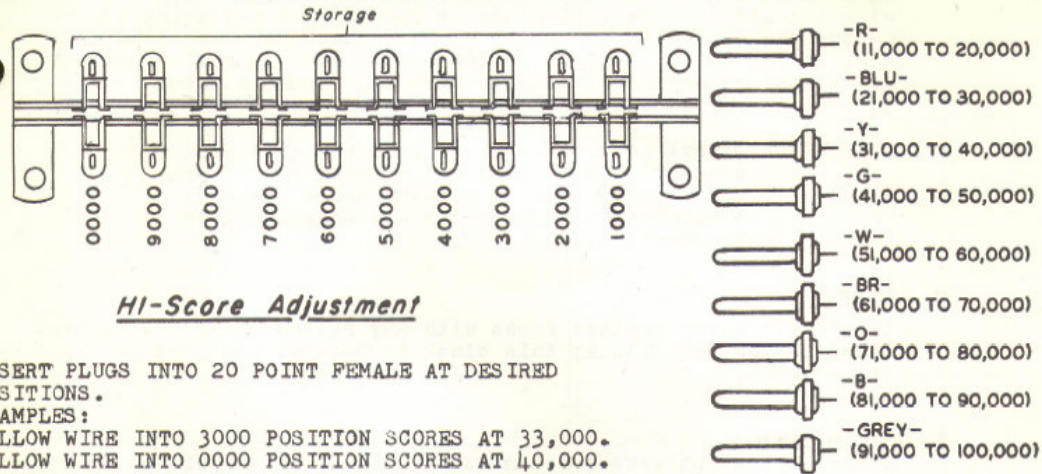

HI-Score Adjustment

INSERT PLUGS INTO 20 POINT FEMALE AT DESIRED POSITIONS.

EXAMPLES:

YELLOW WIRE INTO 3000 POSITION SCORES AT 33,000.
YELLOW WIRE INTO 0000 POSITION SCORES AT 40,000.

Extra Ball Jack Adj.

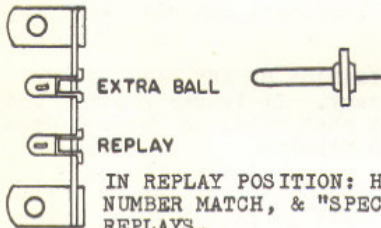

IN REPLAY POSITION: HI SCORES, NUMBER MATCH, & "SPECIAL" AWARD REPLAYS.

IN EXTRA BALL POSITION: HI-SCORES OR "SPECIAL" AWARD ONE EXTRA BALL.

FEATURE ADJ.

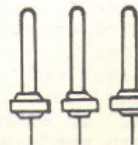
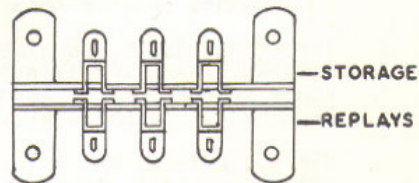

INSERT ONE PHONE TIP FOR EACH REPLAY REQUIRED WHEN MAKING A "SPECIAL". (SEE EXPLANATION OF EXTRA BALL ADJUSTMENT.)

NUMBER MATCH ADJUSTMENT

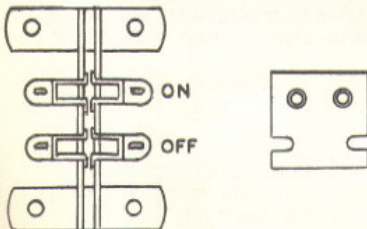

In 'ON' position, a number match lite will appear when game is over. To award replays, when number is matched, Extra Ball Adjustment Jack must be in 'Replay' position. In 'Off' position, Number Match is inoperative.

No. of Balls Adjustment

This switch changes 3 Ball to 5 Ball play, or vice versa.

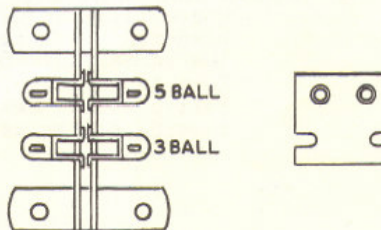

1. GENERAL

NEVER EXPERIMENT with any of the mechanism. Locate any trouble with the aid of Wiring Diagrams or Operating & Servicing Information supplied with the machine, then check for proper adjustment of the units involved before making any changes. Improper adjustment or make-shift repair will only cause serious damage to other parts of the machine or repeated failure of the part.

NOTE: Always look for a possible loose wire, bad connection at a plug and socket, broken or unhooked springs on step-up units, relays, etc., before adjustments are made or wires reconnected.

2. FUSES

IMPORTANT: Never replace fuses with any rating other than specified on the fuse block; this block is located adjacent to the transformer.

3. LUBRICATION

Over-lubrication causes far more trouble in coin operated equipment than under-lubrication. Practically all cases of poor contact on switches and wiper discs are due to oil or grease, or oil vapor, which forms a film or residue on the contacts and will not allow current to pass through. Excess lubricant may also seep into clutches causing them to slip.

IMPORTANT: NEVER USE VASELINE FOR LUBRICATION OF ANY PART OF THE MACHINE. Vaseline is not a true lubricant. It leaves a dirty and gummy residue and it becomes very thick when cold. A special Coin Machine Lubricant is supplied with each machine.

STEP-UP Levers, Ratchets, Cams, Shafts and other sliding or oscillating parts should be very lightly greased with special Coin Machine Lubricant (supplied with machine) not oftener than every six months. The bakelite discs (biscuits) on the Motor Units and Step-up Units will require lubrication with the special Coin Machine Lubricant only after the grease is completely evaporated (3 to 12 months, depending on climate) or when the film of grease becomes dirty. In either event, clean the parts thoroughly with a solvent, then apply an extremely thin coat of the special grease.

Solenoid Plungers should not have a lubricant of any kind. Should there be a sluggish tendency or if plungers are sticking, the parts should be cleaned with a solvent and flaked graphite applied on reassembly.

4. RELAY and SWITCH ADJUSTMENT

Where relay adjustments are called for, before bending blades, in all cases, on any machine, make certain that the screws holding the switch stacks are down very tightly. This is suggested because the plastic spacers in the switch stacks have occasionally shrunk by drying out, causing a poor adjustment.

BALL COUNT UNIT DISC

THIS UNIT RESETS AT THE START OF A NEW GAME, (DURING RESET CYCLE). IT ADVANCES ONE STEP EACH TIME THE LAST PLAYER COMPLETES HIS TURN.

View looking at WIPER FINGER side with WIPER in ZERO position.

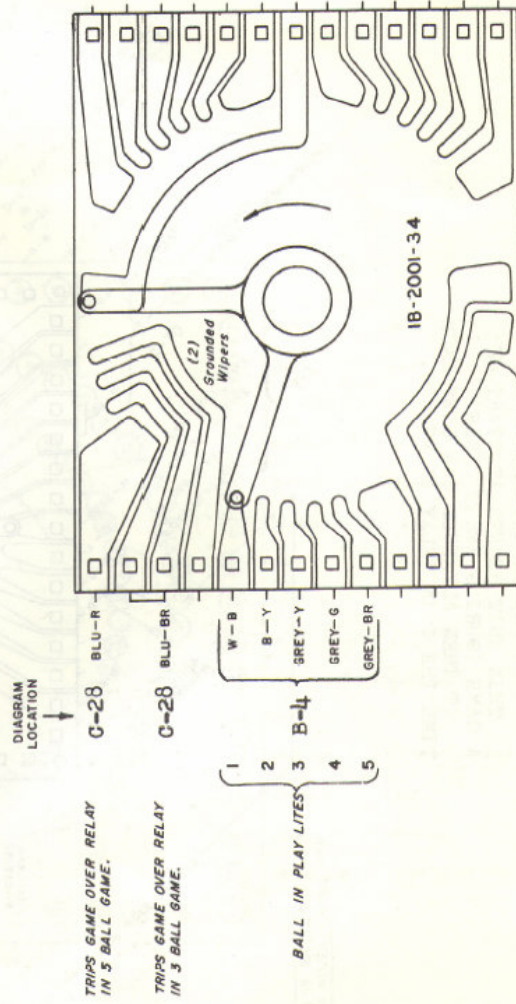

COIN S. U. DISC

THIS UNIT RESETS AT START OF A GAME (DURING RESET CYCLE). IT THEN ADVANCES ONE STEP EACH TIME THE COIN RELAY IS PULSED.

View looking at WIPER FINGER side with WIPER in RESET position

DIAGRAM LOCATION D-8

IN CIRCUIT TO BALL COUNT UNIT STEP UP COIL

2nd PLAYER NUMBER MATCH CIRCUIT

DIAGRAM LOCATION D-8

1st PLAYER NUMBER MATCH CIRCUIT

DIAGRAM LOCATION C-10

DIAGRAM LOCATION C-10

4th PLAYER NUMBER MATCH CIRCUIT

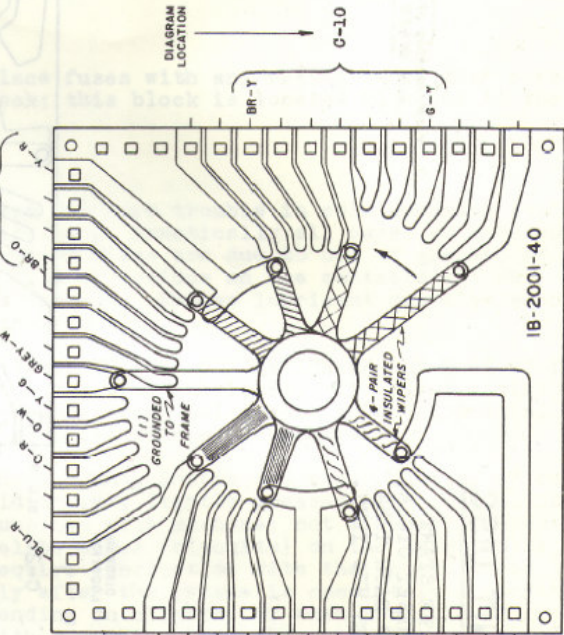

No. MATCH UNIT

THIS UNIT ADVANCES ONE STEP EACH TIME THE TEN POINT RELAY IS PULSED.

View looking at
WIPER FINGER side

IN NO. MATCH CIRCUIT,
THESE WIRES COME FROM
THE 1 PT. D.U. DISC OF
ALL 4 PLAYERS.

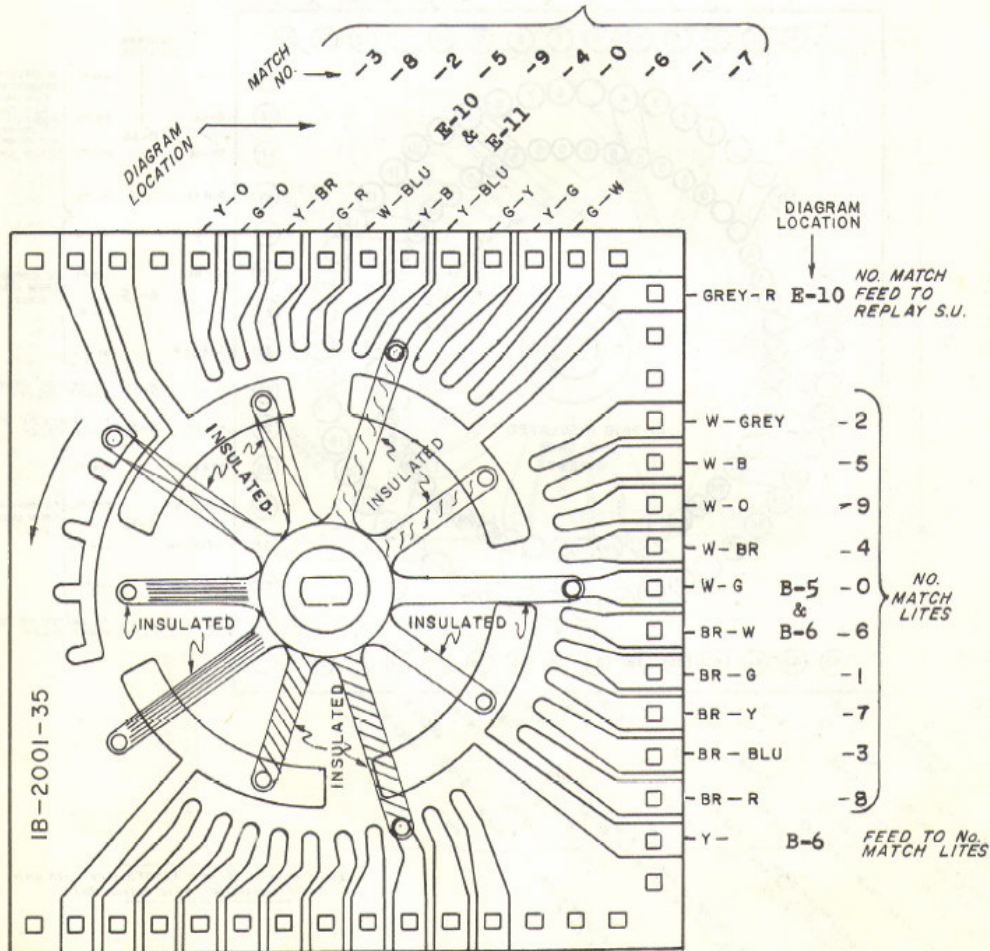

RELAYS & SWITCHES LOCATED ON MECHANISM PANEL

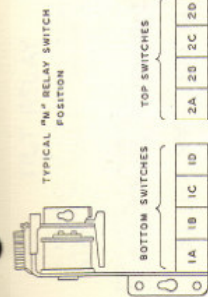

EJECT RELAY

IS ENERGIZED BY (3) EJECT FOOTER SWITCHES, THRU INDEX CAM SWITCH D.

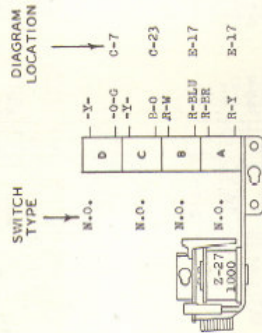

RUNS SCORE MOTOR

IN CIRCUIT TO REPLAY UNIT S.U., THRU SPECIAL RELAY.

PULSES EJECT COILS AT SCORE MOTOR CAM SW. 40.

HOLD CIRCUIT TO THIS RELAY, THRU CAM SWITCH 5A.

GAME OVER RELAY

INTERLOCK

LATCH COIL IS RELEASED BY SCORE MOTOR CAM SWITCH 11. THRU SWITCHES ON COIN RELAY AND RESET RELAY.
TRIP COIL IS ENERGIZED BY COIN RELAY, LOCK RELAY OR WIPER ON BALL COUNT UNIT.

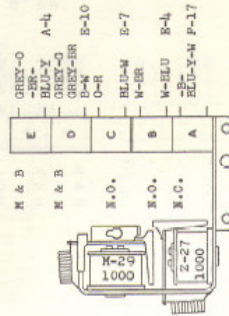

OPENS TO PLAYER UP LITES AND CLOSSES TO B0. MATCH LITES AND GAME-OVER LITE.

OPENS IN HI-SCORE CIRCUIT AND CLOSSES IN NO. MATCH CIRCUIT.

ENERGIZES RESET RELAY, THRU SWITCH D OR COIN RELAY.

IN CIRCUIT TO REPLAY RELAY.

OPENS ALL CIRCUITS TO PLAYFIELD SWITCHES.

REPLAY RELAY

IS ENERGIZED BY REPLAY BUTTON SWITCH, THRU REPLAY UNIT ZERO SWITCH.

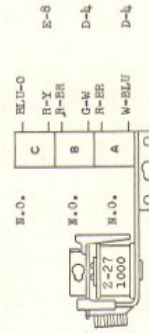

ENERGIZES REPLAY UNIT RESET COIL AT CAM SWITCH 1D.

ENERGIZES COIN RELAY.

IN HOLD CIRCUIT TO THIS RELAY.

COIN RELAY

IS ENERGIZED BY REPLAY RELAY OR COIN SWITCH.

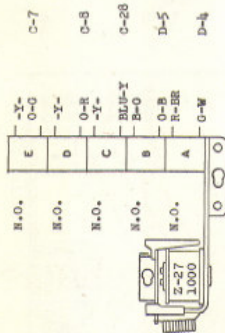

RUNS SCORE MOTOR
 IN SERIES WITH SWITCH C ON GAME-OVER RELAY (TRIP COIL).
 IN CIRCUIT TO GAME-OVER RELAY (TRIP COIL).
 ENERGIZES LOCK RELAY
 IN HOLD CIRCUIT TO THIS RELAY

RESET RELAY

IS ENERGIZED BY SWITCH D ON COIN RELAY.

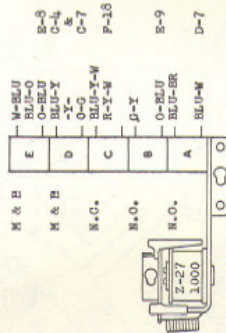

OPENS IN CIRCUIT TO COIN UNIT S.U. AND CLOSSES TO COIN UNIT RESET AND GAME-OVER RELAY (LATCH COIL).
 OPENS IN CIRCUIT TO REPLAY RELAY AND CLOSSES TO RUN SCORE MOTOR.
 IN SERIES WITH SWITCH A ON GAME-OVER RELAY.
 IN CIRCUIT TO PLAYER UNIT RESET COIL.
 IN HOLD CIRCUIT TO THIS RELAY.

EXTRA BALL RELAY

IS ENERGIZED BY SWITCH A ON SERIAL RELAY, AND BY HI-SCORE CIRCUIT--THRU "REPLAY-EXTRA BALL" ADJUSTMENT JACK.

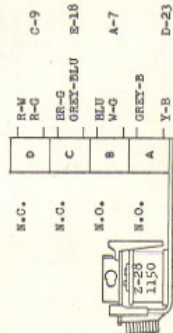

IN SERIES WITH SWITCH C ON BALL INDEX RELAY.
 IN CIRCUIT TO BALL INDEX RELAY, THRU SWITCH ON 10FT. 100 FT. OR 1000 FT. RELAY.
 TO "SHOOT AGAIN" LITES.
 IN HOLD CIRCUIT TO THIS RELAY.

TILT RELAY

IS ENERGIZED BY FLUMBER BOB TILT, BALL ROLL-DOWN TILT OR PLAYFIELD VIBRATION TILT SWITCH.

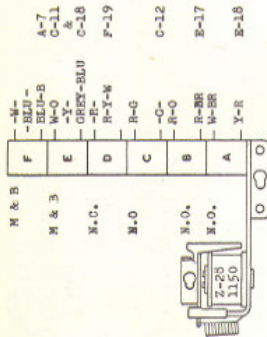

OPENS IN CIRCUIT TO PLAYFIELD LITES AND CLOSES TO TILT LIGHT.
 OPENS IN HI-SCORE CIRCUIT TO REPLAY S.U. AND CLOSES TO BALL INDEX RELAY.
 OPENS CIRCUIT TO ALL PLAYFIELD SWITCHES.
 IN CIRCUIT TO LEFT REEL ON PLAYFIELD.
 ENERGIZES POST RELAY.
 IN HOLD CIRCUIT TO THIS RELAY.

OUTHOLE RELAY

IS ENERGIZED BY OUTHOLE SWITCH AND SCORE MOTOR INDEX CAN SWITCH D.

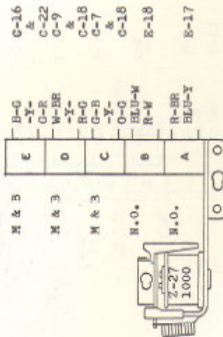

OPENS IN HOLD CIRCUIT TO "ON YELLOW" & "ON GREEN" RELAYS, CLOSES TO DOWN POST COIL.
 OPENS CIRCUIT TO TILT. RELAY AND CLOSES IN SERIES WITH SWITCH D ON EXTRA BALL RELAY.
 OPENS IN HOLD CIRCUIT TO BALL INDEX RELAY AND CLOSES TO RUB SCORE MOTOR.
 ENERGIZES BALL RELEASE COIL AT CAN SWITCH 4C.
 IN HOLD CIRCUIT TO THIS RELAY.

PLAYER RESET RELAY

IS ENERGIZED BY BALL COUNT UNIT END-UP-STROKE SWITCH. IT THEN HOLDS IN THRU INDEX CAN SWITCH B.

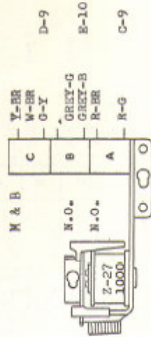

OPENS IN CIRCUIT TO PLAYER UNIT S.U. COIL AND CLOSES TO PLAYER UNIT RESET COIL.
 IN NO. MATCH CIRCUIT TO REPLAY S.U.
 HOLD CIRCUIT TO THIS RELAY, THRU INDEX CAN SWITCH B.

LOCK RELAY

IS ENERGIZED BY LEFT FLIPPER SWITCH OR 5F, 10F, 25F OR COIN RELAYS.

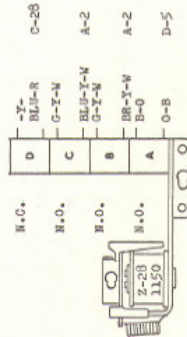

ENERGIZES GAME-OVER RELAY (TRIP COIL).
 6 VOLTS FROM TRANSFORMER TO LITES.
 6 VOLTS FROM TRANSFORMER TO LITES.
 HOLD CIRCUIT TO THIS RELAY, THRU CABINET BOTTOM KICKOFF SWITCH.

5¢ RELAY

IS ENERGIZED BY 5¢ COIN SWITCH. THIS RELAY IS USED ON GAMES WITH "2 COINS FOR 1 PLAY" FEATURE.

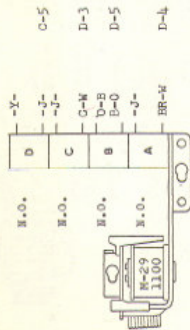

ENERGIZES ALTERNATOR UNIT COIL.
 ENERGIZES COIL RELAY, THRU SWITCH ON ALTERNATOR UNIT.
 ENERGIZES LOCK RELAY.
 IN HOLD CIRCUIT TO THIS RELAY, THRU END-OF-STROKE SWITCH ON ALTERNATOR UNIT.

BALL INDEX RELAY

IS ENERGIZED BY 10 POINT, 100 POINT OR 1000 POINT RELAY. THIS RELAY IS USED ON BALL RELAY. IT IS ALSO ENERGIZED BY TILT RELAY.

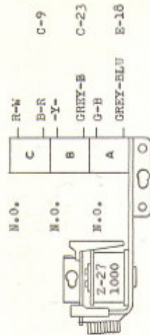

IN CIRCUIT TO BALL COUNT UNIT S.U.--ALSO IN SERIES WITH SWITCH C OF PLAYER RESET RELAY.
 IN HOLD CIRCUIT TO EXTRA BALL RELAY.
 IN HOLD CIRCUIT TO THIS RELAY.

10¢ RELAY

IS ENERGIZED BY 10¢ COIN SWITCH. IF 10¢ ADJUSTMENT JACK IS IN "2 PLAYS" OR "3 PLAYS" POSITION.

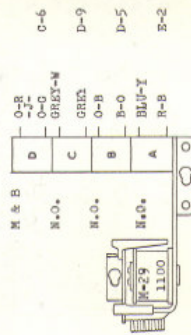

OPENS IN CIRCUIT TO KNOCKER COIL AND CLOSSES TO RUN SCORE MOTOR.
 PULSES REPLAY UNIT S.U. COIL, THRU IMPULSE CAM SWITCH D.
 ENERGIZES LOCK RELAY.
 IN HOLD CIRCUIT TO THIS RELAY.

25¢ RELAY

IS ENERGIZED BY 25¢ COIN SWITCH.

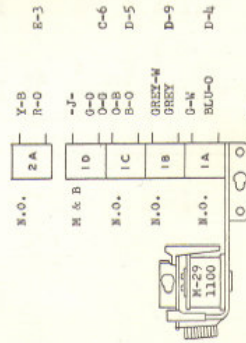

IN HOLD CIRCUIT TO THIS RELAY.
 OPENS IN CIRCUIT TO KNOCKER COIL AND CLOSSES TO RUN SCORE MOTOR.
 ENERGIZES LOCK RELAY.
 PULSES REPLAY UNIT S.U. COIL, THRU IMPULSE CAM SWITCH D.
 ENERGIZES COIL RELAY ON "6 PLAYS FOR 25¢".

POST RELAY

IS ENERGIZED BY LEFT RELAY OR REWINDER BUTTON AS INDICATED ON PLAYFIELD (DOWN POST?).

LOCATED ON PLAYFIELD

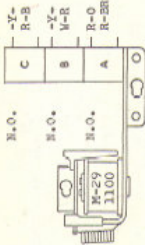

ENERGIZES "DOWN POST". COIL.
PULSES 100 POINT RELAY.
IN HOLD CIRCUIT TO THIS RELAY, THRU END-OF-STROKE SWITCH ON POST UNIT.

3000 RELAY

IS ENERGIZED BY LEFT, CENTER AND RIGHT REEL DISCS (ON PLAYFIELD). LINING UP THE PROPER SYMBOLS.
THE BAR RELAY, WHEN ENERGIZED, COMPLETES CIRCUIT THRU LEFT AND CENTER REEL DISCS.

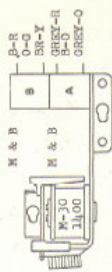

OPENS IN CIRCUIT TO "500" LITE (REEL VALUE) AND CLOSSES TO 3000 LITE.
OPENS IN CIRCUIT TO 100 POINT RELAY AND CLOSSES TO 1000 POINT RELAY.

4000 RELAY

IS ENERGIZED BY LEFT, CENTER AND RIGHT REEL DISCS (ON PLAYFIELD). LINING UP THE PROPER SYMBOLS.
THE BAR RELAY, WHEN ENERGIZED, COMPLETES CIRCUIT THRU LEFT AND CENTER REEL DISCS.

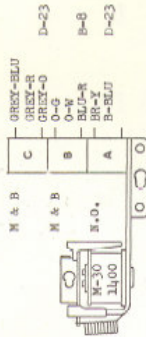

OPENS IN CIRCUIT TO 100 POINT RELAY AND CLOSSES TO 1000 POINT RELAY.
OPENS IN SERIES CIRCUIT WITH SWITCH B ON 3000 RELAY AND CLOSSES TO "4,000" LITE (REEL VALUE).
IN CIRCUIT TO PULSE 1000 RELAY, THRU CAM SWITCH UP.

5000 RELAY

IS ENERGIZED BY LEFT, CENTER AND RIGHT REEL DISCS (ON PLAYFIELD). LINING UP THE PROPER SYMBOLS.
THE BAR RELAY, WHEN ENERGIZED, COMPLETES CIRCUIT THRU LEFT AND CENTER REEL DISCS.

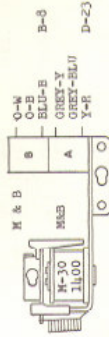

OPENS IN SERIES CIRCUIT WITH SWITCH B ON 1000 RELAY AND CLOSSES TO "5000" LITE (REEL VALUE).
OPENS IN CIRCUIT TO 100 POINT RELAY AND CLOSSES TO 1000 POINT RELAY AND EXTRA BALL RELAY.

SPECIAL RELAY

IS ENERGIZED BY LEFT, CENTER AND RIGHT REEL DISCS (ON PLAYFIELD). LINING UP THE PROPER SYMBOLS.
THE BAR RELAY, WHEN ENERGIZED, COMPLETES CIRCUIT THRU LEFT AND CENTER REEL DISCS.

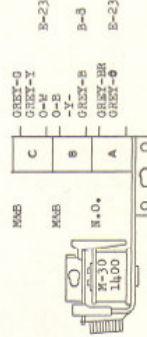

OPENS IN CIRCUIT TO PULSE 100 FT. RELAY AND CLOSSES TO 1000 FT. RELAY.
OPENS IN SERIES CIRCUIT WITH SWITCH B ON 5000 RELAY AND CLOSSES TO "SPECIAL" LITE (REEL VALUE).
SCORERS "SPECIAL", THRU REPEAT-EXTRA BALL ADJUSTMENT JACK

BAR RELAY

IS ENERGIZED BY WIPE ON FIGHT REEL DISC.

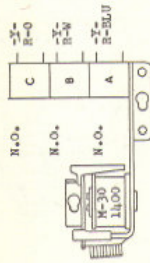

C-19 IN CIRCUIT TO 3000 RELAY, THRU CENTER AND LEFT REELS ON PLAYFIELD.
 C-19 IN CIRCUIT TO 4000 RELAY, THRU CENTER AND LEFT REELS ON PLAYFIELD.
 C-19 IN CIRCUIT TO 5000 RELAY, THRU CENTER AND LEFT REELS ON PLAYFIELD.

ROLL OVER RELAY

IS ENERGIZED BY TOP LEFT, TOP RIGHT, BOTTOM LEFT, OR BOTTOM RIGHT FOLLOVER SWITCHES.

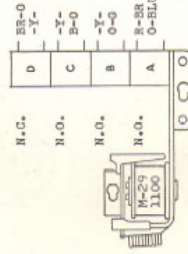

C-20 OPENS CIRCUITS TO (3) TOP ROLLOVER BUTTONS WHICH ADVANCE REELS ADVANCE REELS.
 C-22 IN PARALLEL WITH SWITCH C ON EJECT RELAY.
 C-7 RUNS SCORE MOTOR.
 B-19 IN HOLD CIRCUIT TO THIS RELAY.

NO. 5 BUMPER RELAY

IS ENERGIZED BY LEFT BOTTOM JET BUMPER SWITCH.

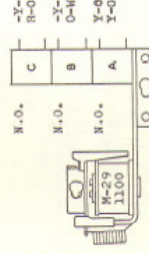

C-6 PULSES LEFT BOTTOM JET BUMPER COIL.
 C-24 IN SERIES WITH SWITCH E ON "ON GREEN" RELAY.
 D-27 IN HOLD CIRCUIT TO THIS RELAY.

NO. 4 BUMPER RELAY

IS ENERGIZED BY LEFT TOP JET BUMPER SWITCH.

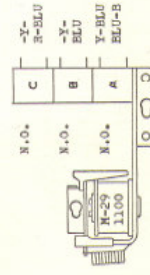

C-5 PULSES LEFT TOP JET BUMPER COIL.
 C-24 IN SERIES WITH SWITCH D ON "ON YELLOW" RELAY.
 D-27 IN HOLD CIRCUIT TO THIS RELAY.

NO. 3 BUMPER RELAY

IS ENERGIZED BY RIGHT TOP JET BUMPER SWITCH.

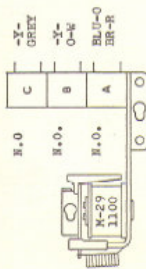

PULSES RIGHT TOP JET BUMPER COIL.
 IN PARALLEL WITH SWITCH B ON NO. 5 BUMPER RELAY.
 IN HOLD CIRCUIT TO THIS RELAY.

C-6
 C-24
 D-27

NO. 2 BUMPER RELAY

IS ENERGIZED BY CENTER JET BUMPER SWITCH.

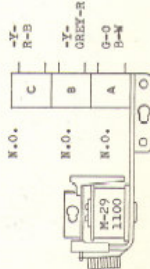

PULSES CENTER JET BUMPER COIL.
 IN SERIES WITH SWITCH C ON "ON YELLOW" RELAY.
 IN HOLD CIRCUIT TO THIS RELAY.

C-6
 C-24
 D-26

NO. 1 BUMPER RELAY

IS ENERGIZED BY RIGHT BOTTOM JET BUMPER SWITCH.

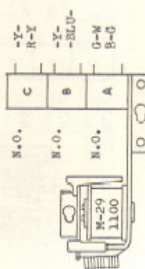

PULSES RIGHT BOTTOM JET BUMPER COIL.
 IN PARALLEL WITH SWITCH B ON NO. 4 BUMPER RELAY.
 IN HOLD CIRCUIT TO THIS RELAY.

C-6
 C-24
 D-26

ON YELLOW RELAY

IS ENERGIZED BY LEFT TOP EJECT POCKET SWITCH.

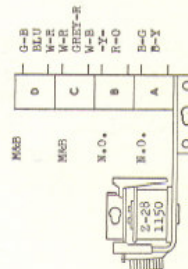

OPENS IN CIRCUIT TO 10 FT. RELAY AND CLOSURE TO 100 FT. RELAY.
 IN CIRCUIT TO 100 FT. RELAY OR 1000 FT. RELAY.
 TO LEFT TOP AND RIGHT BOTTOM JET BUMPER LINES.
 IN HOLD CIRCUIT TO THIS RELAY.

B-24
 C-24
 B-7
 B-22

ON GREEN RELAY

IS ENERGIZED BY RIGHT TOP EJECT POCKET SWITCH.

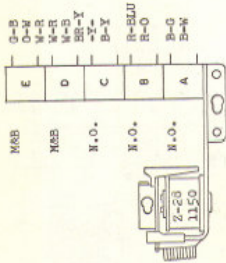

OPENS IN CIRCUIT TO 10 FT. RELAY AND CLOSSES TO 100 FT. RELAY.
 IN CIRCUIT TO 100 POINT RELAY OR 1000 POINT RELAY.
 TO LEFT BOTTOM AND RIGHT TOP JET BUMPER LINES.
 TO CENTER JET BUMPER LITE.
 IN HOLD CIRCUIT TO THIS RELAY.

E-24
 D-24
 B-8
 B-8
 B-22

RIGHT ADVANCE RELAY

IS ENERGIZED BY RIGHT TOP ROLLOVER BUTTON, RIGHT TOP TARGET OR RIGHT CENTER TARGET SWITCHES.

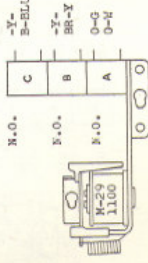

PULSES RIGHT REEL COIL.
 PULSES 1000 POINT RELAY.
 HOLD CIRCUIT TO THIS RELAY, THRU E.O.S. SWITCH ON RIGHT REEL UNIT.

C-13
 C-23
 E-22

CENTER ADVANCE RELAY

IS ENERGIZED BY CENTER TOP ROLLOVER BUTTON, CENTER TOP TARGET OR CENTER ROLLOVER OR RIGHT SIDE ROLLOVER SWITCHES.

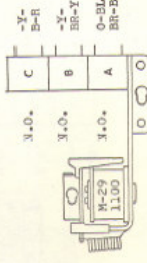

PULSES CENTER REEL COIL.
 PULSES 1000 POINT RELAY.
 HOLD CIRCUIT TO THIS RELAY, THRU E.O.S. SWITCH ON CENTER REEL UNIT.

C-13
 C-23
 E-21

LEFT ADVANCE RELAY

IS ENERGIZED BY LEFT TOP ROLLOVER BUTTON, LEFT TOP TARGET OR LEFT CENTER TARGET SWITCHES.

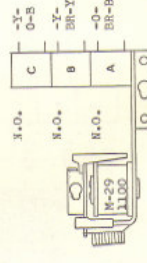

PULSES LEFT REEL COIL.
 PULSES 1000 POINT RELAY.
 HOLD CIRCUIT TO THIS RELAY, THRU E.O.S. SWITCH ON LEFT REEL UNIT.

C-12
 C-23
 E-21

10 POINT RELAY

IS PULSED BY NO. 1, 3, 4 AND 5 BUMPER RELAYS, AND BY KICKER SWITCHES AND STANDUP SWITCHES.

LOCATED IN BACKBOX

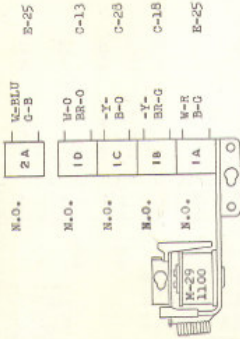

100 POINT RELAY

IS PULSED BY NO. 1, 2, 3, 4 OR 5 BUMPER RELAY AND BY KICKER SWITCHES AND STANDUP SWITCHES. RELAY OR BOLLVOYER RELAY ARE ENERGIZED.

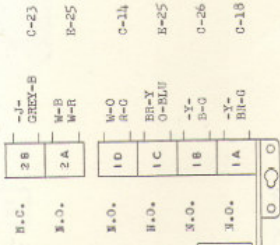

1000 POINT RELAY

IS PULSED BY 3000 RELAY, 1000 RELAY, 5000 RELAY, SPECIAL RELAY OR NO.2 BUMPER RELAY.

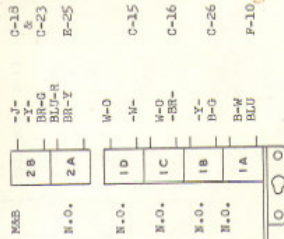

IN HOLD CIRCUIT TO THIS RELAY.

PULSES 10 POINT DRUM UNITS, THRU PLAYER UNIT DISC.

ENERGIZES NO. MATCH UNIT S.U. COIL.

IN SERIES WITH SWITCH C ON EXTRA BALL RELAY.

PULSES 100 POINT RELAY, THRU 9TH POSITION SWITCHES ON 10 POINT DRUM UNITS.

IN HOLD CIRCUIT TO EXTRA BALL RELAY.

IN HOLD CIRCUIT TO THIS RELAY.

PULSES 100 POINT DRUM UNITS, THRU PLAYER UNIT DISC.

PULSES 1000 POINT RELAY, THRU 9TH POSITION SWITCHES ON 100 POINT DRUM UNITS.

PULSES LARGE BELL COIL.

IN SERIES WITH SWITCH C ON EXTRA BALL RELAY.

OPENS IN HOLD CIRCUIT TO EXTRA BALL RELAY AND CLOSSES IN SERIES CIRCUIT WITH SWITCH C ON EXTRA BALL RELAY.

IN HOLD CIRCUIT TO THIS RELAY.

PULSES 1000 PT. DRUM UNITS, THRU PLAYER UNIT DISC.

PULSES 10,000 PT. DRUM UNITS, THRU 9TH POSITION SWITCHES ON 1000 POINT DRUM UNITS.

PULSES LARGE BELL COIL

IN HI-SCORE CIRCUIT TO REPLAY S.U. COIL.

1-2 RESET RELAY

IS PULSED BY IMPULSE CAM SWITCH E, THRU SWITCH A ON RESET RELAY.

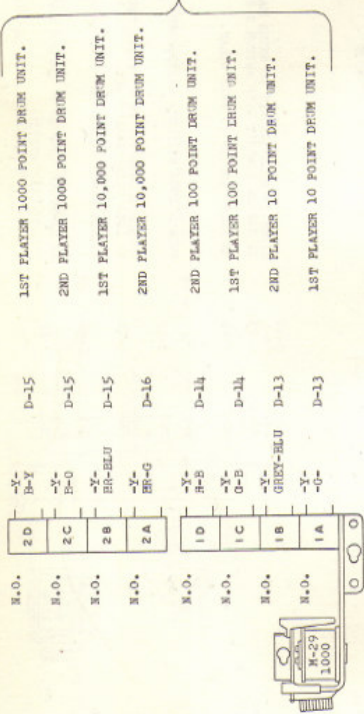

THESE DRUM UNITS ARE PULSED IN THE RESET CYCLE, THRU ZERO SWITCHES ON THE CORRESPONDING DRUM UNITS.

3-4 RESET RELAY

IS PULSED BY IMPULSE CAM SWITCH A, THRU SWITCH A ON RESET RELAY.

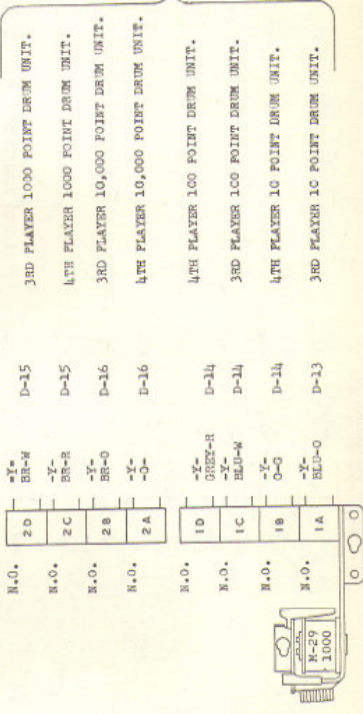

THESE DRUM UNITS ARE PULSED IN THE RESET CYCLE, THRU ZERO SWITCHES ON THE CORRESPONDING DRUM UNITS.

BALL EJECT CAM UNIT

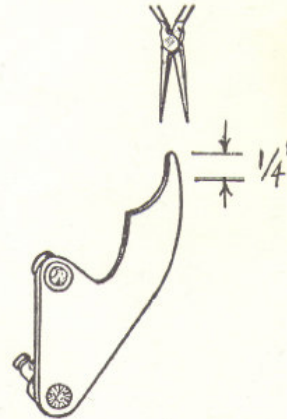
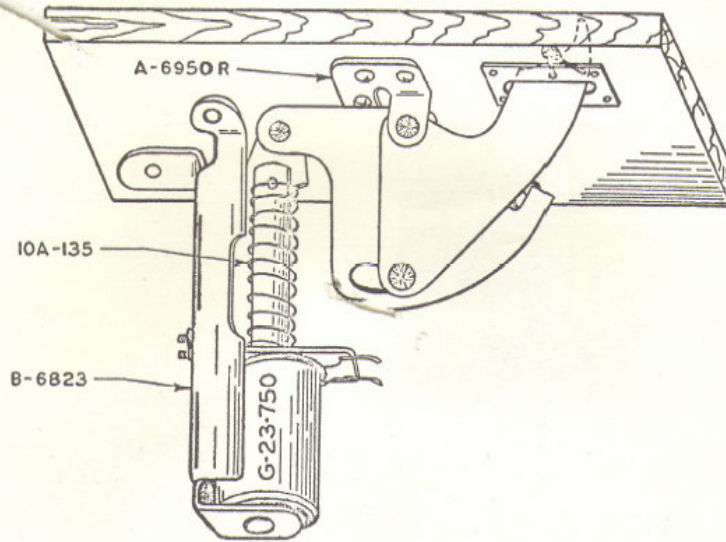

TO CHANGE DIRECTION OF BALL,
WHEN EJECTED, GRASP "BALL EJECT CAM"
WITH LONG-NOSED PLIERS (APPROXIMATELY
1/4") AND BEND SLIGHTLY.
BENDING TO THE LEFT WILL CHANGE
DIRECTION OF EJECTED BALL SLIGHTLY
TO THE RIGHT, AND VICE-VERSA.

CAUTION
IF BEND IS TOO GREAT, IT MAY
CAUSE A BIND WHEN "BALL EJECT CAM"
IS RESTING IN PART #3A-6015G-6.

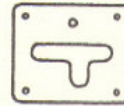

3A-6015G-6