

Instruction Manual for **SKYLAB** & **SPACELAB**



 **Williams**[®] ELECTRONICS
A DIVISION OF
THE SEEBURG CORPORATION OF DELAWARE

3401 N. California Ave.
(312) 267-2240

JUNE
1974

Chicago, Ill. 60618, U.S.A.
Cable Address: Wilcoin

"SKY LAB"

GAME OPERATES AS FOLLOWS

TOP ADVANCE ROLLOVER LANES, WHEN LIT, SCORE SPACELAB ADVANCE.

BOTTOM ADVANCE ROLLOVER LANES, WHEN LIT, SCORE SPACELAB ADVANCE.

MAKING S-K-Y-L-A-B SCORES TWO SPACELAB ADVANCES.

WHEN BALL LEAVES THE PLAYFIELD IT SCORES 3,000 TO 24,000, DEPENDING ON HOW FAR SPACELAB HAS BEEN ADVANCED. ON LAST BALL PLAYED, DOUBLE BONUS LITES AND GAME SCORES DOUBLE VALUE.

WHEN GAME IS SET IN CONSERVATIVE POSITION, SPACELAB SPECIALS LITE WHEN "B" IS MADE IN SPACELAB. WHEN GAME IS SET IN LIBERAL POSITION, SPACELAB SPECIALS LITE WHEN "E" IS MADE IN SPACELAB.

SPACELAB SPECIALS SCORE EITHER A REPLAY, EXTRA BALL OR 10,000 POINTS, DEPENDING ON PLAY ADJUSTMENT SETTING IN BACK BOX.

LOOPING FIVE BALLS INTO LIT SIDE SCORES A ROCKET SPECIAL. ROCKET SPECIAL SCORES AN EXTRA BALL OR 10,000 POINTS, DEPENDING ON PLAY ADJUSTMENT SETTING IN BACK BOX.

SILICON BRIDGE RECTIFIER

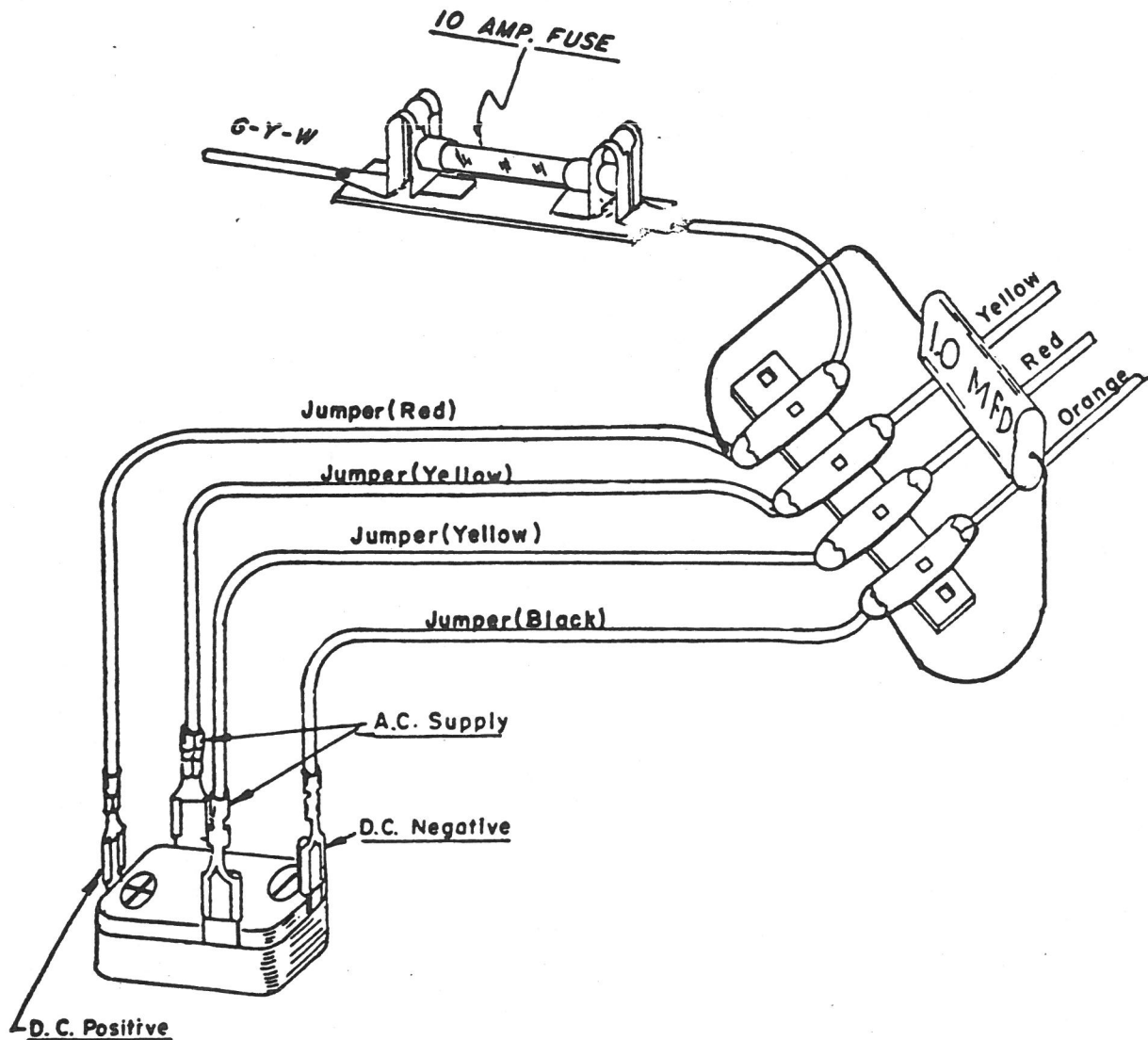

THE FUNCTION OF THE RECTIFIER AND CAPACITOR IS TO CONVERT THE ALTERNATING CURRENT (A.C.) TO DIRECT CURRENT (D.C.), SUPPLYING D.C. TO THE BUMPERS, KICKERS ETC.

THE BRIDGE RECTIFIER SHOULD PRACTICALLY NEVER NEED REPLACING, AS IT IS RATED WELL OVER THE VOLTAGE AND CURRENT REQUIREMENTS OF THE COMPONENTS IT SUPPLIES.

IF, HOWEVER, THE 15 AMP 24 VOLT FUSE ON THE MECHANISM PANEL OPENS, IT COULD BE DUE TO A FAULTY RECTIFIER. DISCONNECT THE A.C. INPUT TO RECTIFIER, REPLACE FUSE, AND RECHECK.

IF THE 10 AMP FUSE LOCATED NEXT TO THE RECTIFIER OPENS, CHECK ALL D.C. COMPONENTS I.E. BUMPERS, KICKERS ETC. FOR SHORTS.

"SKYLAB" — POST ADJUSTMENT SHEET

TO MAKE GAME MORE "CONSERVATIVE" OR "LIBERAL"—MOVE POST 3/16 AS SHOWN IN SKETCH BELOW. SPOTTING HOLES ARE PROVIDED AND CAN BE SEEN ON REMOVAL OF POST.

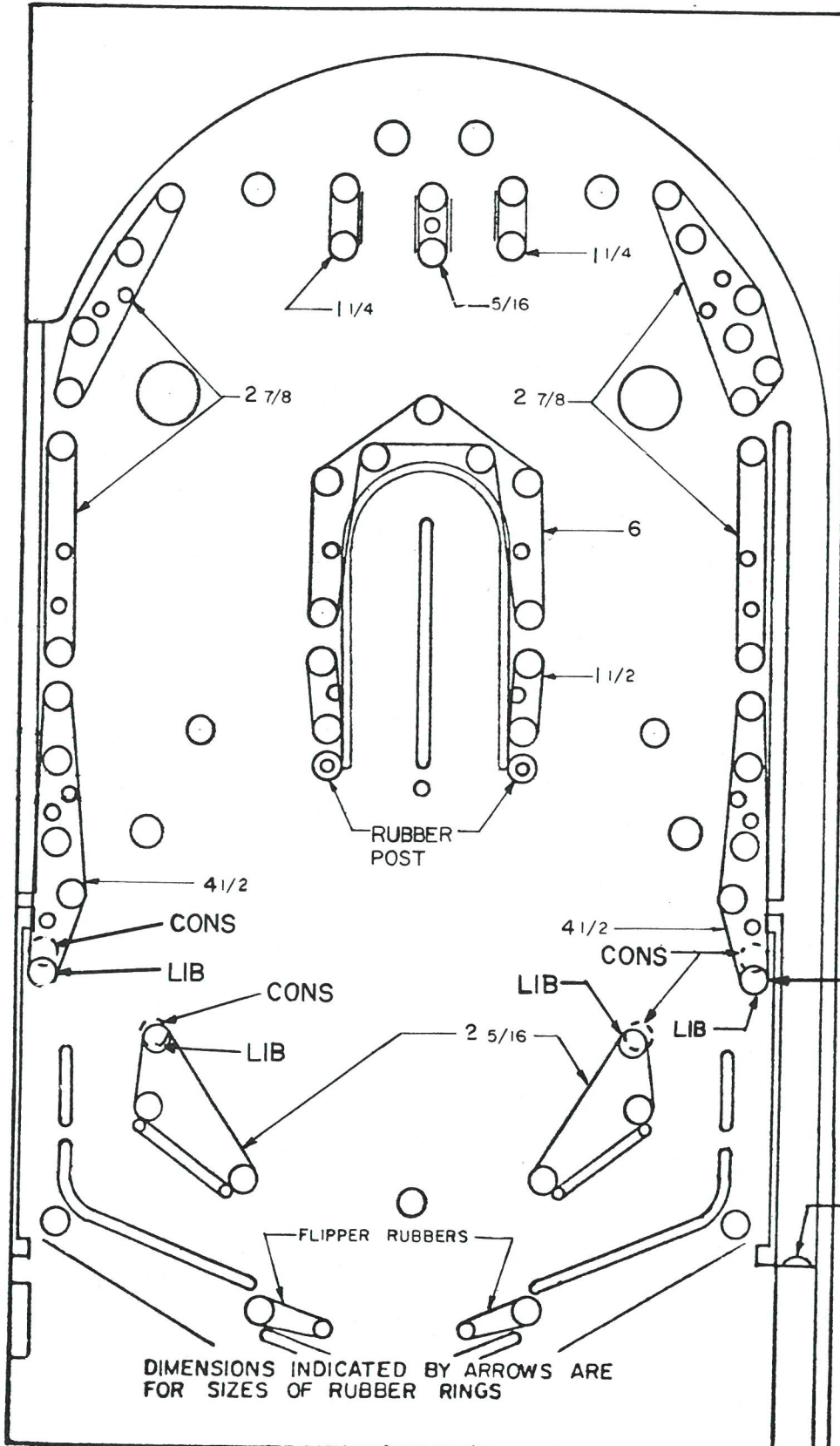

ABBREVIATIONS:

CONS - CONSERVATIVE
LIB — LIBERAL

RUBBER RING NUMBERS:

23A-6300	5/16 I.D.
23A-6303	1 1/4 I.D.
23A-6304	1 1/2 I.D.
23A-6306	2 5/16 I.D.
23A-6307	2 7/8 I.D.
23A-6429	6 I.D.
23A-6530	4 1/2 I.D.
23A-6519	— FLIPPER-RUBBERS
23A-6531	— RUBBER POST

IMPORTANT ADJUSTMENT

TO MAKE GAME MORE CONSERVATIVE THE FIRST ADJUSTMENT SHOULD BE MADE ON INDICATED BUMPER POST AND SAME BUMPER POST ON OPPOSITE SIDE. MOVE POSTS ONE OR TWO POSITIONS HIGHER. OTHER ADJUSTMENTS MAY NOT BE NECESSARY.

23A-6327 BALL SHOOTER RUBBER TIP

DIMENSIONS INDICATED BY ARROWS ARE FOR SIZES OF RUBBER RINGS

16A-443-PA.

I. GENERAL

NEVER EXPERIMENT with any of the mechanism. Locate any trouble with the aid of Wiring Diagrams or Operating & Servicing Information supplied with the machine, then check for proper adjustment of the units involved before making any changes. Improper adjustment or make-shift repair will only cause serious damage to other parts of the machine or repeated failure of the part.

NOTE: Always look for a possible loose wire, bad connection at a plug and socket, broken or unhooked springs on step-up units, relays, etc., before adjustments are made or wires reconnected.

2. FUSES

IMPORTANT: Never replace fuses with any rating other than specified on the fuse block; this block is located adjacent to the transformer.

3. LUBRICATION

Over-lubrication causes far more trouble in coin operated equipment than under-lubrication. Practically all cases of poor contact on switches and wiper discs are due to oil or grease, or oil vapor, which forms a film or residue on the contacts and will not allow current to pass through. Excess lubricant may also seep into clutches causing them to slip.

IMPORTANT: NEVER USE VASELINE FOR LUBRICATION OF ANY PART OF THE MACHINE. Vaseline is not a true lubricant. It leaves a dirty and gummy residue and it becomes very thick when cold. A special Coin Machine Lubricant is supplied with each machine.

STEP-UP Levers, Ratchets, Cams, Shafts and other sliding or oscillating parts should be very lightly greased with special Coin Machine Lubricant (supplied with machine) not oftener than every six months. The bakelite discs (biscuits) on the Motor Units and Step-up Units will require lubrication with the special Coin Machine Lubricant only after the grease is completely evaporated (3 to 12 months, depending on climate) or when the film of grease becomes dirty. In either event, clean the parts thoroughly with a solvent, then apply an extremely thin coat of the special grease.

Solenoid Plungers should not have a lubricant of any kind. Should there be a sluggish tendency or if plungers are sticking, the parts should be cleaned with a solvent and flaked graphite applied on reassembly.

SWITCH ADJUSTMENT

BEFORE ADJUSTING SWITCHES, MAKE CERTAIN THE SCREWS HOLDING THE SWITCH STACKS ARE DOWN TIGHTLY. BAKELITE SPACERS IN THE SWITCH STACKS, DUE TO EXCESSIVE MOISTURE, HAVE OCCASIONALLY SHRUNK BY DRYING OUT, CAUSING POOR ADJUSTMENT.

ADJUSTMENTS ON MECHANISM PANEL

10¢ Adjustment

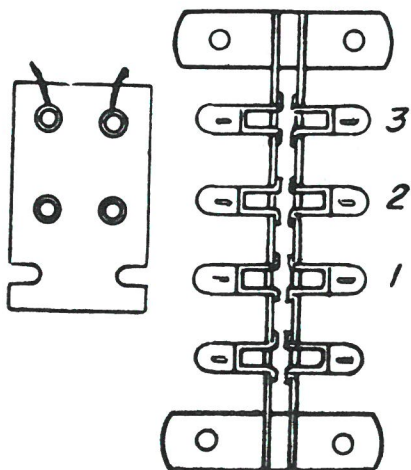

PROVIDES
1, 2 OR
3 PLAYS
FOR ONE
COIN.

5¢ Adjustment

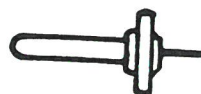
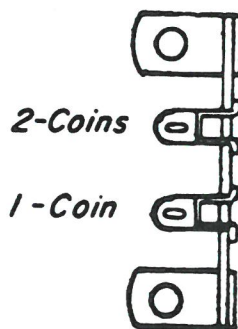

IN "2 COINS FOR
1 PLAY", CIRCUIT
TO COIN RELAY
PASSES THRU SW.
ON ALTERNATOR
UNIT.

25¢ Adjustment

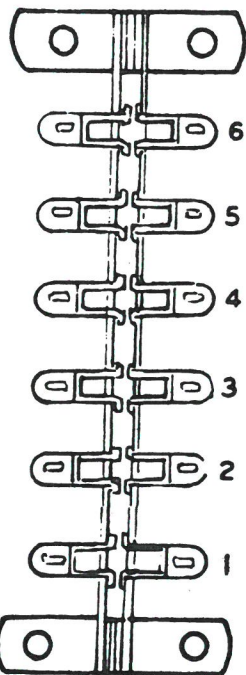

PROVIDES 1, 2, 3, 4, 5
OR 6 PLAYS FOR 25¢.

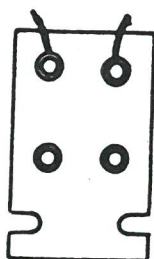

Motor Service Jack

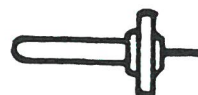
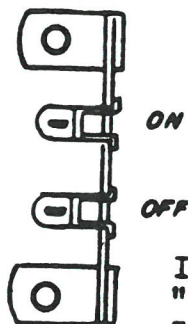

INSERT PHONE TIP IN
"OFF" POSITION - CAMS
CAN BE TURNED BY HAND
TO CHECK ADJUSTMENT OF
SWITCHES.

MASTER ON-OFF SW.

(Located under front of
Cabinet)

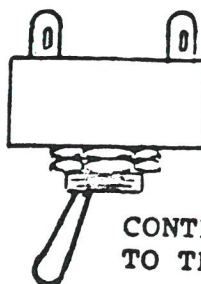

CONTROLS POWER
TO TRANSFORMER

ADJUSTMENTS IN BACKBOX

SCORE ADJUSTMENT

3-BALL GAME

Adjustment Range From
11,000 to 100,000 Only

PLUG IN RED WIRE FOR SCORES
11,000 to 20,000 - 3 BALL
111,000 to 120,000 - 5 BALL

PLUG IN BLUE WIRE FOR SCORES
21,000 to 30,000 - 3 BALL
121,000 to 130,000 - 5 BALL

PLUG IN YELLOW WIRE FOR SCORES
31,000 to 40,000 - 3 BALL
131,000 to 140,000 - 5 BALL

PLUG IN GREEN WIRE FOR SCORES
41,000 to 50,000 - 3 BALL
141,000 to 150,000 - 5 BALL

1000 6000

2000 7000

3000 8000

4000 9000

5000 0000

5-BALL GAME

Adjustment Range From
111,000 to 199,000 Only

PLUG IN WHITE WIRE FOR SCORES
51,000 to 60,000 - 3 BALL
151,000 to 160,000 - 5 BALL

PLUG IN BROWN WIRE FOR SCORES
61,000 to 70,000 - 3 BALL
161,000 to 170,000 - 5 BALL

PLUG IN ORANGE WIRE FOR SCORES
71,000 to 80,000 - 3 BALL
171,000 to 180,000 - 5 BALL

PLUG IN BLACK WIRE FOR SCORES
81,000 to 90,000 - 3 BALL
181,000 to 190,000 - 5 BALL

PLUG IN GRAY WIRE FOR SCORES
91,000 to 100,000 - 3 BALL
191,000 to 199,000 - 5 BALL

EXAMPLE:- Blue Wire into 1000 Position Scores 21,000 on 3 Ball Game, or 121,000 on 5 Ball Game.

434-5

No. of Balls Adjustment

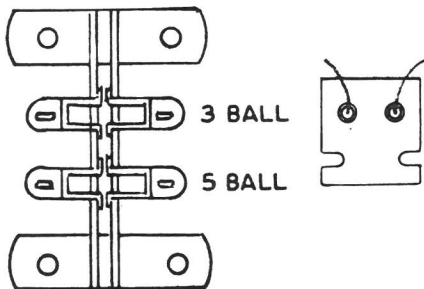

THIS JACK CHANGES 3 BALL
TO 5 BALL PLAY OR VICE VERSA.

NUMBER MATCH ADJUSTMENT

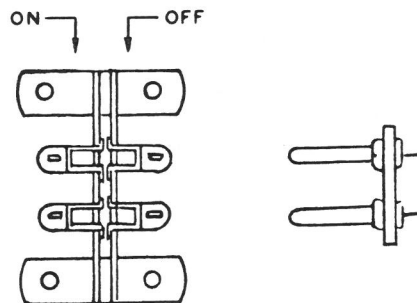

THIS ADJUSTMENT MUST BE IN "OFF" POSITION
IF "PLAY ADJUSTMENT JACK" IS IN POSITIONS
2 OR 3. IF "PLAY ADJUSTMENT JACK" IS IN
POSITION 1, THEN "NUMBER MATCH ADJUSTMENT"
CAN BE PUT IN "ON POSITION", IF SO DESIRED.
MATCHING LAST TWO DIGITS OF POINT SCORE TO
"MATCH LITE" WILL THEN SCORE A CREDIT.

PLAY ADJUSTMENT

JACK

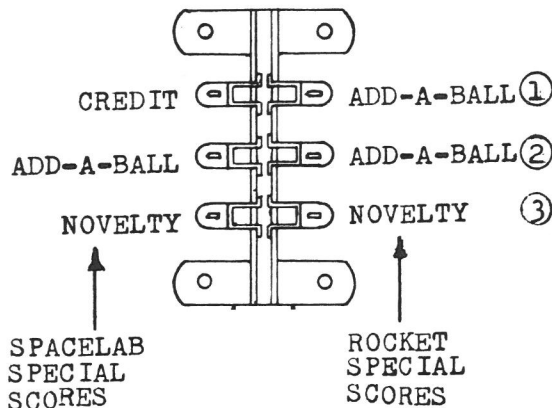

IN POSITION 1, 'SPACELAB SPECIAL'
ADVANCES CREDIT UNIT.
'ROCKET SPECIAL' ADVANCES BALL
COUNT UNIT.

IN POSITION 2, 'SPACELAB SPECIAL'
ADVANCES BALL COUNT UNIT.
'ROCKET SPECIAL' ADVANCES BALL
COUNT UNIT.

IN POSITION 3, 'SPACELAB SPECIAL'
ADVANCES 10,000 POINT DRUM UNIT.
'ROCKET SPECIAL' ADVANCES 10,000
POINT DRUM UNIT.

SPACELAB ADJ. JACK

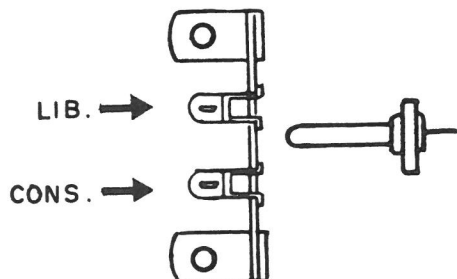

IN LIBERAL POSITION, SPACELAB RELAY WILL ENER-
GIZE WHEN ADVANCE UNIT STEPS UP TO LITE LETTER
"E" IN S-P-A-C-E-LAB.

IN CONSERVATIVE POSITION, SPACELAB RELAY WILL
ENERGIZE WHEN ADVANCE UNIT STEPS UP TO LITE
LETTER "B" IN S-P-A-C-E-L-A-B.

WARRANTY

THE MOTORS IN ALL NEW WILLIAMS PRODUCTS ARE UN-CONDITIONALLY GUARANTEED FOR 6 MONTHS FROM DATE OF PURCHASE.

ANY DEFECTIVE MOTORS RETURNED DURING THE WARRANTY PERIOD WILL BE REPLACED FREE OF CHARGE BY YOUR WILLIAMS DISTRIBUTOR.

IMPORTANT NOTICE

WHEN ORDERING PARTS ALWAYS SPECIFY NAME OF UNIT, GAME AND SERIAL NUMBER, IN ADDITION TO A CLEAR DESCRIPTION OF THE PART AND PART NUMBER IF POSSIBLE.

UNIT PARTS LIST

UNIT NAME	CONTACT DISC	WIPER ASSEMBLY	RATCHET GEAR ASSEMBLY	MOTORS
REPLAY	-----	-----	A-6400	
BALL COUNT	C-6414	B-7456-3	A-6402-10	
NO. MATCH	C-6414	B-7456-2	A-6401	
ADVANCE	C-6417	B-7456-36	A-6402-8	SCORE MOTOR
10 POINT	B-7253	A-6294	3C-7272	14A-7883 (60 CYCLE)
100 POINT	-----	-----	3C-7272	14A-7884 (50 CYCLE)
1000 POINT	B-7253	A-6294	3C-7272	
10000 POINT	B-7253	A-6294	3C-7272	
ALTERNATOR	-----	-----	3C-7272	

IMPORTANT NOTICE

KINDLY INFORM LOCATIONS THAT THEY CAN TURN DISPLAY LIGHTS ON BY PRESSING LEFT FLIPPER BUTTON. MACHINE CAN STILL BE SHUT OFF BY TAPPING BOTTOM OF CABINET.

MASTER SWITCH (ON-OFF) IS LOCATED UNDERNEATH FRONT PART OF CABINET.

CAUTION!

The playboard on this machine has an improved finish with excellent wearing properties. Do not under any circumstances clean the board with water, water soap solutions or harsh abrasives. Avoid such things as steel wool, kitchen cleansers or abrasive hand soap. Water will weaken the adhering of the paint to the board and abrasives shorten the board life by many thousand plays. A wax base cleaner with negligible abrasive qualities used lightly, but frequently, will extend the board life to its full capabilities.

SERVICEMAN TO REMOVE BACKGLASS:

- **WITH BACK DOOR REMOVED, PULL BACK ON BRACKETS AT INSIDE TOP OF LITE BOX.**
- **FROM THE FRONT OF GAME, LIFT GLASS UP AND OUT.**

"SKYLAB" COIL CHART

NOTICE:

THIS GAME OPERATES ON 24 VOLTS. WHEN ORDERING REPLACEMENT TRANSFORMERS, MOTORS, COILS OR METERS ... MAKE SURE TO SPECIFY CORRECT PART NUMBER.

NUMBER	DESCRIPTION	LOCATION
<u>MOTORS & TRANSFORMERS</u>		
14 A-7883	CONTROL MOTOR - 60 CYCLE	MECH. PANEL
14 A-7884	CONTROL MOTOR - 50 CYCLE	MECH. PANEL
15 A-6771	TRANSFORMER - 60 CYCLE	MECH. PANEL
15 A-6782-1	TRANSFORMER - 50 CYCLE	MECH. PANEL
B 6396	24 VOLT METER	MECH. PANEL
<u>SOLENOID COILS</u>		
A 22-550	ADVANCE UNIT STEP UP BALL RELEASE COIL BALL COUNT UNIT STEP UP	PLAYFIELD PLAYFIELD INSERT
A 23-600	MATCH UNIT STEP UP CREDIT UNIT STEP UP	INSERT INSERT
A2-23-750	KNOCKER	CABINET
A2-26-1300	TRIPLE CHIME COILS ... (3 req'd.)	CABINET
B1-26-800	ALTERNATOR UNIT STEP UP SCORE DRUM UNITS ... (4 req'd.) BALL COUNT UNIT RESET CREDIT UNIT RESET ADVANCE UNIT RESET	MECH. PANEL INSERT INSERT INSERT PLAYFIELD
D1-24-1600	RELAY BANK RESET COIL	PLAYFIELD
FL 20-300/ 28-400	FLIPPERS ... (2 req'd.)	PLAYFIELD
G 23-750 D.C.	D.C. JET BUMPER COILS ... (2 req'd.) D.C. KICKER COILS ... (2 req'd.)	PLAYFIELD PLAYFIELD
M 29-1000	GAME OVER RELAY TRIP GAME RELAY TRIP CAPTIVE BALL RELAY TRIP	MECH. PANEL MECH. PANEL PLAYFIELD
M 29-1100	5¢ RELAY 10¢ RELAY 25¢ RELAY 10 PT. RELAY 100 PT. RELAY 1000 PT. RELAY SCORE RESET RELAY SKYLAB RELAY 50 PT. RELAY	MECH. PANEL MECH. PANEL MECH. PANEL INSERT INSERT INSERT INSERT PLAYFIELD PLAYFIELD
M 30-1300	100,000 RELAY	INSERT
M1-31-1500	COIN LOCKOUT COIL	FRONT DOOR
S 27-500	RELAY BANK COILS ... (6 req'd.)	PLAYFIELD
XM 27-675	TOTAL PLAY METER COIL	MECH. PANEL
Z 27-1000	OUT HOLE RELAY RESET RELAY COIN RELAY GAME OVER RELAY LATCH GAME RELAY LATCH SPACELAB SPECIAL RELAY ROCKET SPECIAL RELAY CAPTIVE BALL RELAY LATCH BONUS RELAY	MECH. PANEL MECH. PANEL MECH. PANEL MECH. PANEL MECH. PANEL MECH. PANEL MECH. PANEL PLAYFIELD PLAYFIELD
Z 28-1150	BALL INDEX RELAY 5 BALLS-IN-LINE RELAY CHANGE RELAY SPACELAB RELAY	MECH. PANEL MECH. PANEL PLAYFIELD PLAYFIELD
Z 28-1200	DOUBLE BONUS RELAY	PLAYFIELD
Z 29-1250	LOCK RELAY	MECH. PANEL

JACK LAYOUT

GAME SKYLAB

POSITION PAN.-PLAY F.

FEED	B [ⓐ]
"	R [ⓐ]
MOTOR RUN	%
GAME OVER RE. TRIP	Y/R-1
"	BLU/R-1
BALL RELEASE	BLU/W-4
50 PT. RE.	BR-1
L. FLIPPER	B/W-5 [ⓐ]
R. "	BR/W-5 [ⓐ]
1,000 PT. RE.	GRY/BR
CHANGE RE. W-1	
1,000 PT. LOOPING LITE	BLU/O
ⓐ = PLASTIC	115 V

JACK LAYOUT

GAME SKYLAB

POSITION PAN.-PLAY F.

BLU/BR-1 RESET RE.	SKYLAB BANK RESET O [ⓐ]	SKYLAB BANK RESET
BLU/Y-4 OUTHOLE RE.	"	PURPLE [ⓐ] "
G/W-2 OUTHOLE RE.	10 OPT. RE. G/B	BLU-2 SPACE LAB.
GRY/G-3 BONUS RE.	100 OPT. RE. W/R	BLU/O-5 "
GRY/BLU "	1,000 PT. RE. BR/Y	GRY/Y "
R/G-5 DOUBLE BONUS RE.	ROCKET SPECIAL RE. G/R-1	Y/BR-3 "
O/W ADV. U. STEP UP	SKYLAB RE. R/W-1	B/BLU CAP. BALL RE.
GRY/Y-1 "	100 OPT. RE. Y/R-2	BR-3 1,000 PT. RE.
R/BLU-2 " RESET	" "	R/B-3 1,000 PT. LITE
G/Y-4 " "	NO. MATCH U. BLU/W-2	BLU [ⓐ] LITE FEED
G-1 SPECIAL RE. ^{SPACE LAB}	FEED Y [ⓐ]	GRY/G-4 BALL IND.
R/B-1 CREDIT LITE		
ⓐ = #16 GAUGE	PAN = PANEL	PLAY F. PLAYFIELD

JACK LAYOUT

GAME SKYLAB

POSITION PAN - INSERT

FEED	B [Ⓐ]	1
"	R [Ⓐ]	2
REPLAY UNIT STEP UP	R/ B-5	3
COIN RE	R/O-1	4
"	W/B-1	5
"	W/O	6
COIN LOCKOUT	B/R-2	7
"	W/GRY	8
RESET RE.	BLU/BR-1	9
KNOCKER	B/W	10
NO-MATCH U.	BLU/W-2	11
FEED	Y [Ⓐ]	12
P = PLASTIC 115 V.		

JACK LAYOUT

GAME SKYLAB

POSITION PAN-INSERT

M. CHIME	O-3	1
COIN RE.	R/W	2
REPLAY UNIT STEP UP	R/ BR-4	3
SPACE LAB RE.	BLU/ O-5	4
OUTHOLE RE.	G/W-2	5
"	W/BLU-1	6
BALL INDEX RE.	GRY/ G-4	7
L. CHIME	B/ G-2	8
REPLAY UNIT RESET	B/y	9
COIN RE.	BLU/ W	10
CHANGERE.	W-1	11
PAN = PANEL		
A = # 16 GAUGE		
PLAY F = PLAYFIELD		

O/R-2 S. CHIME
GRY/O-1 BALL COUNT STEP UP
BR/y 1.00OPT.RE.
W/R 100PT. RE.
G/B 10PT. RE.
BLU-2 SPACE LAB RE.
GRY/y " " "
BR/G-2 SCORE ADJ. JAG.
R/B-1 CREDIT LITE.
W/O-3 NO-MATCH FEED LITE
BR[Ⓐ] LITE FEED

INSTRUCTIONS FOR COIN TRIP SWITCH ADJUSTMENT

WIRE SHOULD BE IN CONTACT WITH END OF CRESCENT OPENING WHEN BLADE ADJUSTMENT IS MADE.

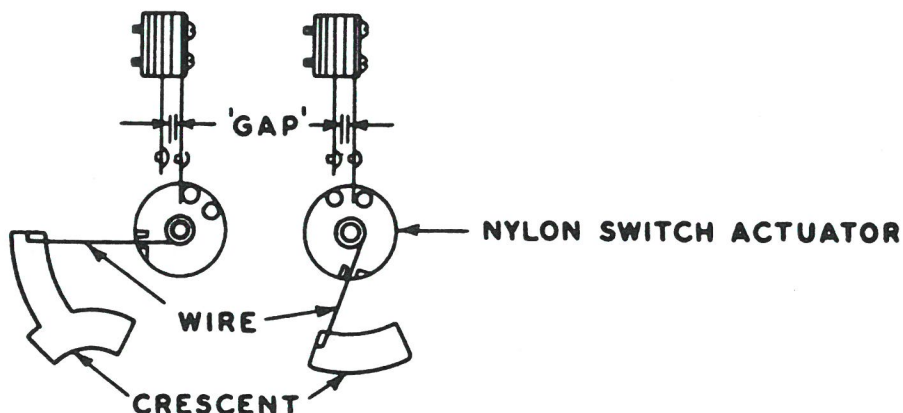

Long blade should be in contact with nylon switch actuator and have a maximum overtravel of 1/32.

or

Using a gram gauge, tension of long blade should not exceed 10 grams.

SWITCH ADJUSTMENT

1. For small coins, such as dimes, adjust short blade so that the 'gap' between the silver contacts is .045 to .055.
2. For larger & heavier coins the 'gap' should be .045 to .060.
3. Do not adjust 'gap' closer than .040.

POWER TRANSFORMER:

LOCATED ON MECHANISM PANEL, IT IS EQUIPPED WITH A SECONDARY TAP. IF YOUR GAME IS ON LOCATION WITH EXTREMELY LOW LINE VOLTAGE, REMOVE LEAD FROM LUG MARKED 24 VOLTS AND SOLDER TO ALTERNATE LUG MARKED "HIGH". THIS WILL BOOST SECONDARY VOLTAGE APPROXIMATELY 2-3 VOLTS.

LEG LEVELERS:

ARE PROVIDED FOR TWO PURPOSES - 1ST TO LEVEL GAME ON LOCATION, 2ND TO INCREASE PITCH FOR GAME PERCENTAGING. IF IT IS DESIRED TO SPEED UP PLAY AND DECREASE SCORES, RAISE REAR LEG LEVELERS TO INCREASE PITCH.

ALTERNATOR UNIT

LOCATED ON MECHANISM PANEL.

USED IN CONJUNCTION WITH 5¢ RELAY FOR "2 COINS-1 PLAY" FEATURE.

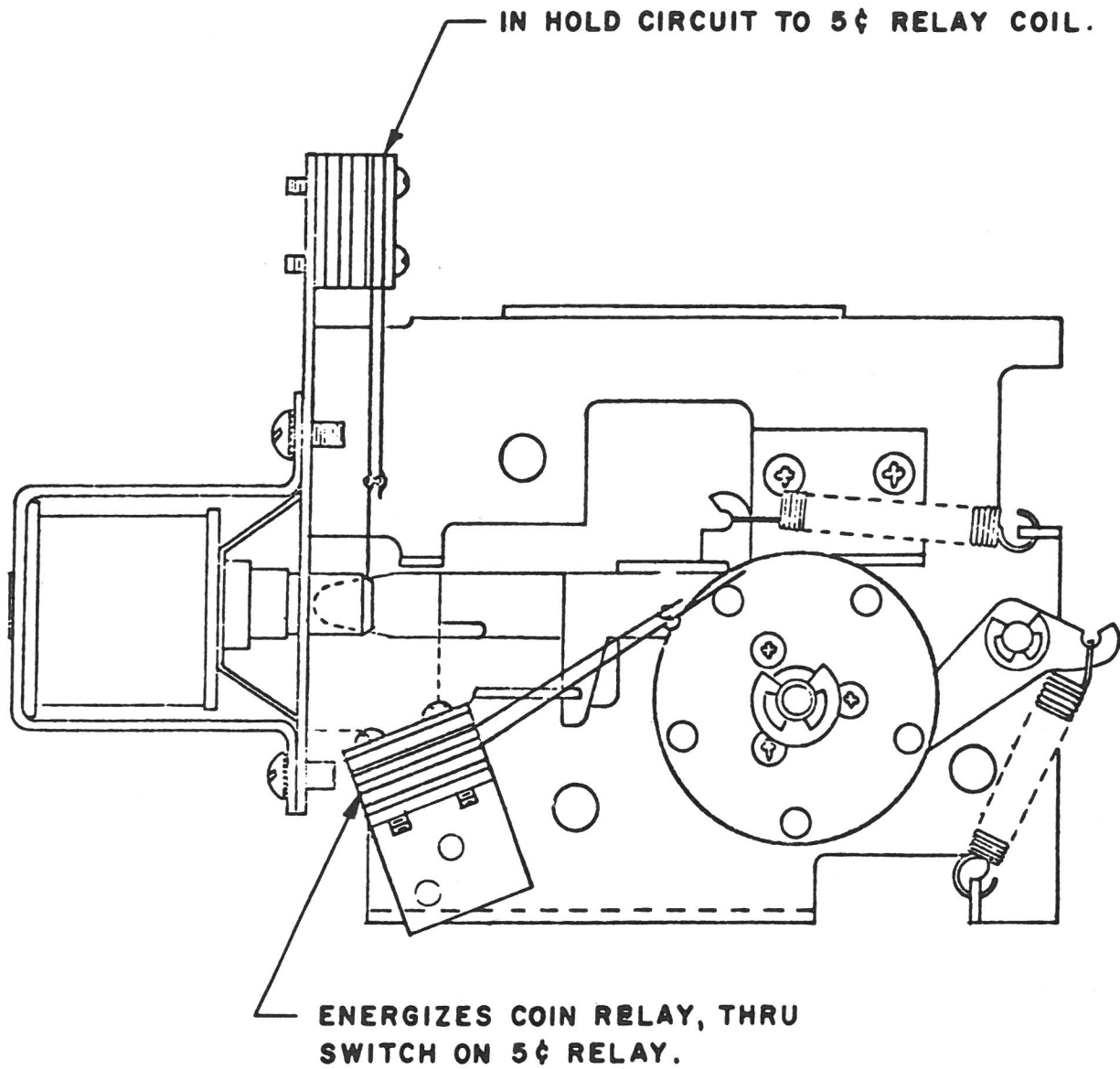

LOCK

IS ENERGIZED BY 5¢ RELAY, LEFT FLIPPER SWITCH OR SCORE MOTOR CAM SWITCH 1B.

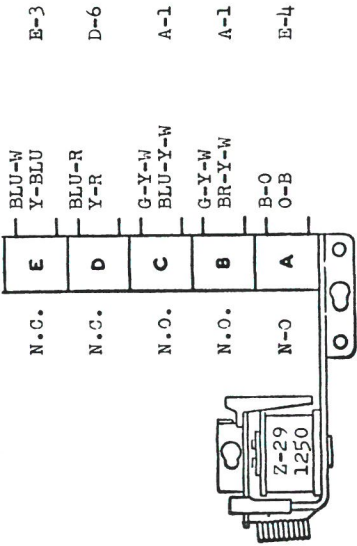

E-3 IN CIRCUIT TO RESET RELAY.
 D-6 IN SERIES WITH SWITCH C ON GAME-OVER RELAY.
 A-1 6 VOLTS FROM TRANSFORMER TO LITES.
 A-1 6 VOLTS FROM TRANSFORMER TO LITES.
 E-4 IN HOLD CIRCUIT TO THIS RELAY, THRU CABINET BOTTOM KICK-OFF SWITCH.

RESET

IS ENERGIZED BY COIN RELAY.

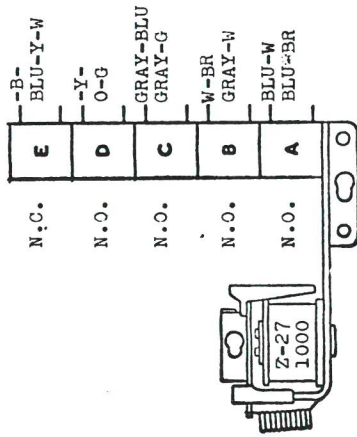

F-9 OPENS CIRCUITS TO MOST PLAYFIELD SWITCHES.
 C-4 RUNS SCORE MOTOR.
 E-9 ENERGIZES BONUS RELAY, THRU ZERO SWITCH ON ADVANCE UNIT.
 D-7 PULSES "SCORE RESET RELAY", THRU IMPULSE CAM SWITCH C.
 D-3 IN HOLD CIRCUIT TO THIS RELAY.

COIN

IS ENERGIZED BY 10¢ COIN SWITCH, IF 10¢ ADJUSTMENT IS IN "1 PLAY" POSITION--- ALSO BY CREDIT BUTTON, THRU ZERO SWITCH ON CREDIT UNIT.

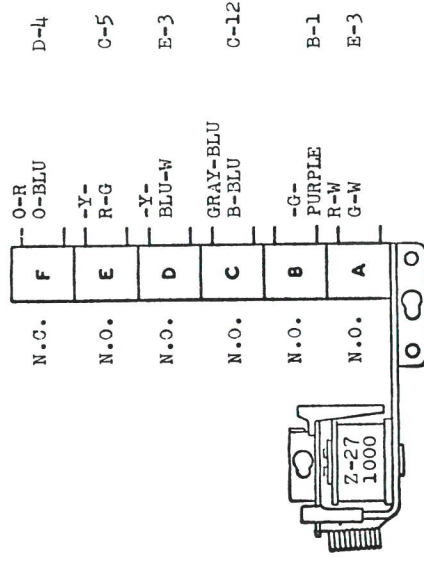

D-4 OPENS CIRCUIT TO KNOCKER COIL.
 C-5 IN CIRCUIT TO LATCH COILS ON GAME RELAY AND GAME-OVER RELAY ---ALSO IN SERIES WITH SWITCH E. ON GAME RELAY.
 E-3 ENERGIZES RESET RELAY.
 C-12 IN CIRCUIT TO CAPTIVE BALL RELAY LATCH OR TRIP COIL.
 B-1 ENERGIZES SKYLAB RELAY BANK RESET COIL, THRU CAM SWITCH 2B.
 E-3 IN HOLD CIRCUIT TO THIS RELAY.

OUTHOLE

IS ENERGIZED BY BONUS RELAY, THRU ADVANCE UNIT ZERO SWITCH AND BALL COUNT UNIT ZERO SWITCH.

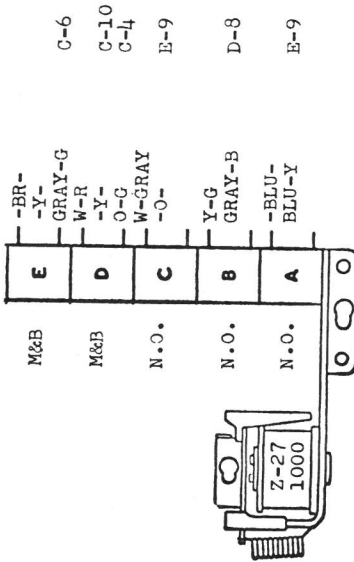

BALL INDEX

IS ENERGIZED BY 10 POINT, 100 POINT OR 1,000 POINT RELAY, THRU WIPER FINGER ON ADVANCE UNIT---ALSO BY OUTHOLE RELAY, THRU GAME-OVER RELAY.

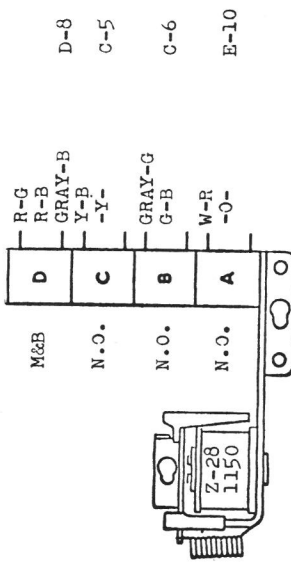

SPACELAB SPECIAL

IS ENERGIZED BY LEFT OR RIGHT BOTTOM OUTSIDE ROLLOVER SWITCH, THRU SWITCH ON CHANGE RELAY AND SPACELAB RELAY.

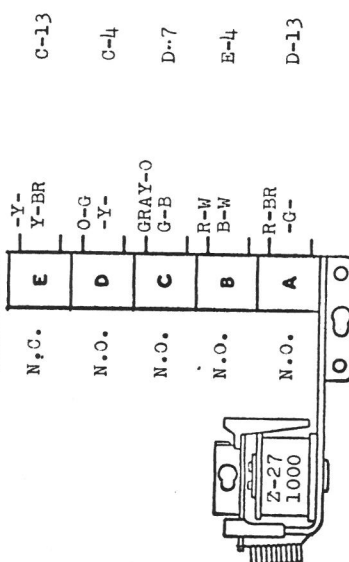

ROCKET SPECIAL

IS ENERGIZED BY LEFT OR RIGHT CAPTIVE BALL SWITCHES (1ST, 3RD & 4TH POSITIONS), THRU SWITCH ON CAPTIVE BALL RELAY AND 5-BALLS-IN-LINE RELAY.

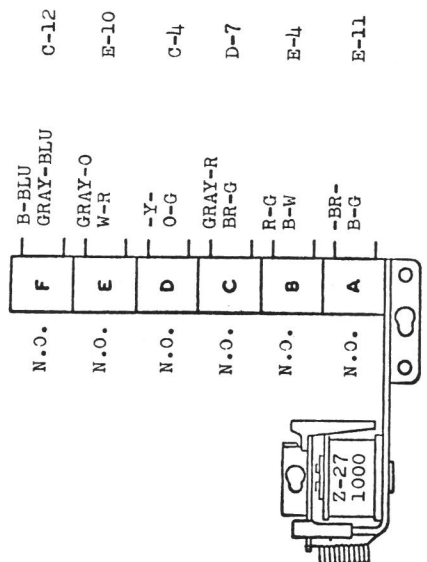

- OPENS IN CIRCUIT TO 1,000 POINT RELAY AND CLOSERS IN SERIES WITH SWITCH B ON BALL INDEX RELAY.
- OPENS IN HOLD CIRCUIT TO BALL INDEX RE. AND 5-BALLS-IN-LINE RE., AND CLOSERS TO RUN SCORE MOTOR.
- ENERGIZES BALL INDEX RELAY, THRU SWITCH ON GAME-OVER RELAY.
- IN NUMBER MATCH CIRCUIT, TO CREDIT S.U. OR BALL COUNT S.U.
- IN HOLD CIRCUIT TO THIS RELAY, THRU CAM SWITCH 5E.
- OPENS IN CIRCUIT TO DOUBLE BONUS RELAY AND CLOSERS IN SERIES WITH SWITCH B ON OUTHOLE RE.
- IN SERIES WITH SWITCH B ON GAME RELAY.
- IN CIRCUIT TO BALL COUNT RESET COIL AND GAME-OVER RELAY TRIP & LATCH COILS.
- IN HOLD CIRCUIT TO THIS RELAY.
- IN HOLD CIRCUIT TO "SPACELAB RELAY".
- RUNS SCORE MOTOR.
- IN CIRCUIT TO CREDIT S.U., BALL COUNT S.U. OR 10,000 POINT DRUM, THRU "PLAY ADJUSTMENT JACK".
- IN CIRCUIT TO KNOCKER COIL.
- HOLD CIRCUIT TO THIS RELAY, THRU CAM SWITCH 6B.
- IN CIRCUIT TO CAPTIVE BALL RELAY LATCH OR TRIP COILS.
- ENERGIZES "5-BALLS-IN-LINE RELAY", THRU SWITCH ON OUTHOLE RELAY.
- RUNS SCORE MOTOR.
- IN CIRCUIT TO BALL COUNT S.U. OR 10,000 POINT DRUM S.U., THRU "PLAY ADJUSTMENT JACK".
- IN CIRCUIT TO KNOCKER COIL.
- HOLD CIRCUIT TO THIS RELAY, THRU CAM SWITCH 5C.

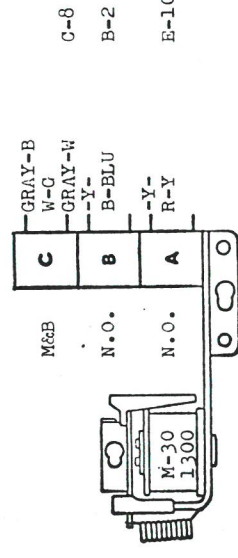
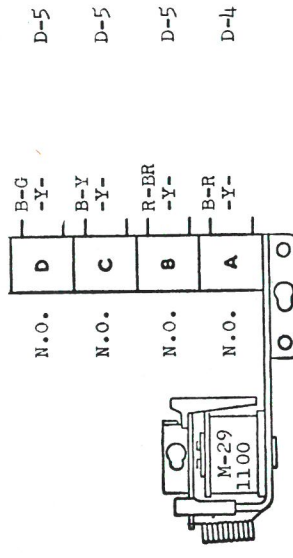
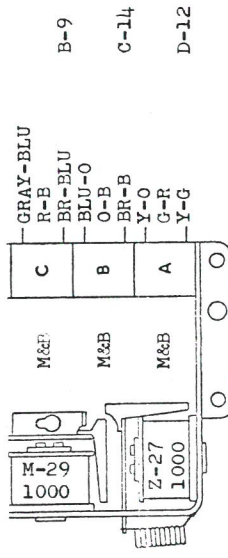
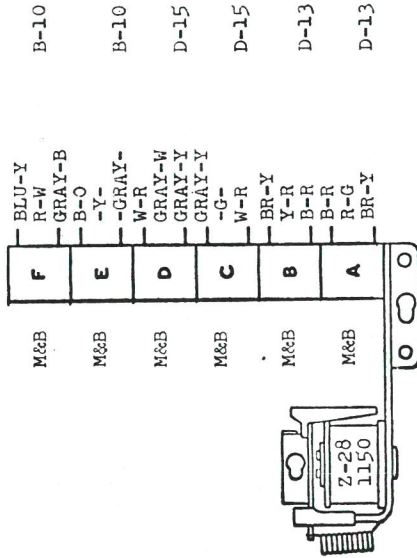

CHANGE

IS ENERGIZED BY WIPER FINGER ON NUMBER MATCH UNIT DISC.

CAPTIVE BALL

LATCH AND TRIP COILS ARE ENERGIZED BY COIN RELAY OR GAME-OVER RELAY OR ROCKET SPECIAL RELAY, THRU LEFT OR RIGHT CAPTIVE BALL SWITCH (2ND POSITION).

SCORE RESET

IS PULSED BY IMPULSE CAM SWITCH C, THRU SWITCH ON RESET RELAY.

100,000

IS ENERGIZED BY END-OF-STROKE SWITCH ON 10,000 POINT DRUM UNIT, THRU 9TH POSITION SWITCH ON 10,000 POINT DRUM UNIT.

B-10 OPENS TO LEFT BOTTOM "SPECIAL" LITE AND CLOSSES TO RIGHT BOTTOM "SPECIAL" LITE.

B-10 OPENS TO LEFT TOP & RIGHT BOTTOM ROLLOVER LITES, & CLOSSES TO R. TOP & L. BOTTOM ROLLOVER LITES.

D-15 OPENS IN CIRCUIT TO 100 POINT RELAY AND CLOSSES TO ADVANCE UNIT S.U. COIL.

D-15 OPENS IN CIRCUIT TO ADVANCE UNIT S.U. COIL, AND CLOSSES TO 100 POINT RELAY.

D-13 OPENS IN CIRCUIT TO 1,000 POINT RELAY AND CLOSSES IN CIRCUIT TO SPACELAB SPECIAL RELAY.

D-13 OPENS IN CIRCUIT TO SPACELAB SPECIAL RELAY AND CLOSSES TO 1,000 POINT RELAY.

B-9 CIRCUIT TO LEFT OR RIGHT CAPTIVE BALL LANE LITE.

C-14 IN SERIES WITH SWITCH C ON 5-BALLS-IN-LINE RELAY.

D-12 IN SERIES WITH SWITCH B ON 5-BALLS-IN-LINE RELAY.

D-5 PULSES 10,000 POINT DRUM UNIT, THRU ZERO SWITCH ON THAT UNIT.

D-5 PULSES 1,000 POINT DRUM UNIT, THRU ZERO SWITCH ON THAT UNIT.

D-5 PULSES 100 POINT DRUM UNIT, THRU ZERO SWITCH ON THAT UNIT.

D-4 PULSES 10 POINT DRUM UNIT, THRU ZERO SWITCH ON THAT UNIT.

C-8 IN HI-SCORE CIRCUIT-OPENS IN 3 BALL PLAY AND CLOSSES IN 5 BALL PLAY FOR SCORES OVER 100,000.

B-2 TO 100,000 POINT LITE.

E-10 HOLD CIRCUIT TO THIS RELAY.

1,000 POINT

IS PULSED BY:

1. LEFT BOTTOM OUTSIDE ROLLOVER SWITCH, THRU SWITCH ON CHANGE RELAY.
2. RIGHT BOTTOM OUTSIDE ROLLOVER SWITCH, THRU SWITCH ON CHANGE RELAY.
3. BONUS RELAY, THRU SWITCHES ON SCORE MOTOR.
4. ADVANCE UNIT END-OF-STROKE SWITCH.
5. RIGHT OR LEFT CAPTIVE BALL SWITCH (4TH POSITION), THRU SWITCH ON CAPTIVE BALL RELAY AND 5-BALLS-IN-LINE RELAY.

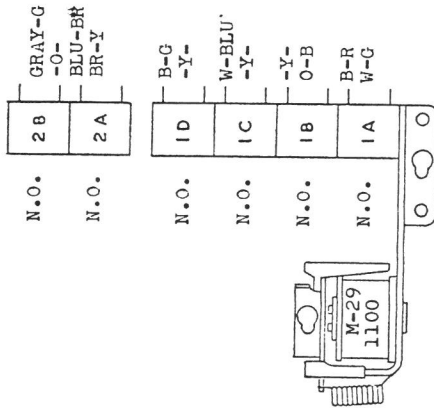

E-10 ENERGIZES BALL INDEX RELAY, THRU WIPER ON ADVANCE UNIT DISC.
E-14 IN HOLD CIRCUIT TO THIS RELAY.

C-15 ENERGIZES LARGE CHIME COIL.

D-5 ENERGIZES 10,000 POINT DRUM UNIT, THRU 9TH POSITION SWITCH ON 1,000 POINT DRUM UNIT.

D-5 PULSES 1,000 POINT DRUM UNIT.

C-8 IN SERIES WITH SWITCH C ON 100,000 RELAY.

100 POINT

IS PULSED BY:

1. LEFT & RIGHT JET BUMPER SWITCHES.
2. NUMBER MATCH UNIT END-OF-STROKE SWITCH.
3. LEFT & RIGHT (TOP & BOTTOM) ROLL-OVER SWITCHES, THRU SWITCHES ON CHANGE RELAY.
4. RIGHT OR LEFT CAPTIVE BALL SWITCH (4TH POSITION), THRU SWITCH ON CAPTIVE BALL RELAY, 5-BALLS-IN-LINE RELAY AND SPACELAB RELAY.

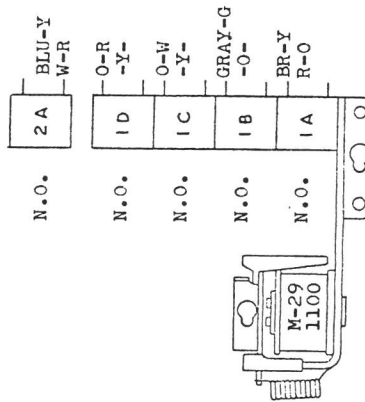

D-14 IN HOLD CIRCUIT TO THIS RELAY.

C-16 ENERGIZES SMALL CHIME COIL.

D-5 PULSES 100 POINT DRUM UNIT.

E-10 ENERGIZES BALL INDEX RELAY, THRU WIPER ON ADVANCE UNIT DISC.

E-14 PULSES 1,000 POINT RELAY, THRU 9TH POSITION SWITCH ON 100 POINT DRUM UNIT.

D-13 IN HOLD CIRCUIT TO THIS RELAY.

C-15 PULSES MEDIUM CHIME COIL.

C-4 PULSES 10 POINT DRUM UNIT.

E-9 ENERGIZES BALL INDEX RELAY, THRU WIPER ON ADVANCE UNIT DISC.

D-14 PULSES 100 POINT RELAY, THRU 9TH POSITION SWITCH ON 10 POINT DRUM UNIT.

10 POINT

IS PULSED BY:

1. LEFT OR RIGHT KICKER SWITCH.
2. 50 POINT RELAY.
3. 'S' OR 'L' STAND-UP SWITCHES.

