

Bally®

BARREL O' FUN '62

(FUN-SPOT '62)

OPERATING INSTRUCTIONS AND PARTS CATALOG

Part Numbers are marked on illustrations
and a list of miscellaneous parts appears
on back cover.

**FOR QUICKEST SERVICE
STATE CORRECT PART NUMBER
WHEN ORDERING PARTS**

Code	
N.C. ---	Normally closed
N.O. ---	Normally open
M.B.B.---	Make before break
S.P.D.T.---	Single pole double throw

Home of Ballygames and Ballyrides

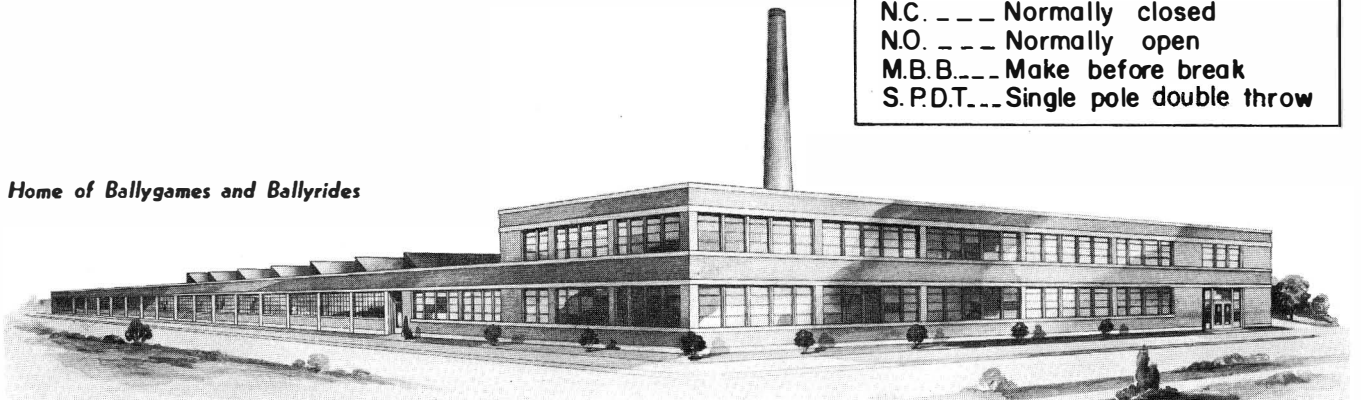

SELECTION UNIT DISC viewed from BUTTON or WIPER side

6 step unit. Wipers shown in zero or reset position

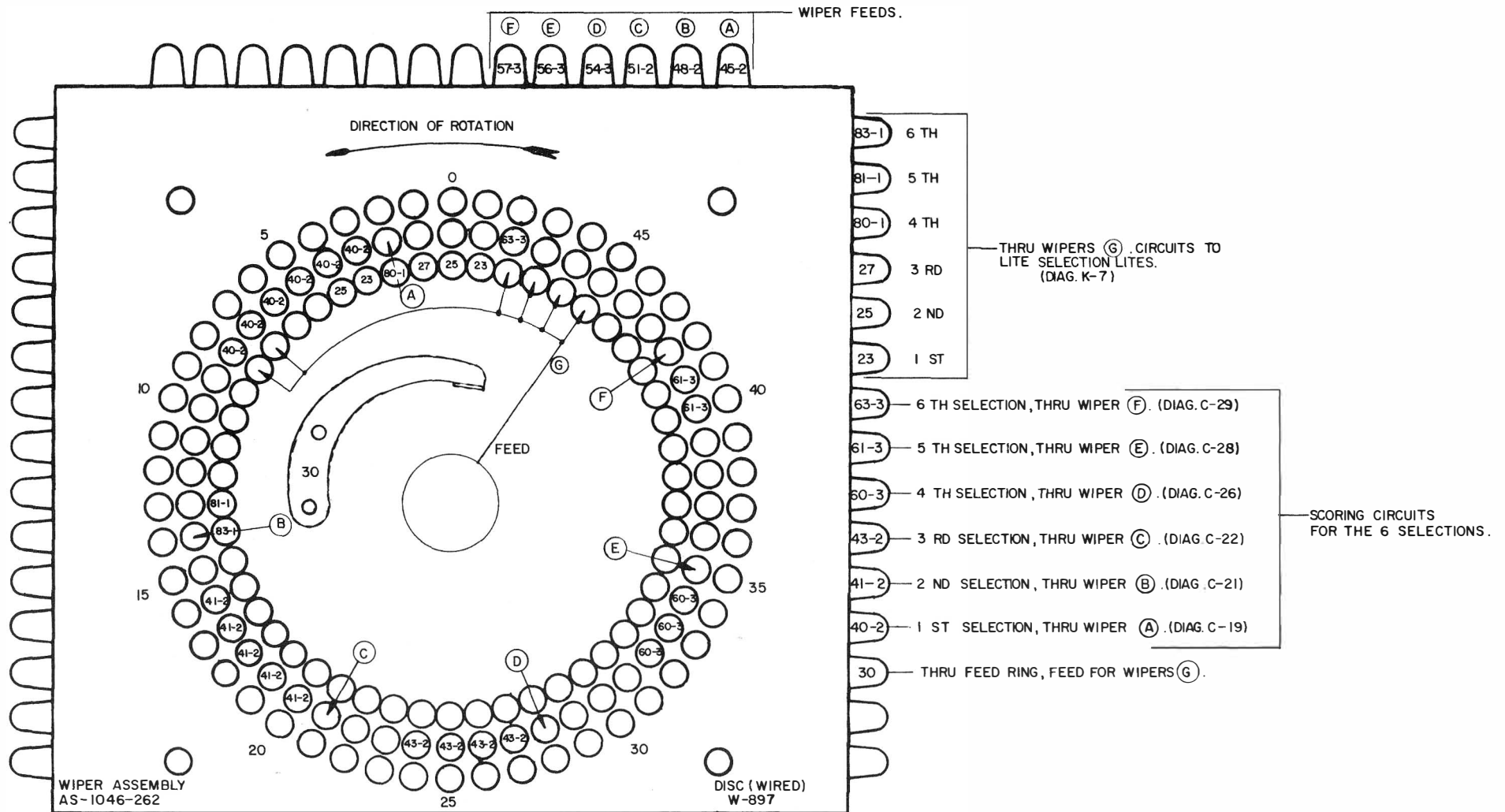

- COMPLETE UNIT.....AS-1022-47
- RESET COIL.....28-R-15
- STEP-UP COIL.....25-GG-7
- STEP-UP PLUNGER.....S-496-100
- STEP-UP ARM.....A-1765-4
- RATCHET & SHAFT.....C-1050-6-39

COIN UNIT DISC viewed from **BUTTON** or **WIPER** side

Continuous step unit.

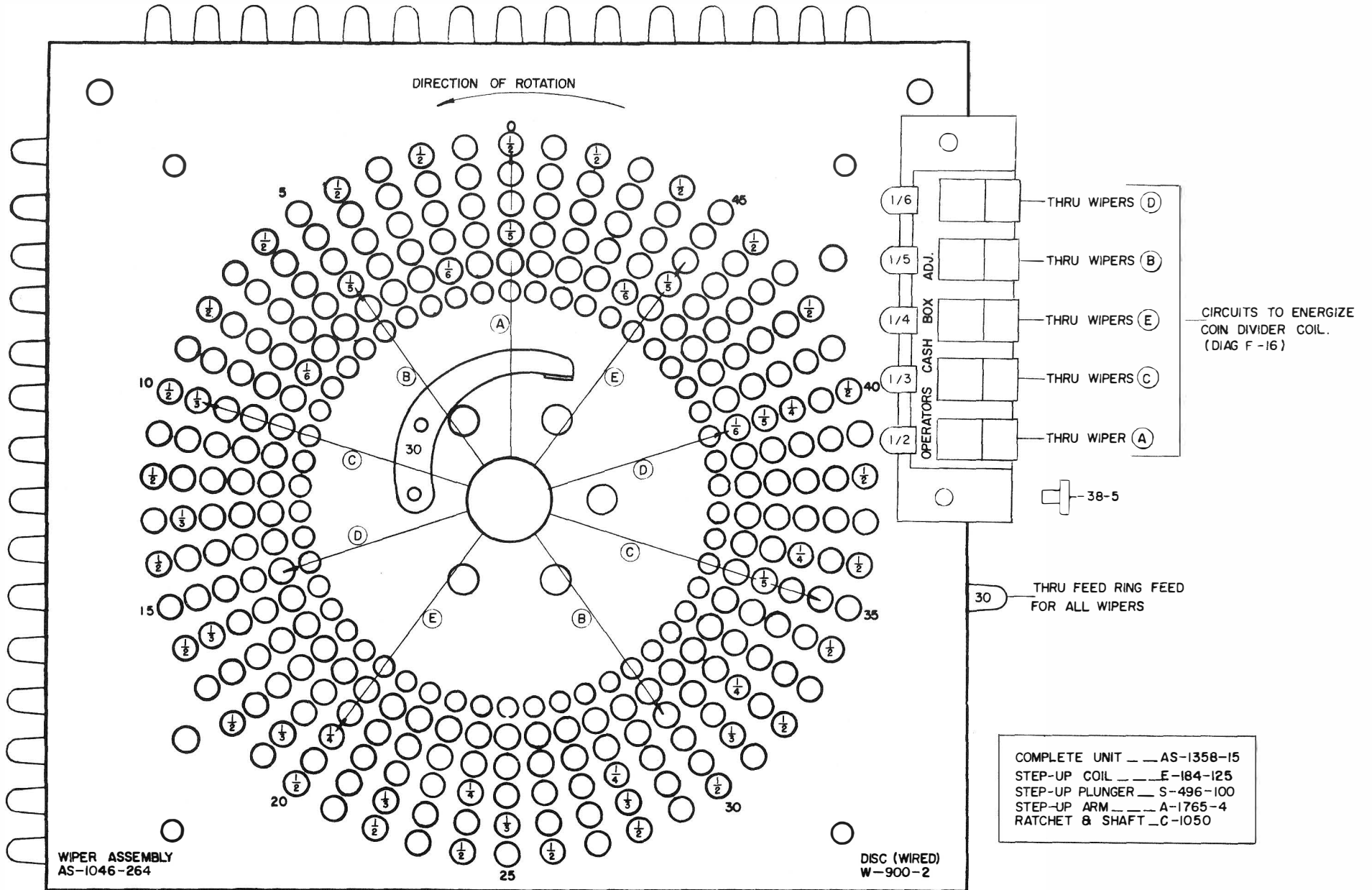

SPOTTING UNIT DISC viewed from BUTTON or WIPER side

Continuous step unit.

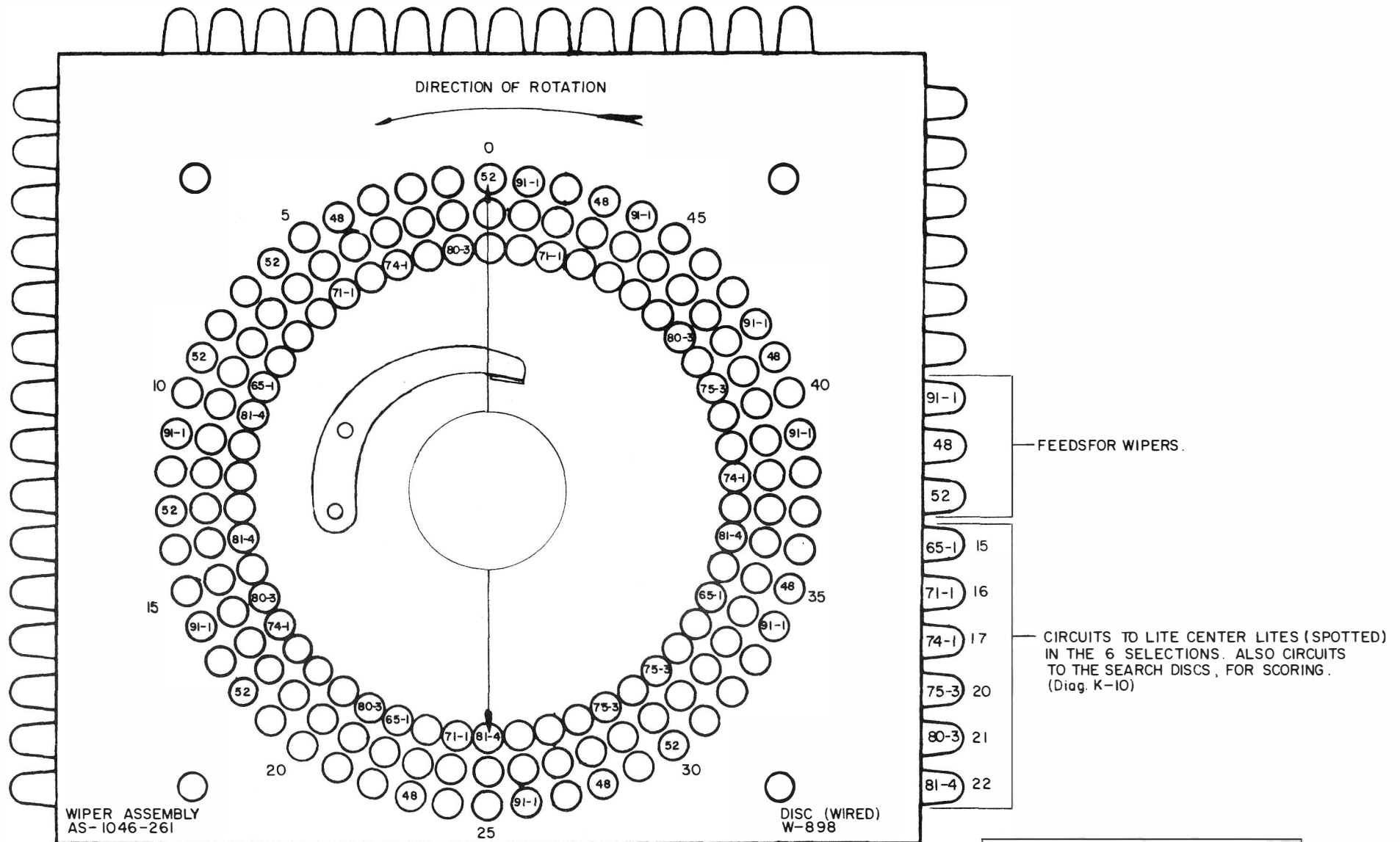

- COMPLETE UNIT.....AS-1358-10
- STEP-UP COIL.....E-184-125
- STEP-UP PLUNGER.....S-496-100
- STEP-UP ARM.....A-1765-4
- RATCHET & SHAFT.....C-1050

9 **SCORE INDICATOR UNIT** viewed from WIPER side

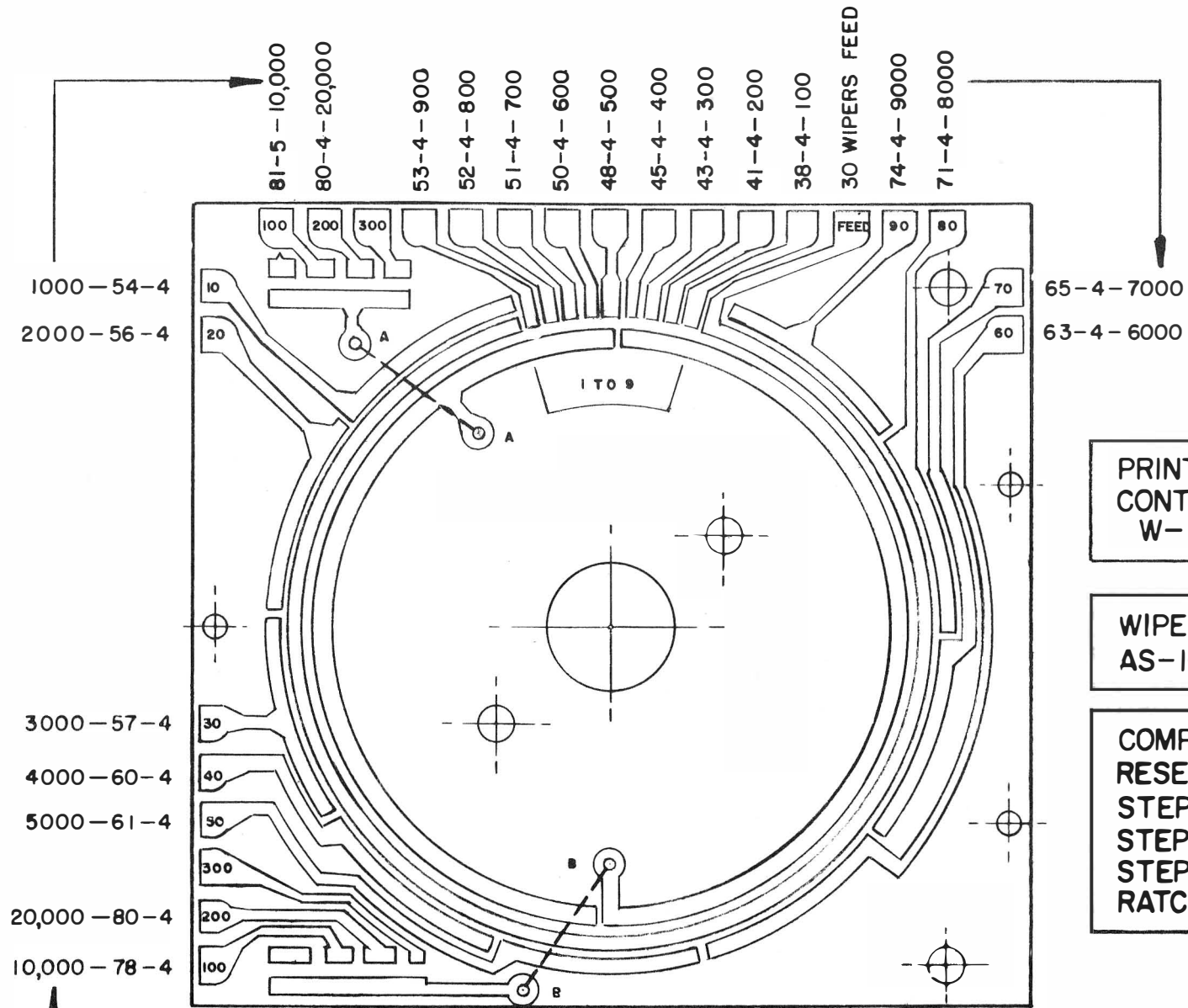

PRINTED CIRCUIT
CONTACT PLATE
W-923-3

WIPER ASSEMBLY
AS-1046-293

COMPLETE UNIT AS-797-50
RESET COIL — 28-R-15
STEP-UP COIL — 25-GG-7
STEP-UP PLUNGER — S-496-116
STEP-UP ARM — A-1765-6
RATCHET & SHAFT — C-100

SCORE INDICATOR LITES
(DIAG. K-1, K-3)

SCORE COUNTER viewed from BUTTON or WIPER side

6 used (see code box at right)

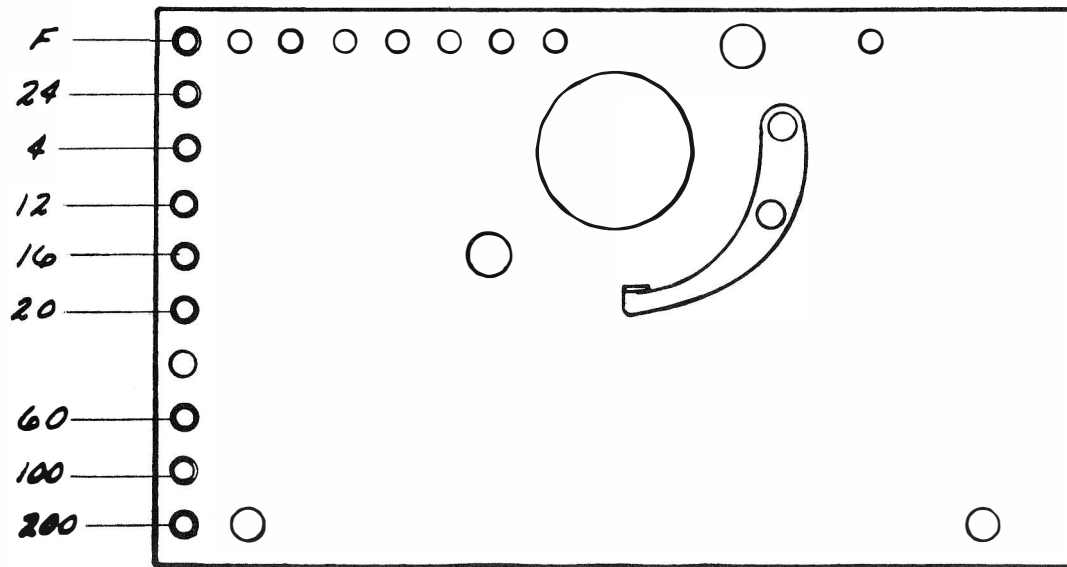

LUG	SCORE COUNTERS					
	#1	#2	#3	#4	#5	#6
F	45-2	48-2	51-2	54-3	56-3	57-3
24	14-4	23-6	36-6	48-6	53-6	61-6
4	52-2	52-2	52-2	52-2	52-2	52-2
12	10-6	18-6	27-6	71-6	51-6	56-6
16	53-2	53-2	53-2	53-2	53-2	53-2
20	13-4	21-6	31-6	43-6	52-6	57-6
60	15-4	25-6	38-6	75-6	50-6	63-6
100	54-2	54-2	54-2	54-2	54-2	54-2
200	60-2	60-2	60-2	48-3	48-3	48-3

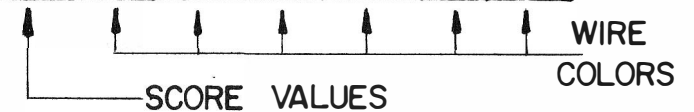

COMPLETE UNIT — AS-797-51
 RESET COIL — 28-R-15
 STEP-UP COIL — 25-GG-7
 STEP-UP PLUNGER — S-496-116
 STEP-UP ARM — A-1765-4
 RATCHET & SHAFT — C-100

PRINTED CIRCUIT
 CONTACT PLATE
 W-945

WIPER ASSEMBLY
 (NOT SHOWN)
 AS-1046-263

SEARCH DISC for Selections 1, 2, 3 viewed from BUTTON or WIPER side

THRU WIPERS [A],[B],[C],[D],[E],
CIRCUITS FROM PANEL SWITCHES
TO ENERGIZE SEARCH RELAYS FOR
SCORING IN SELECTIONS 1,2,AND3.
(DIAG. K-31)

THRU WIPERS [G], CIRCUIT TO
ENERGIZE SELECTION 4,5,6
SEARCH WIPER LOCK COIL.
(DIAG. D-11)

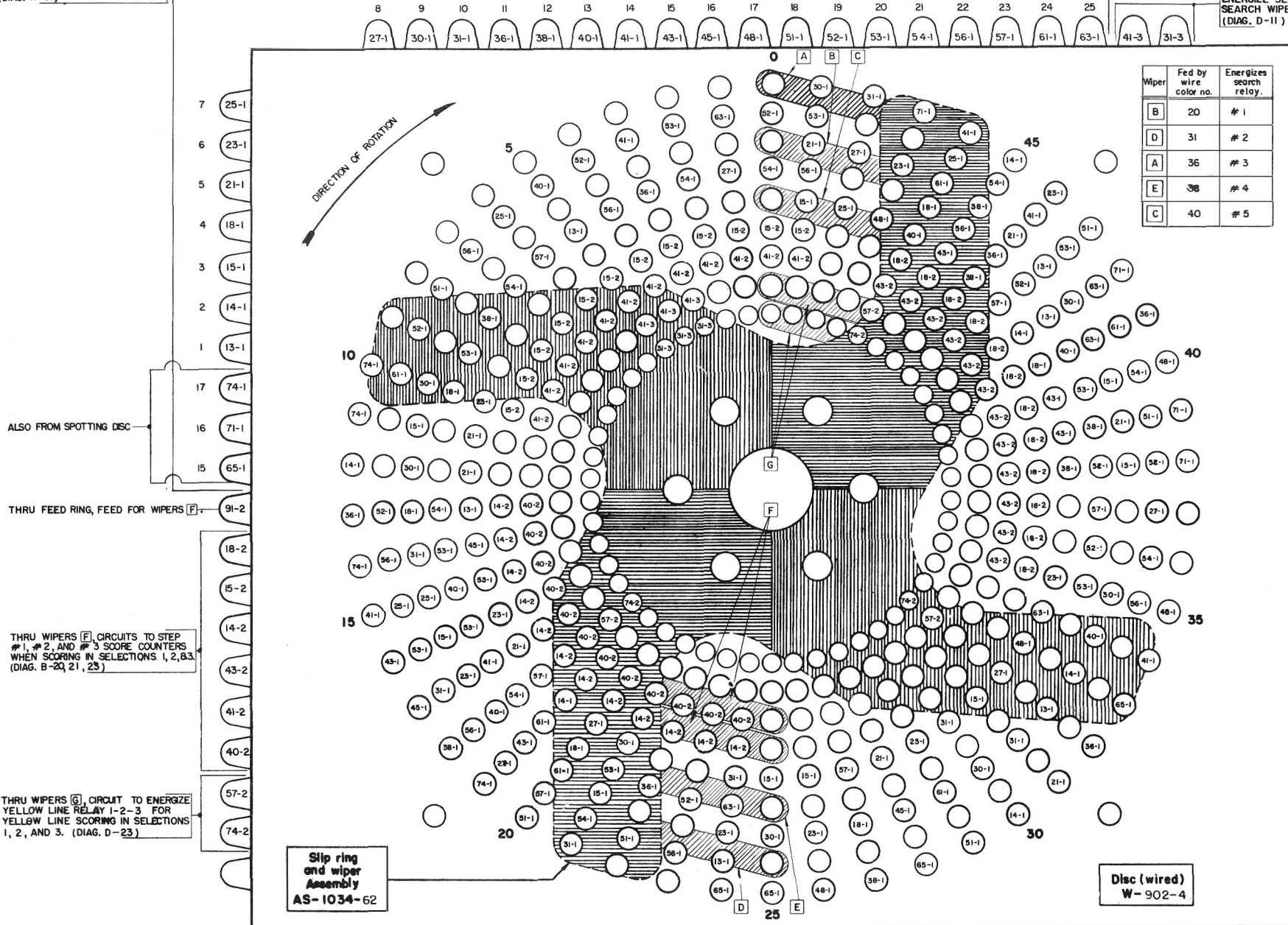

SELECTIONS 1-2-3.

SEARCH POSITIONS CHART

		WIPER [A] AT POSITION	WIPER [B] SEARCH RELAY # 1	WIPER [D] SEARCH RELAY # 2	WIPER [A] SEARCH RELAY # 3	WIPER [E] SEARCH RELAY # 4	WIPER [C] SEARCH RELAY # 5		
		1							
		2							
		3							
		4							
		5							
		6							
		7							
		8							
		9							
DIAGONAL	}	10	9	22	17	20	6	SELECTION-3	}
		11	3	21	17	19	5		
	12	9	8	2	23	5			
	13	4	22	11	19	1			
VERTICAL	}	14	10	18	17	12	16		
		15	7	21	14	20	25		
	16	3	24	15	13	6			
	17	6	25	16	1	5			
YELLOW LINE	}	18	13	20	12	19	23		
HORIZONTAL		19	15	14	17	11	2		
		20	24	21	18	22	8		
		21	3	7	10	4	9		
		22							
		23							
DIAGONAL	}	24	6	20	15	22	10	SELECTION-2	}
		25	9	19	15	21	3		
	26	6	25	17	8	3			
	27	4	20	12	21	23			
VERTICAL	}	28	16	14	15	11	5		
		29	24	19	18	22	7		
	30	9	13	2	1	10			
	31	10	7	5	23	3			
YELLOW LINE	}	32	1	22	11	21	8		
HORIZONTAL		33	2	18	15	12	17		
		34	13	19	14	20	25		
		35	9	24	16	4	6		
		36							
		37							
DIAGONAL	}	38	3	19	16	21	12	SELECTION-1	}
		39	5	22	16	20	15		
	40	3	7	17	13	15			
	41	25	19	11	20	4			
VERTICAL	}	42	9	10	16	14	2		
		43	1	22	18	21	23		
	44	5	8	6	24	12			
	45	12	23	2	4	15			
YELLOW LINE	}	46	24	21	14	20	13		
HORIZONTAL		47	6	18	16	11	17		
		48	8	22	10	19	7		
		49	5	1	9	25	3		
		50							

SEARCH DISC for Selections 4, 5, 6 viewed from BUTTON or WIPER side

THRU WIPERS [A], [B], [C], [D], [E]
CIRCUITS FROM PANEL SWITCHES
TO ENERGIZE SEARCH RELAYS
FOR SCORING IN SECTIONS
4, 5, AND 6. (DIAG. K-31)

THRU WIPERS [G] CIRCUIT TO
ENERGIZE SELECTION 1, 2, 3
SEARCH WIPER LOCK COIL.
(DIAG. B-11)

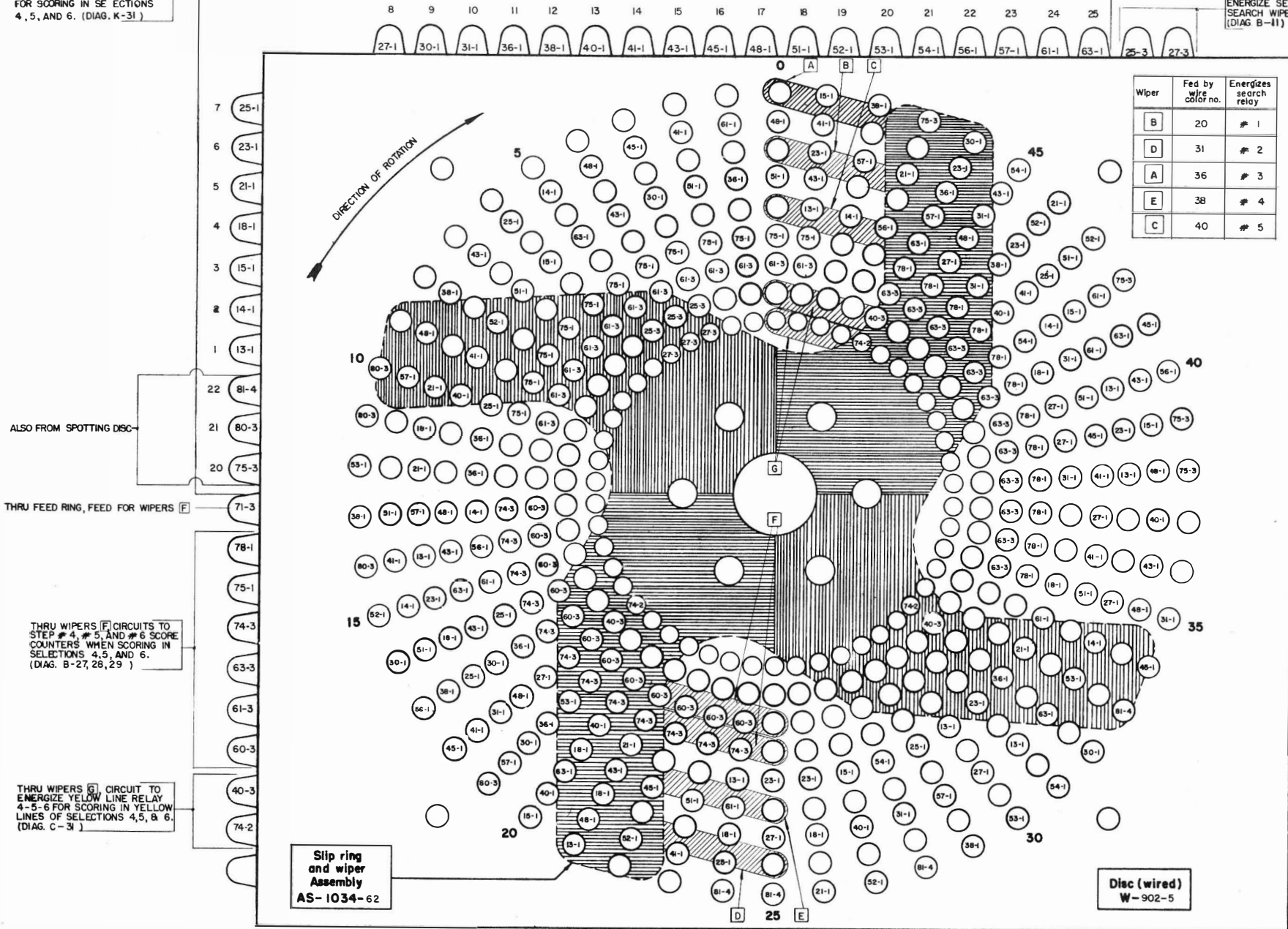

ALSO FROM SPOTTING DISC

THRU FEED RING, FEED FOR WIPERS [F]

THRU WIPERS [F] CIRCUITS TO STEP # 4, # 5, AND # 6 SCORE COUNTERS WHEN SCORING IN SECTIONS 4, 5, AND 6. (DIAG. B-27, 28, 29)

THRU WIPERS [G] CIRCUIT TO ENERGIZE YELLOW LINE RELAY 4-5-6 FOR SCORING IN YELLOW LINES OF SECTIONS 4, 5, & 6. (DIAG. C-3)

SELECTIONS 4-5-6.

SEARCH POSITIONS CHART						
WIPER [A] AT POSITION	WIPER [B] SEARCH RELAY # 1	WIPER [D] SEARCH RELAY # 2	WIPER [A] SEARCH RELAY # 3	WIPER [E] SEARCH RELAY # 4	WIPER [C] SEARCH RELAY # 5	
1						
2						
3						
4						
5						
6						
7						
8						
9						
DIAGONAL	10	5	17	21	18	7
	11	4	15	21	14	11
VERTICAL	12	5	13	20	8	11
	13	23	17	12	14	2
	14	1	3	21	16	22
YELLOW LINE	15	6	15	19	18	24
	16	4	25	9	10	7
	17	7	24	22	2	11
	18	10	18	16	14	8
HORIZONTAL	19	9	19	21	12	20
	20	25	15	3	17	13
	21	4	6	1	23	5
22						
23						
DIAGONAL	24	4	14	22	15	1
	25	8	17	22	18	6
VERTICAL	26	4	24	5	11	6
	27	13	14	19	18	3
	28	10	16	22	9	21
	29	23	17	12	15	7
YELLOW LINE	30	8	2	20	25	1
	31	1	7	21	3	6
	32	25	15	9	18	11
	33	20	12	22	19	5
	34	2	17	16	14	24
HORIZONTAL	35	8	23	10	13	4
	36					
37						
DIAGONAL	38	1	18	20	17	10
	39	6	14	20	15	8
VERTICAL	40	1	2	22	25	8
	41	24	18	16	15	4
	42	3	12	20	9	21
	43	7	14	19	17	13
	44	6	23	5	11	10
YELLOW LINE	45	10	13	21	4	8
	46	11	17	9	15	25
	47	5	19	20	16	22
	48	23	14	12	18	2
HORIZONTAL	49	6	7	3	24	1
	50					

CONTROL UNIT PICTORIAL VIEW NUMBERS CORRESPOND TO SWITCH CHART ON PAGE 13

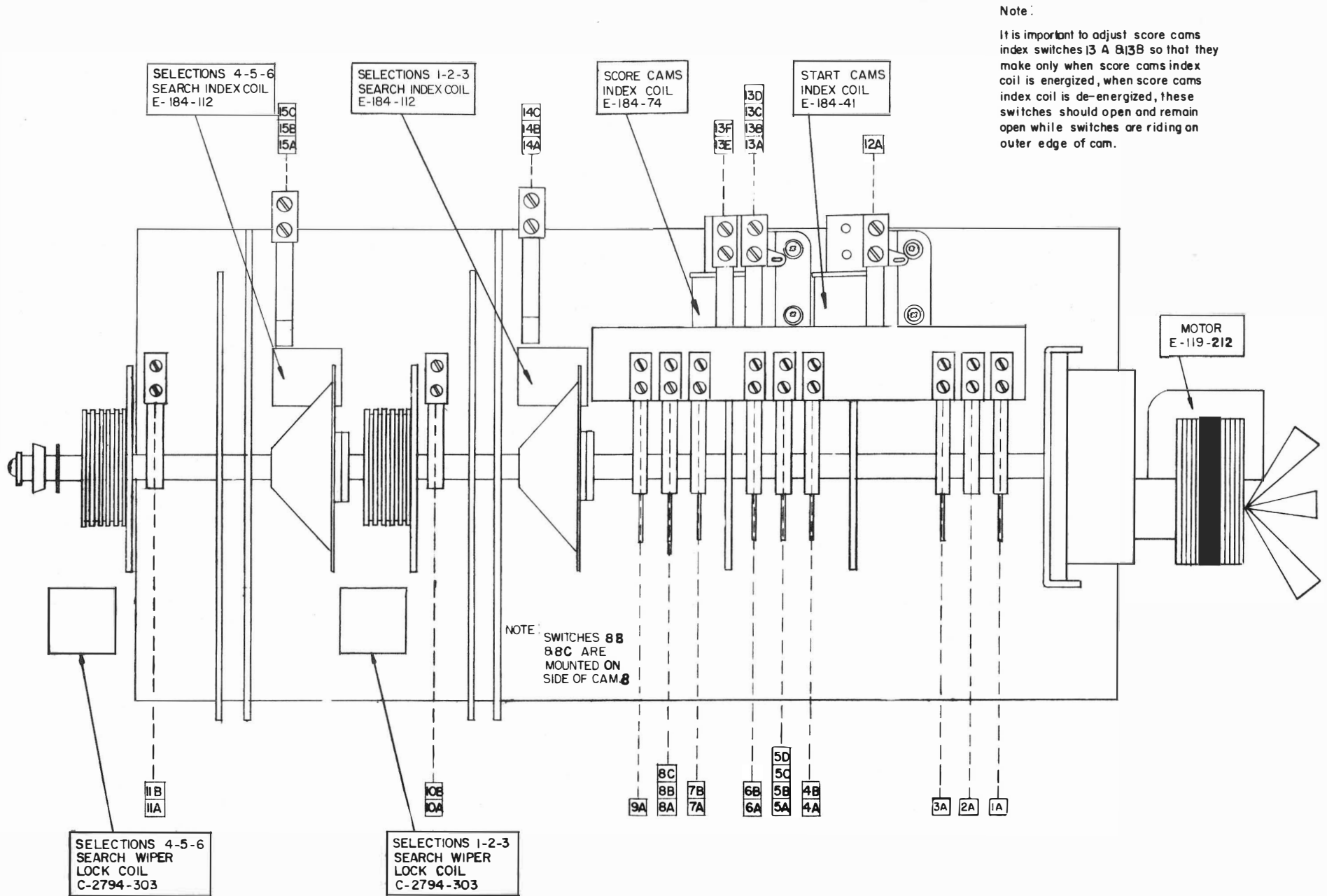

Note:

It is important to adjust score cams index switches 13 A & 13B so that they make only when score cams index coil is energized, when score cams index coil is de-energized, these switches should open and remain open while switches are riding on outer edge of cam.

CONTROL UNIT CAM SWITCH CHART FOR POSITION OF SWITCHES REFER TO PICTORIAL VIEW ON PAGE 12

CAM SWITCH	LOCATION ON DIAGRAM	WIRE No.	WIRE COLORS	FUNCTION OF SWITCHES
1A N.O.	C-14	10-2 13-2	Red Red-Yellow	In series with control unit cam switch #4B, energizes spotting unit step-up coil.
2A N.O. PIN SWITCH	E-8	63-2 40-7	Brown-Yellow Green	Pulses timer unit step-up coil, when circuit complete thru other factors.
3A N.O. 16PULSE	C-7	75 83	Orange-White Black-Yellow	Pulses score indicator escapement coil, when score reset relay is energized.
4A N.C.	I-6	93-1 30	Gray-Yellow Yellow	Opens start circuit.
4B N.O.	D-14	10-2 36-4	Red Yellow-Brown	In series with control unit cam switch #1A, energizes spotting unit step-up coil.
5A N.O.	C-4	51 30	White-Red Yellow	Energizes anti-cheat relay.
5B N.O.	F-8	45 63	Green-White Brown-Yellow	Pulses coin unit step-up coil on each coin played, when score indicator unit is at zero.
5C N.O.	F-8	50-1 63	White Brown-Yellow	Pulses coin unit step-up coil on 1st coin played, when score indicator unit is not at zero. (Fun-spot operation)
5D S.P.D.T.	D-6	81 14-5 13-5	Black-Red Red-Green Red-Yellow	Opens start circuit, and completes a circuit to energize tilt relay if coin switch is closed too long. (Anti-cheat coin switch circuit)
6A N.O.	F-14	36-4 53-3	Yellow-Brown White-Yellow	Pulses selection unit step-up coil.
6B N.O.	G-5	43 30	Green-Yellow Yellow	Pulses score indicator unit escapement coil, when score reset relay is not energized.
7A N.O.	A-19	75-4 90	Orange-White Gray	Pulses score counter unit #1, #2 or #3 step-up coil, when a scoring circuit is completed in selections 1-2 or 3.
7B N.O.	A-25	78-2 80	Orange-Black Black	Pulses score counter unit #4, #5 or #6 step-up coil, when a scoring circuit is completed in selection 1, 2 or 3.
8A N.O.	D-15	21-2 23-2	Blue-Red Blue-Yellow	Pulses score indicator unit step-up coil when a scoring circuit is completed.
8B N.O. VERTICAL SWITCH	E-17	27-2 91-2	Blue-Orange Gray-Red	In series with scoring lock-in circuit when scoring in selections 1, 2 or 3.
8C N.O. VERTICAL SWITCH	E-25	27-2 71-3	Blue-Orange Orange-Red	In series with scoring lock-in circuit when scoring in selections 4, 5 or 6.
9A N.C.	H-17	50 90-1	White Gray	In series with scoring circuits when scoring in any selections.
SELECTIONS 1-2-3SEARCH WIPER LOCK COIL	A-11	27-3 70	Blue-Orange Orange	Energized when 4th ball is raised to playfield, and releases selections 1-2-3 search wipers to search for scores.
SEARCHCAM 10A N.O.	F-2	10P 20P	Red(Plastic) Blue(Plastic)	Completes a circuit to control unit motor.
SEARCHCAM 10B S.P.D.T.	D-11	23-3 38-7 31-3	Blue-Yellow Yellow-Black Yellow-Red	Directs circuit to energize selection 1-2-3, search wiper lock coil, or selection 4-5-6 search wiper lock coil.

CAM SWITCH	LOCATION ON DIAGRAM	WIRE No.	WIRE COLORS	FUNCTION OF SWITCHES
SELECTIONS 4-5-6SEARCH WIPER LOCK COIL	A-11	41-3 70	Green-Red Orange	Energized when search for scores in selections 1-2-3 is completed, and releases selections 4-5-6 search wipers to search for scores.
SEARCHCAM 11A N.O.	F-2	10P 20P	Red(Plastic) Blue(Plastic)	Completes a circuit to control unit motor.
SEARCHCAM 11B S.P.D.T.	C-11	27-3 23-3 25-3	Blue-Orange Blue-Yellow Blue-White	Directs circuit to energize selections 1-2-3 search wiper lock coil at start of search cycle, or after selection 4-5-6 search cycle is completed.
START CAMS INDEX COIL	A-10	56 70	White-Brown Orange	Energized thru shutter motor cam switch #4C when start relay is energized.
12A N.O.	E-2	10P 20P	Red(Plastic) Blue(Plastic)	Completes a circuit to run control unit motor.
SCORE CAMS INDEX COIL	A-15	21-2 70	Blue-Red Orange	Energized when scoring in any selection, and releases scoring cams.
13A N.O.	H-17	27-2 50	Blue-Orange White	In series with scoring lock-in circuits when scoring in any selection.
13B N.O.	H-16	50 90-1	White Gray	Same as above switch.
13C N.C.	B-17	51-3 91-2	White-Red Gray-Red	Opens direct 50 volt circuit to selection 1-2-3 search index coil, coil then held in thru resistor.
13D N.C.	B-25	52-3 71-3	White-Blue Orange-Red	Opens direct 50 volt circuit to selection 4-5-6 search index coil, coil then held in thru resistor.
13E N.O.	E-2	10P 20P	Red(Plastic) Blue(Plastic)	Completes a circuit to run control unit motor.
13F N.C.	E-8	61-2 63-2	Brown-Red Brown-Yellow	Opens timer unit step-up circuit.
SELECTIONS 1-2-3SEARCH INDEX COIL	B-17	51-3 90	White-Red Gray	Energized when a scoring circuit is completed in selection 1-2 or 3.
14A N.C.	H-6	15-5 93-1	Red-White Gray-Yellow	Opens start circuit.
14B N.C.	A-25	80 70	Black Orange	Opens circuit to selection 4-5-6 search index coil.
14C N.O.	H-15	21-2 91-2	Blue-Red Gray-Red	In series with a circuit to energize score cams index coil, and step score indicator unit.
SELECTIONS 4-5-6SEARCH INDEX COIL	B-25	52-3 80	White-Blue Black	Energized when a scoring circuit is completed in selection 4, 5 or 6.
15A N.C.	G-6	15-5 57	Red-White White-Orange	Opens start circuit.
15B N.C.	A-17	90 70	Gray Orange	Opens circuit to selection 1, 2, 3 search index coil.
15C N.O.	G-15	21-2 71-3	Blue-Red Orange-Red	In series with a circuit to energize score cams index coil, and step score indicator unit.

SHUTTER MOTOR PICTORIAL VIEW

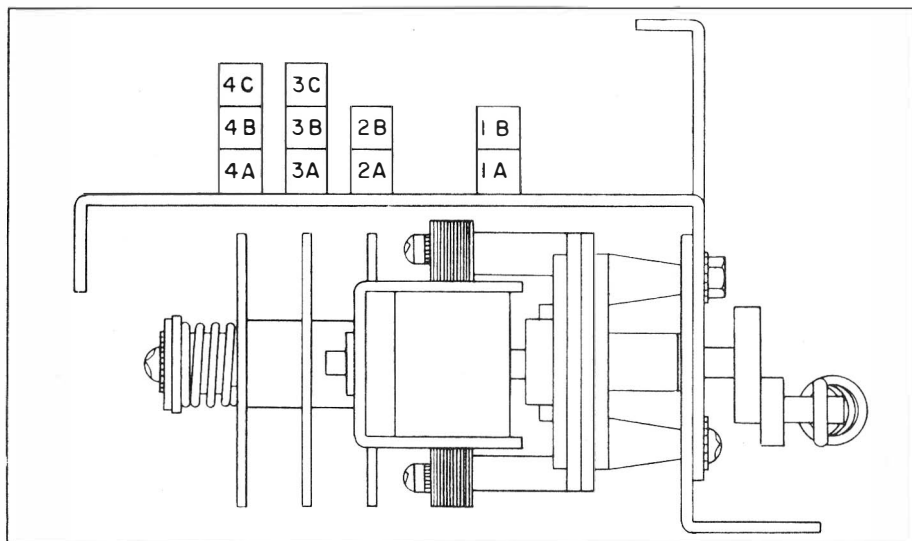

SHUTTER MOTOR CAM SWITCH CHART FOR POSITION OF SWITCHES SEE PICTORIAL VIEW

CAM SWITCH	LOCATION ON DIAGRAM	WIRE No.	WIRE COLORS	FUNCTION OF SWITCHES	
1A	N.C.	1-16	90-1 30	Gray Yellow	(Closed when shutter is closed) in series with scoring circuit.
1B	N.O.	C-9	80-2 30	Black Yellow	Completes shutter motor carry-over circuit.
2A	N.O.	H-10	98 30	Gray-Black Yellow	Energizes ball gate relay when starting new game.
2B	N.O.	H-12	85 30	Black-White Yellow	Resets score counter units, selection unit, timer unit, and energizes tilt reset coil when starting new game.
3A	N.O.	F-9	38-2 61	Yellow-Black Brown-Red	(Closed when shutter is open) in series with circuit to close shutter if game is tilted when shutter is open.
3B	N.C.	J-9	91-1 30	Gray-Red Yellow	(Closed when shutter is closed) in series with circuit to lite spotted number lites.
3C	N.O.	D-9	61 80-2	Brown-Red Black	(Closed when shutter is open) in series with circuit to close shutter when game is tilted when shutter is open. Also in series with circuit to close shutter when 1st ball is shot.
4A	N.O.	C-7	78 81	Orange-Black Black-Red	(Closed when shutter is open) in series with automatic start circuit thru red button adjustment plug.
4B	N.C.	G-8	60-1 93-2	Brown Gray-Yellow	(Closed when shutter is closed) in series with timer unit step-up circuit. Also in series with search circuit.
4C S.P.D.T.	B-9	80-2 54 56	Black White-Green White-Brown		Directs circuit to open shutter, and energize start cams index coil when start relay is energized.

SHUTTER MOTOR

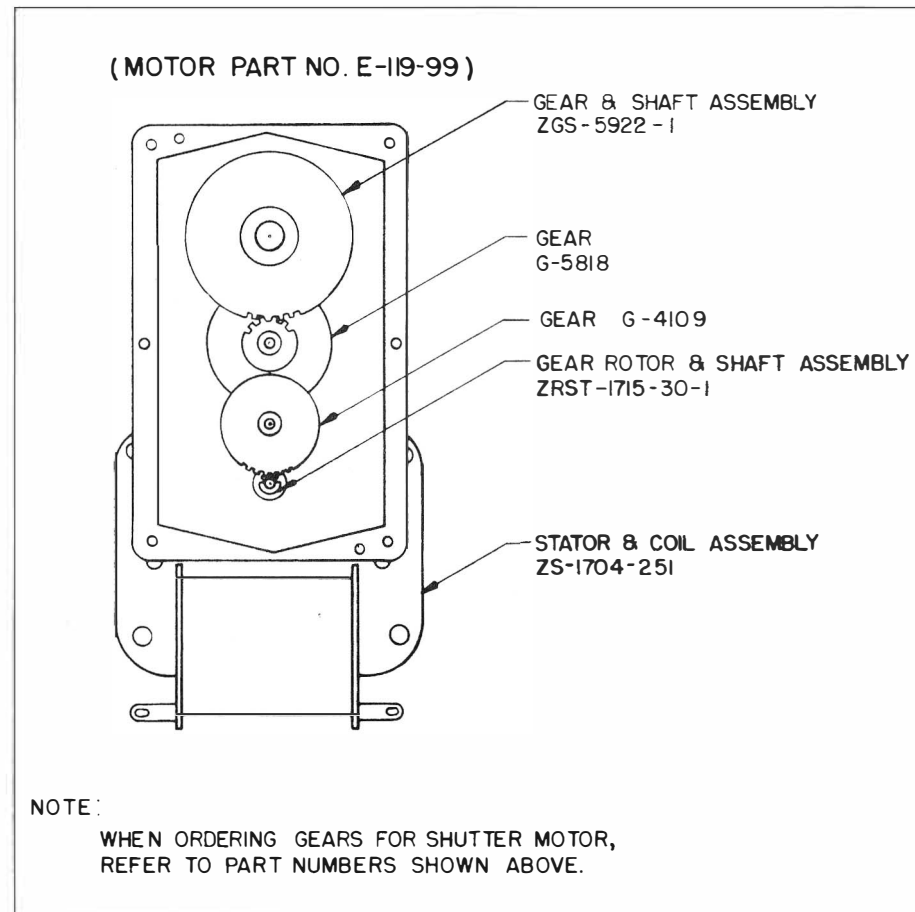

5 RELAYS BANK PICTORIAL VIEW

NUMBERS CORRESPOND TO SWITCH CHART AT RIGHT

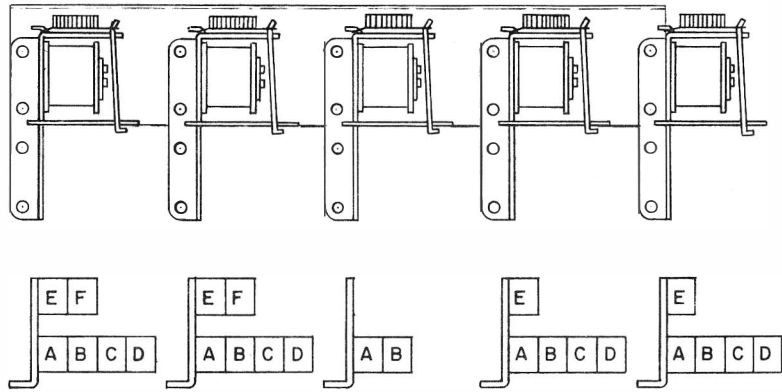

Name	4-5-6 YELLOW LINE RE.	1-2-3 YELLOW LINE RE.	START RE.	ANTI-CHEAT RE.	SCORE RESET RE.
Coil turns & wire gauge	1700 #33	1700 #33	1800 #33	2300 #33	2300 #33
Coil resistance (nominal)	60	60	65	85	85
Operating voltage	50 V.	50 V.	50 V.	50 V.	50 V.
Test voltage	37 V.	37 V.	32 V.	39 V.	37 V.
Extension spring load	GREEN	GREEN	GREEN	YELLOW	YELLOW
Sw actuator stroke	3/32	3/32	3/32	3/32	3/32
Additional information				THERMALEZE WIRE OR EQUIVALANT NO WRAP ON COIL.	
COIL NO.	C-7300-338	C-7300-338	C-7300-334	C-7300-336	C-7300-331

SPRING CODE

COLOR	PART NO.	LOAD
CLEAR	SP-199-13	13 OZ. AT $15/16$
BLUE	SP-199-14	21 OZ. AT $15/16$
YELLOW	SP-199-15	15 OZ. AT $15/16$
RED	SP-199-16	9 OZ. AT $15/16$
GREEN	SP-199-17	17 OZ. AT $15/16$

5 RELAYS BANK SWITCH CHART

FOR POSITION OF SWITCHES REFER TO PICTORIAL VIEW

RELAY SWITCH	LOCATION ON DIAGRAM	WIRE No.	WIRE COLORS	FUNCTION OF SWITCHES
4-5-6 YELLOW LINE RELAY COIL	A-31	40-3 70	Green Orange	Energized thru selections 4-5-6 search disc when scoring in yellow line of selections 4, 5 or 6.
A S.P.D.T.	E-35	53-2 71-6 52-2	White-Yellow Orange-Red White-Blue	Directs #4 score counter step-up circuit during white 4-in-line or yellow 3-in-line scoring in selection 4.
B S.P.D.T.	F-26	54-2 75-6 53-2	White-Green Orange-White White-Yellow	Directs #4 score counter step-up circuit during white 5-in-line or yellow 4-in-line scoring in selection 4.
C S.P.D.T.	E-27	53-2 51-6 52-2	White-Yellow White-Red White-Blue	Directs #5 score counter step-up circuit during white 4-in-line or yellow 3-in-line scoring in selection 5.
D S.P.D.T.	F-28	54-2 50-6 53-2	White-Green White White-Yellow	Directs #5 score counter step-up circuit during white 5-in-line or yellow 4-in-line scoring in selection 5.
E S.P.D.T.	E-28	53-2 56-6 52-2	White-Yellow White-Brown White-Blue	Directs #6 score counter step-up circuit during white 4-in-line or yellow 3-in-line scoring in selection 6.
F S.P.D.T.	F-29	54-2 63-6 53-2	White-Green Brown-Yellow White-Yellow	Directs #6 score counter step-up circuit during white 5-in-line or yellow 4-in-line scoring in selection 6.
1-2-3 YELLOW LINE RELAY COIL	A-24	57-2 70	White-Orange Orange	Energized thru selections 1-2-3 search disc when scoring in yellow line of selections 1, 2 or 3.
A S.P.D.T.	E-19	53-2 10-6 52-2	White-Yellow Red White-Blue	Directs #1 or yellow 3-in-line scoring in selection 1.
B S.P.D.T.	F-19	54-2 15-4 53-2	White-Green Red-White White-Yellow	Directs #1 score counter step-up circuit during white 5-in-line or yellow 4-in-line scoring in selection 1.
C S.P.D.T.	E-20	53-2 18-6 52-2	White-Yellow Red-Black White-Blue	Directs #2 score counter step-up circuit during white 4-in-line or yellow 3-in-line scoring in selection 2.
D S.P.D.T.	F-21	54-2 25-6 53-2	White-Green Blue-White White-Yellow	Directs #2 score counter step-up circuit during white 5-in-line or yellow 4-in-line scoring in selection 2.
E S.P.D.T.	E-22	53-2 27-6 52-2	White-Yellow Blue-Orange White-Blue	Directs #3 score counter step-up circuit during white 4-in-line or yellow 3-in-line scoring in selection 3.
F S.P.D.T.	F-22	54-2 38-6 53-2	White-Green Yellow-Black White-Yellow	Directs #3 score counter step-up circuit during white 5-in-line or yellow 4-in-line scoring in selection 3.
START RELAY COIL	A-6	98-3 70	Gray-Black Orange	Energized on each spin of game, thru coin switch, replay button switch, and also thru automatic selection step-up circuit.
A N.O.	E-6	57 81	White-Orange Black-Red	Lock-in circuit for this relay.
B N.O.	C-9	54 30	White-Green Yellow	Completes circuit to open shutter, and energize start cams index coil.

5 RELAYS BANK SWITCH CHART

FOR POSITION OF SWITCHES REFER TO PICTORIAL VIEW

RELAY SWITCH	LOCATION ON DIAGRAM	WIRE No.	WIRE COLORS	FUNCTION OF SWITCHES
ANTI-CHEAT RELAY COIL	A-5	51 70	White-Red Orange	Energized by control unit cam switch #5A, protect scoring, lite, and game playing circuits.
A N.O.	C-5	51 30	White-Red Yellow	Lock-in circuit for this relay.
B N.O.	L-6	14 15	Red-Green Red-White	Opens 17 volt circuit when this relay drops out.
C N.C.	E-8	74 75	Orange-Green Orange-White	Completes circuit to energize score reset relay when this relay drops out.
D N.C.	L-4	18 31-4	Red-Black Yellow-Red	Completes a circuit to lite tilt lite when this relay drops out.
E N.O.	L-4	31-4 41-5	Yellow-Red Green-Red	Opens circuit to score indicator lites when this relay drops out.
SCORE RESET RELAY COIL	A-8	75 70	Orange-White Orange	Energized thru score indicator unit 'O' switch, when anti-cheat relay drops out.
A N.O.	E-7	74 75	Orange-Green Orange-White	Lock-in circuit for this relay.
B N.O.	C-2	10P 20P	Red(Plastic) Blue(Plastic)	Completes a circuit to run control unit motor.
C N.C.	D-8	53 61-2	White-Yellow Brown-Red	Opens timer unit step-up circuit.
D N.C.	B-6	81 98-3	Black-Red Gray-Black	Opens start circuit.
E S.P.D.T.	C-7	91 93 83	Gray-Red Gray-Yellow Black-Yellow	Opens circuit to pulse score indicator unit escapement coil thru control unit cam switch #6B, and completes circuit to pulse coil thru control unit cam switch #3A.

MISCELLANEOUS RELAYS SWITCH CHART

RELAY SWITCH	LOCATION ON DIAGRAM	WIRE No.	WIRE COLORS	FUNCTION OF SWITCHES
TILT RESET COIL	B-13	85 70	Black-White Orange	Energized by shutter motor cam switch #2B, when starting new game. When this coil is energized, tilt relay coil drops out.
TILT RELAY COIL	A-5	J 70	Jumper Orange	Energized by tilt switches or plumb bob tilt. Also thru control unit cam switch #5D if coin switch is closed too long.
A N.C.	D-1	10P 50P	Red(Plastic) White(Plastic)	Opens circuit to control unit motor.
B N.C.	B-5	13-5 J	Red-Yellow Jumper	Opens circuit to tilt relay coil.
C N.C.	M-6	10 15	Red Red-White	Opens 17 volt circuit.
D N.O.	L-4	18 31-4	Red-Black Yellow-Red	Completes a circuit to tilt lite.
E S.P.D.T.	H-8	60-1 30 38-2	Brown Yellow Yellow-Black	Opens timer step-up circuit, and search circuit, and completes circuit to close shutter if game is tilted when shutter is open.
BALL GATE RELAY COIL	A-10	98 70	Gray-Black Orange	Energized by shutter motor cam switch 2A when starting new game. Relay stays energized until 1st ball is shot.
A N.O.	E-10	71 98	Orange-Red Gray-Black	Lock-in circuit for this relay.
B N.C.	H-9	61 30	Brown-Red Yellow	In series with circuit to close shutter when 1st ball is shot.

NEW ANTI-CHEAT COIN SWITCH CIRCUIT

The coin switch gives a very short pulse, when operated by a coin. With this new circuit, the game will tilt if the pulse is not as short as from a coin, so that operating the coin switch with wire, strings, etc., usually results in a tilt.

The circuit is completed thru control unit cam switch #5D (on wiring diagram at D-6).

MOTOR ASSEMBLY (Part No. E-119-212)

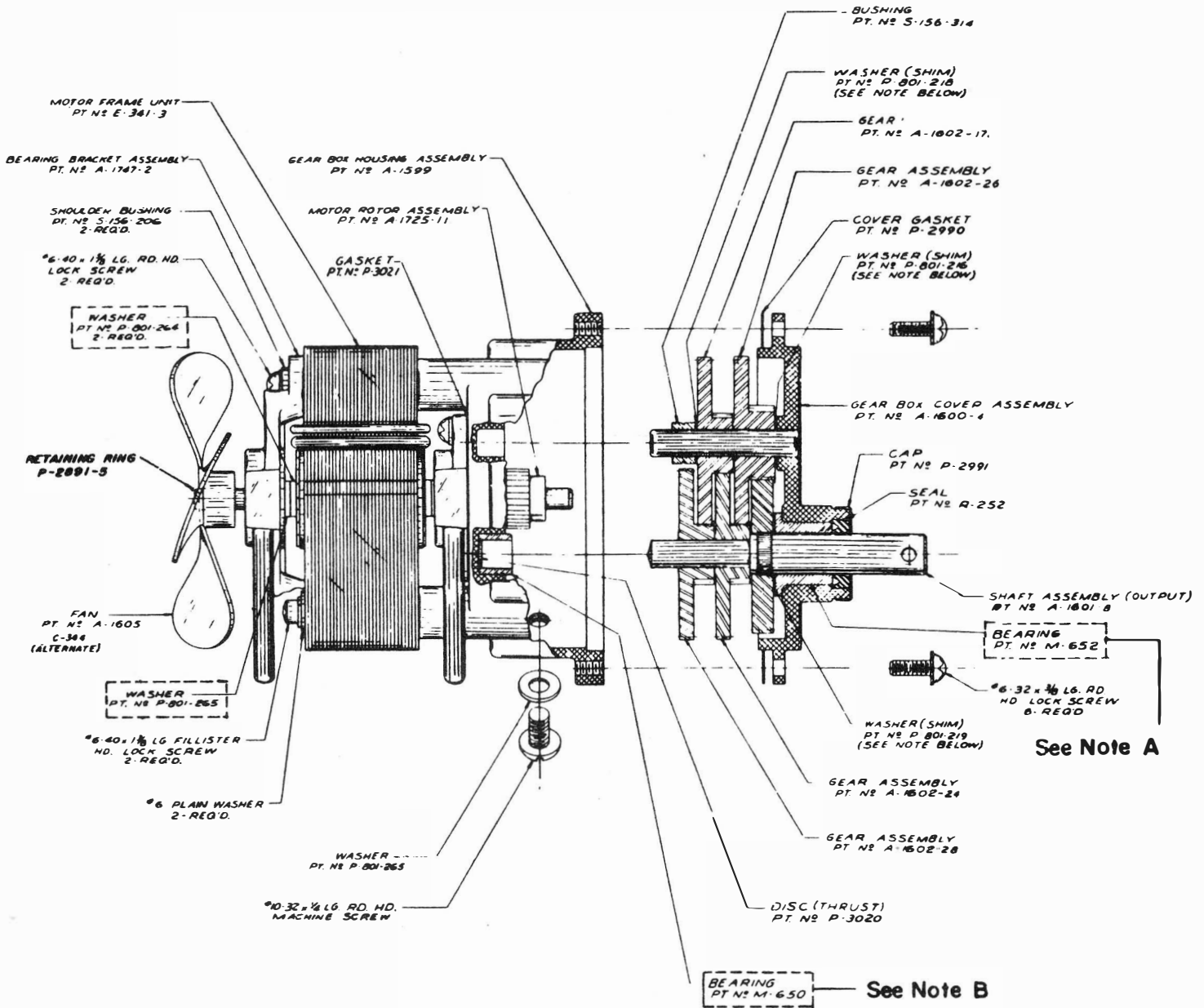

See Note A

See Note B

NOTE
 IN ORDER TO MAINTAIN PROPER CLEARANCES BETWEEN GEARS IT IS MOST IMPORTANT THAT WHEN REASSEMBLING GEAR TRAIN:
 1. SHIMS BE REPLACED IN THEIR RESPECTIVE LOCATIONS
 2. SAME NUMBER OF SHIMS BE REPLACED IN EACH RESPECTIVE LOCATION.

NOTE A: Bearing M-652 is part of Gear Box Cover Assembly A-1600-4 and cannot be ordered separately.

NOTE B: Bearing M-650 is part of Gear Box Housing Assembly A-1599 and cannot be ordered separately.

NOTES

MISCELLANEOUS PARTS

Back Cabinet Assembly:

Part No.	Name of Part
G-303-6	Back glass—FUN SPOT—62
G-303-5	Back glass—BARREL O'FUN—62
M-281-23	Lock and keys (2) Keyed alike

Back Door Assembly:

M-281-25	Lock and keys
P-758-17	Lock cam
E-122-19	Transformer

Front Cabinet Assembly:

M-168-15	Ball
AS-187-18	Ball shooter assembly
A-1540-3	Ball shooter housing
A-100-7	Ball shooter rod
SP-200-24	Ball shooter spring (long)
SP-243	Ball shooter spring (short)
R-108-3	Ball shooter tip
P-711-1	Cigarette holder
P-2210-80	Coin entry plate 10¢
P-2210-81	Coin entry plate 5¢
P-1900-49	Coin box—Front door
P-1900-50	Coin box—Side door
CA-1088-2	Front moulding only
M-281-22	Lock and keys—side door
A-2618	Leg
M-106-1	Leg bolt
M-163-4	Leg adjuster
CA-1088-3	Side door only

Front Door Assembly:

Part No.	Name of Part
A-1538-3	Armature plate (AS-277-56)
E-101-45	Coil—coin lockout
AS-277-56	Coin switch assembly 5¢ and 10¢
CA-567-128	Front door only—FUN SPOT—62
CA-567-126	Front door only— BARREL O'FUN—62
AS-1971-7	Front door assembly complete— FUN SPOT—62
AS-1971-8	Front door assembly complete— BARREL O'FUN—62
A-254-33	Hinge and bracket
M-281-6	Lock and keys
P-4005	Lock cam
E-108-32	Micro switch 5¢ and 10¢
A-1729-6	Push button—Replay
SW-100-157	Push button switch
P-2768-5	Ring for A-1729-6 button
P-2768-7	Ring for M-281-6 lock
M-280-15	Slug rejector 5¢
M-280-16	Slug rejector 10¢

Panel Assembly:

AS-1315	Ball Gate and Switch Assembly
C-326-9	Light Shield post
R-115-4	Rebound Rubber
M-170	Rebound spring—double post
R-243	Rubber ring for yellow post
R-243-2	Rubber ring for red post

Bally pin game lubricant now available in one half-pint
(8 Oz.) containers with plastic spout and screw cap.