

Operating Instructions and Parts Catalog

CONFIDENTIAL: DO NOT LEAVE INSTRUCTIONS IN GAME

Bally®

BEACH CLUB



BEACH CLUB by Bally

Replay amusement game

5 balls 5 cents

EXTRA COINS MAY BE PLAYED

(A) FOR SCORING ADVANTAGES

(B) FOR EXTRA BALLS

IN-LINE SCORES: Card on backglass contains 25 numbers, 1 to 25, arranged in a square 5 numbers wide by 5 numbers high, not in numerical order.

Each of 2 Super-Cards on backglass contains 9 numbers, duplicating numbers on Card, arranged in a square 3 numbers wide by 3 numbers high, not in numerical order.

Playfield contains 25 skill-holes, numbered 1 to 25 in numerical order, from top to bottom of playfield, and ball-return hole through which balls return for free shots.

Object of game is to shoot 5 balls (and extra balls) into numbered skill-holes

- (A) To light 3, 4 or 5 adjoining numbers, connected---horizontally, vertically or diagonally---by white line on Card;
- (B) To light 3 adjoining numbers, connected---horizontally, vertically or diagonally---by white line on a Super-Card, when corresponding SUPER-CARD panel is lit on backglass (see SUPER-CARDS on page 82).

In-line scores are listed under ADVANCING SCORES on page 83.

CORNERS-SCORES: Further object of game is

- (A) To light 4 corner-numbers of Card, when Corners-Panel is lit (see CORNERS-PANEL on page 83), scoring 200;
- (B) To light 4 corner-numbers of a Super-Card, when corresponding SUPER-CARD panel is lit (see SUPER-CARDS on page 82), scoring 300.

SELECT-A-SPOT FEATURE: Arrows above Selection-Numbers on backglass flash, when coins* are deposited, and advance at mystery-intervals. When light advances to fourth arrow,

- (A) Selection-Numbers light (see GUARANTEED SELECTIONS on page 82),
- (B) Panel with words "SELECT A LIT NUMBER" lights, notifying player that player's choice of lit Selection-Number may be lit on Card and Super-Cards** by turning Selector-Knob on front of cabinet,

(continued on next page)

* When replays are registered, Buttons are pressed, instead of coins being deposited.

** 19, 20, 21, 22 and 16 appear on Card only, not on Super-Cards; 25 appears on Card and left Super-Card; 10 appears on Card and right Super-Card.

- (C) Panel with words "SELECT BEFORE SHOOTING 4th BALL" lights, notifying player that Selector-Knob locks*** after fourth ball is shot ---unless extra selection-time is indicated, as explained under EXTRA SELECTION-TIME below.

Scoring-advantages described directly above remain lit during entire game, but panel with words "SELECT BEFORE SHOOTING 4th BALL" may be cancelled by lighting panel with words "SELECT BEFORE SHOOTING 5th BALL", as explained under EXTRA SELECTION-TIME below.

After lighting scoring-advantages described above, player may deposit additional coins* to light additional scoring-advantages.

GUARANTEED SELECTIONS: First 4 Selection-Numbers---19, 20, 21, 22---always light when fourth Arrow lights above Selection-Numbers; at mystery-intervals additional Selection-Numbers---16, 25 and 10---light when guaranteed first 4 numbers light.

EXTRA SELECTIONS: After lighting first group of Selection-Numbers, player may deposit additional coins* to light additional Selection-Numbers and other scoring-advantages.

Each Selection-Number lighted remains lit during entire game.

After lighting all Selection-Numbers, player may deposit additional coins* to light other scoring-advantages.

EXTRA SELECTION-TIME: After lighting first 4 Selection-Numbers and panel with words "SELECT BEFORE SHOOTING 4th BALL", player may deposit additional coins* to light panel with words "SELECT BEFORE SHOOTING 5th BALL"---to delay locking*** Selector-Knob until after fifth ball is shot.

When lighted, panel with words "SELECT BEFORE SHOOTING 5th BALL" remains lit during entire game, and player may deposit additional coins* to light other scoring-advantages.

TRIPLE-SPOTS FEATURE: 2 Stars on backglass and playfield flash for each coin* deposited and, at mystery-intervals, light and remain lit during entire game.

Player who hits Star-Rollover, when corresponding Star is lit, lights 2, 5 and 8 on Card---all 3 numbers.

After lighting Stars, player may deposit additional coins* to light other scoring-advantages.

SUPER-CARDS: Panel with word SUPER-CARD above each Super-Card flashes for each coin* deposited and, at mystery-intervals, lights and remains lit during entire game, qualifying player for in-line scores and corners-scores on Super-Card with corresponding SUPER-CARD panel lit.

(continued on next page)

* When replays are registered, Buttons are pressed, instead of coins being deposited.

*** Warning panel with words "SELECT NOW" lights after third ball is shot, if panel with words "SELECT BEFORE SHOOTING 4th BALL" is lit, or lights after fourth ball is shot, if panel with words "SELECT BEFORE SHOOTING 5th BALL" is lit.

After lighting one SUPER-CARD panel, player deposited additional coins* to light second SUPER-CARD panel and other scoring-advantages.

CORNERS-PANEL: Panel with words "CENTER CARD CORNERS SCORE 200" flashes for each coin* deposited and, at mystery-intervals, lights and remains lit during entire game, qualifying players for corners-score on Card.

After lighting CORNERS-PANEL, player may deposit additional coins* to light other scoring-advantages.

ADVANCING SCORES****: Scores**** appear in beach-scene on backglass, advancing at mystery-intervals.

GUARANTEED SCORES****: Scores**** either advance to a higher bracket or remain as high as on previous coin*, never drop back to a lower bracket, regardless of number of coins* deposited.

After advancing scores to highest bracket, player may deposit additional coins* to light additional scoring-advantages.

EXTRA-BALLS FEATURE: After shooting 5 balls, player may press Extra-Balls Button and deposit additional coins* to play for extra balls.

At mystery-intervals, after Extra-Balls Button is pressed, (1st) lights on backglass, when coin* is deposited. After (1st) is lit, light advances, at mystery-intervals, to (EXTRA), when Extra-Balls Button is pressed and coin* is deposited. After (1st) (EXTRA) is lit, light advances, at mystery-intervals, to (BALL), when Extra-Balls Button is pressed and coin* is deposited.

When (1st) (EXTRA) (BALL) is completely lit, first extra ball is released to player.

After shooting first extra ball, player may continue to press Extra-Balls Button and deposit additional coins* to light (2nd) (EXTRA) (BALL) in order to receive second extra ball and to light (3rd) (EXTRA) (BALL) in order to receive third extra ball.

Coins* deposited to play for extra balls do not light other scoring-advantages.

After playing for extra balls, player may not play to light other scoring-advantages.

* When replays are registered, Buttons are pressed, instead of coins being deposited.

**** Card Scores

5-in-line: 96 - 96 - 100 - 100 - 150 - 150 - 192 - 300

4-in-line: 16 - 20 - 24 - 32 - 48 - 72 - 100 - 200

3-in-line: 4 - 6 - 8 - 12 - 18 - 36 - 48 - 64

**** Super-Card Scores

3-in-line on a Super-Card, when corresponding SUPER-CARD panel is lit, scores 4-in-line scores

Only 1 4-in-line score registers per game. Only highest in-line score registers. Only highest corners-score registers.

BEACH CLUB

INSTALLATION AND OPERATING INSTRUCTIONS

Fasten 4 legs to cabinet with bolts and washers furnished. Place back-box in position. Unlock and open back-door and fasten the back-box to cabinet with bolts and washers furnished. (2 back-door locks are common.)

Plug power line into 110-115 volt 60 cycle Alternating Current only. Turn on power by turning toggle-switch on. Toggle-switch is located on lower left side of back-box.

ACCESS TO MECHANISM AND LIGHT BULBS

Back-glass may be removed from either side by unlocking side desired and removing upright moulding. (Remove moulding by pulling bottom portion.)

After removing back-glass, access to mechanism may be obtained by raising 2 slide brackets on insert, located on left and right edges of insert. Insert may then be tilted forward for easy accessibility.

BE SURE TO LEVEL GAME

See instructions for leveling below.

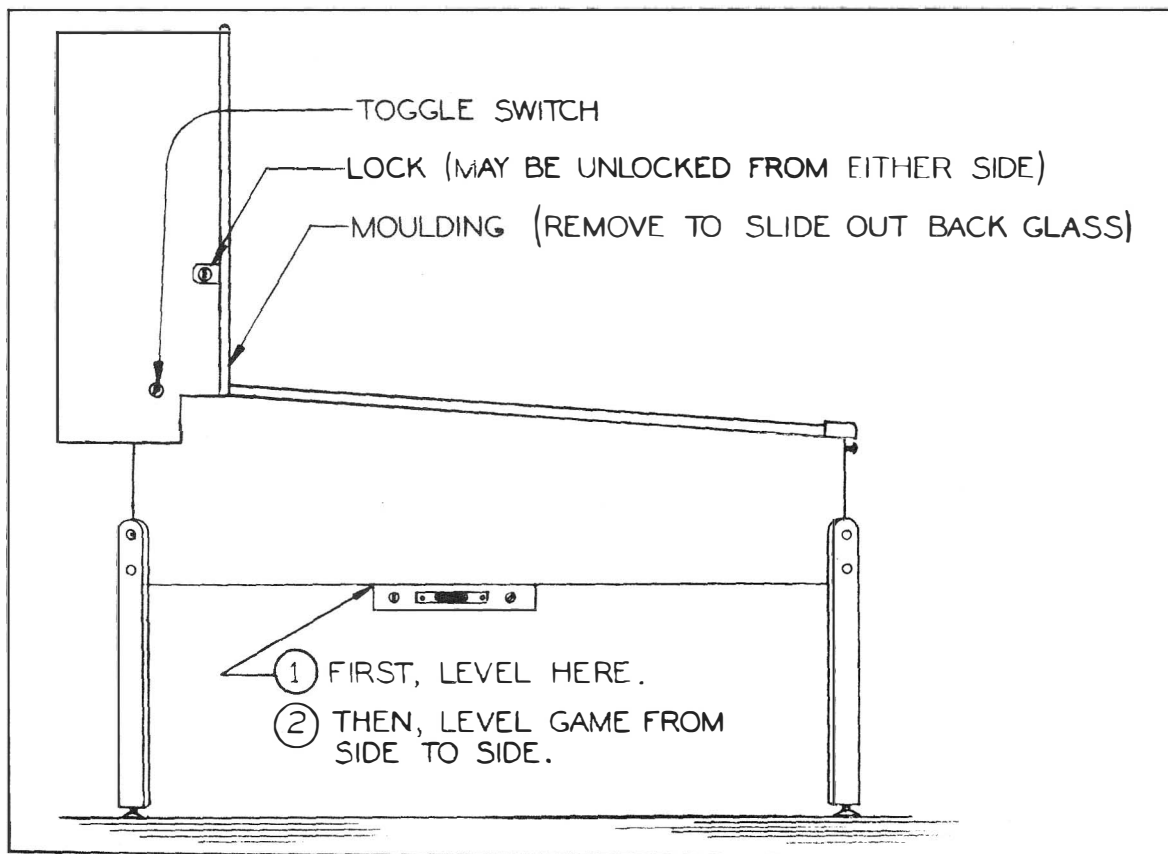

NOTES

**BEACH CLUB
TIMER UNIT — COIL SIDE**

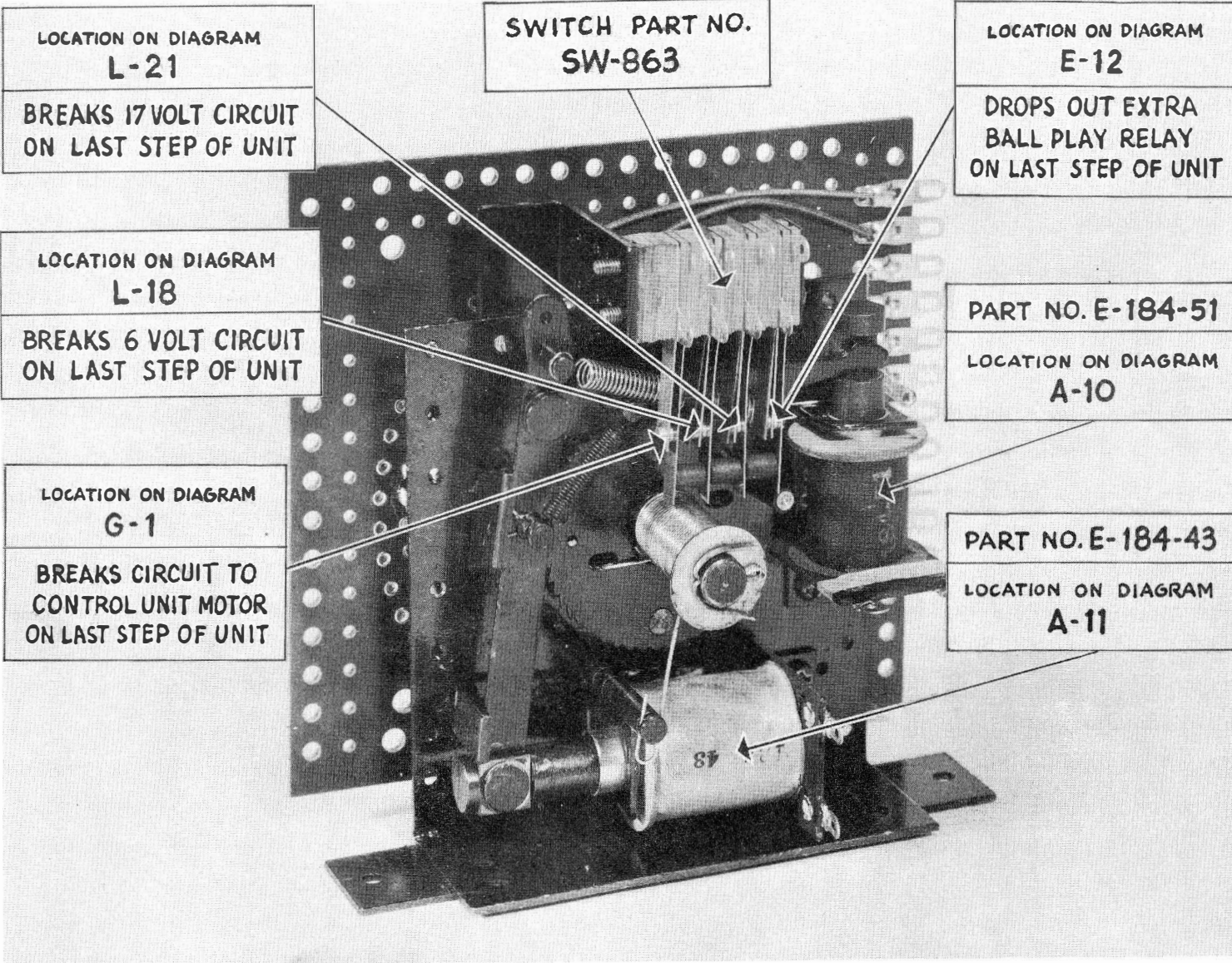

BEACH CLUB TIMER UNIT — WIPER SIDE

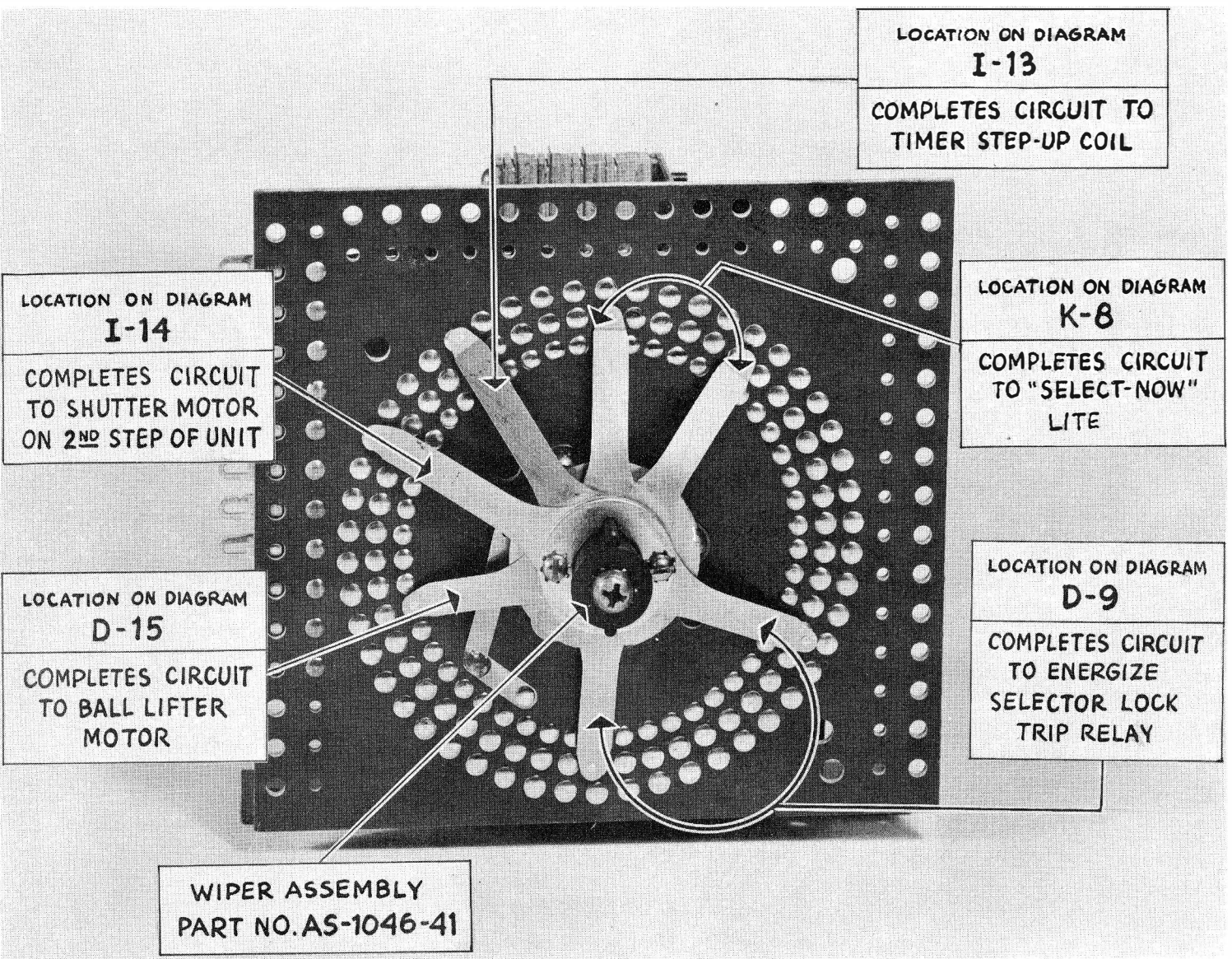

BEACH CLUB
ODDS UNIT — COIL SIDE

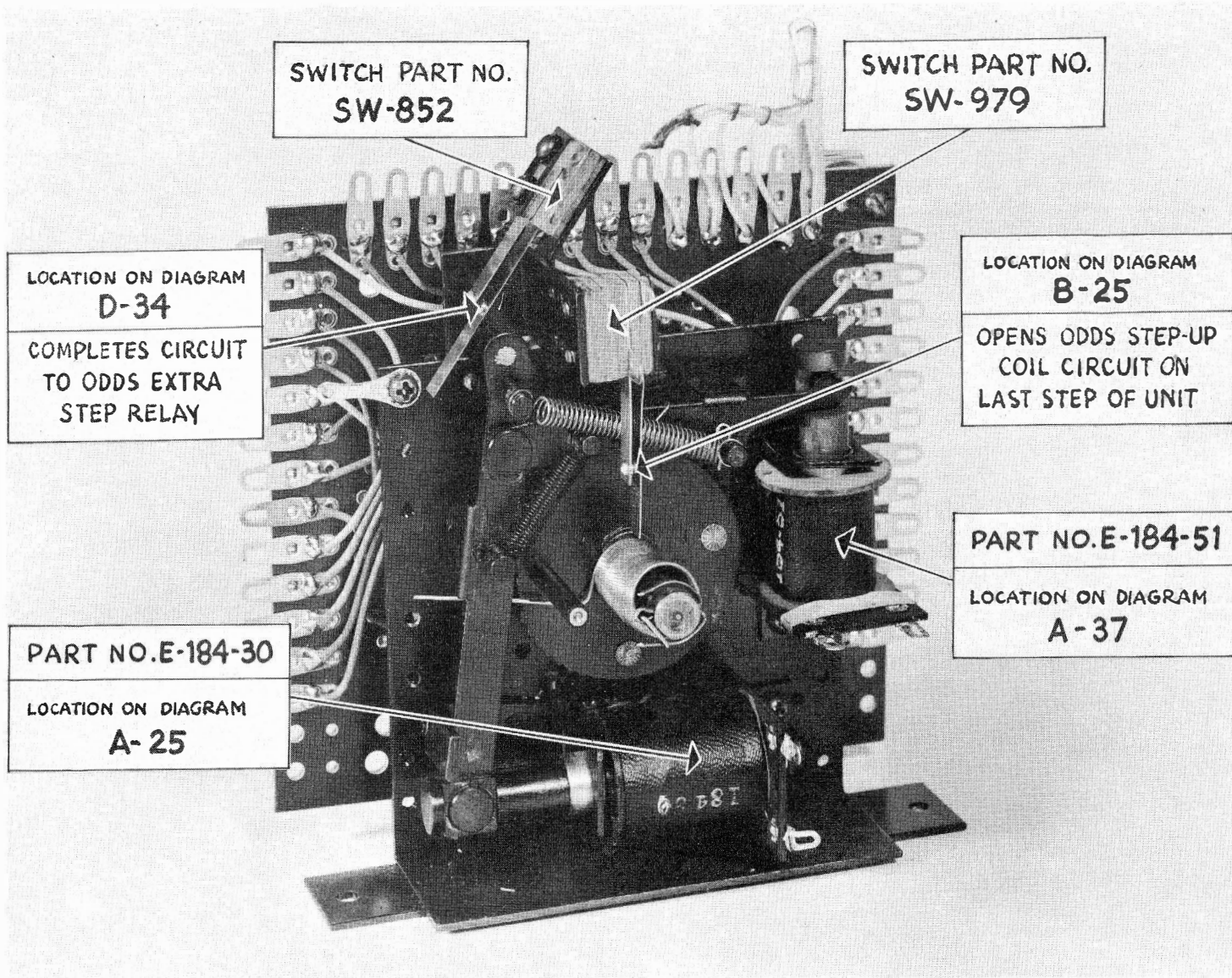

BEACH CLUB
ODDS UNIT — WIPER SIDE

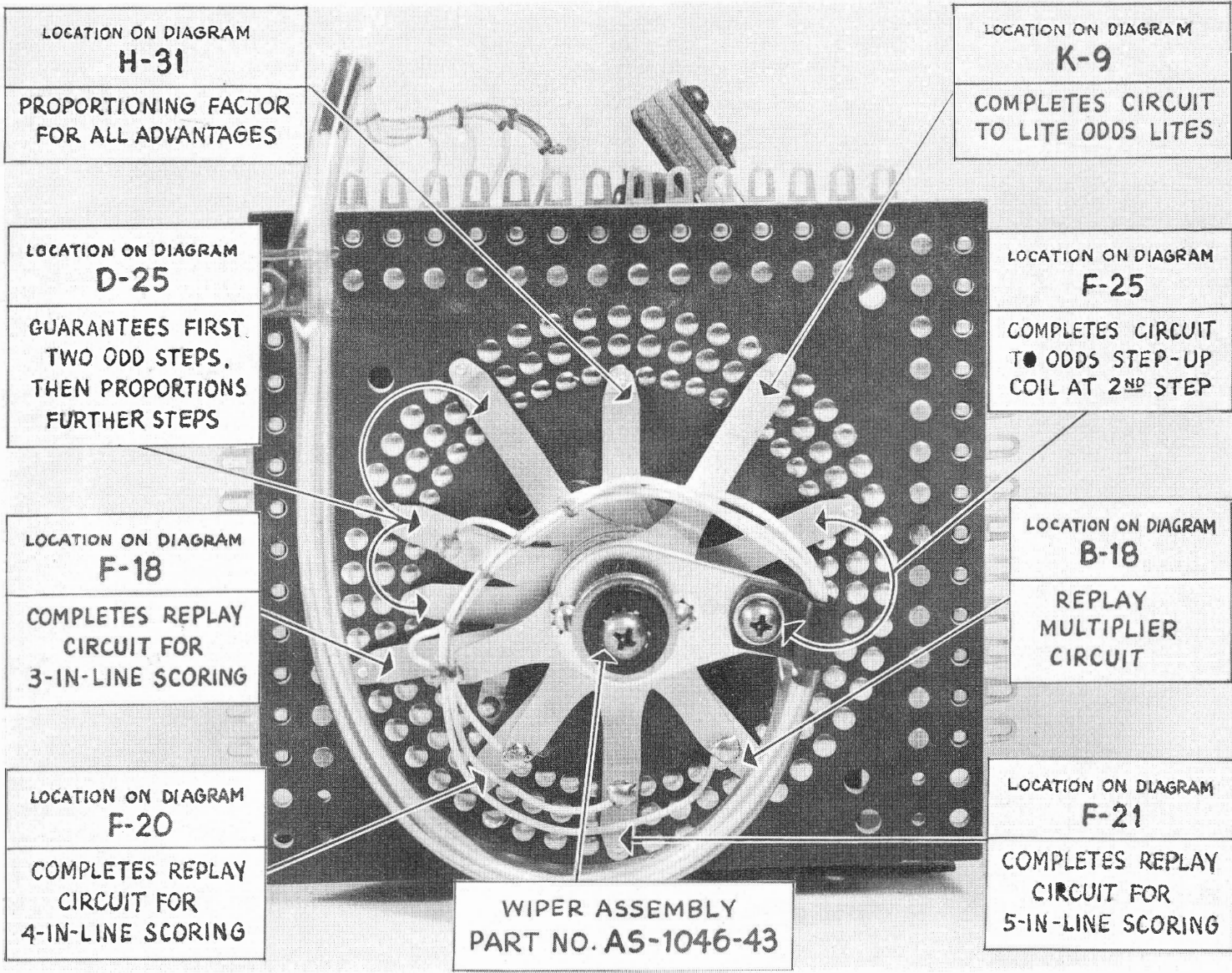

LOCATION ON DIAGRAM
H-31
 PROPORTIONING FACTOR
 FOR ALL ADVANTAGES

LOCATION ON DIAGRAM
K-9
 COMPLETES CIRCUIT
 TO LITE ODDS LITES

LOCATION ON DIAGRAM
D-25
 GUARANTEES FIRST
 TWO ODD STEPS,
 THEN PROPORTIONS
 FURTHER STEPS

LOCATION ON DIAGRAM
F-25
 COMPLETES CIRCUIT
 TO ODDS STEP-UP
 COIL AT 2ND STEP

LOCATION ON DIAGRAM
F-18
 COMPLETES REPLAY
 CIRCUIT FOR
 3-IN-LINE SCORING

LOCATION ON DIAGRAM
B-18
 REPLAY
 MULTIPLIER
 CIRCUIT

LOCATION ON DIAGRAM
F-20
 COMPLETES REPLAY
 CIRCUIT FOR
 4-IN-LINE SCORING

LOCATION ON DIAGRAM
F-21
 COMPLETES REPLAY
 CIRCUIT FOR
 5-IN-LINE SCORING

**WIPER ASSEMBLY
 PART NO. AS-1046-43**

BEACH CLUB

EXTRA BALL UNIT — COIL SIDE

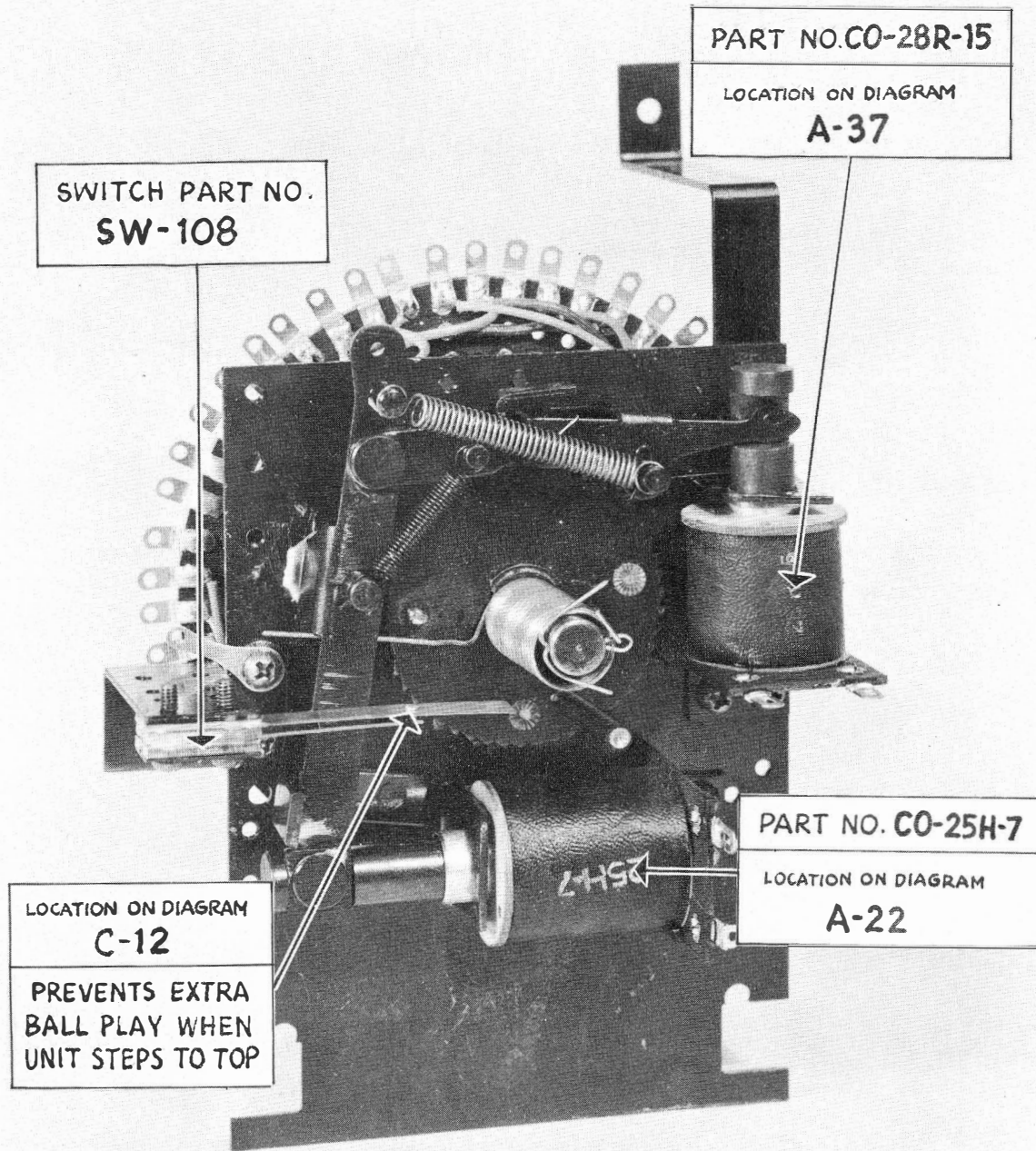

BEACH CLUB

EXTRA BALL UNIT — WIPER SIDE

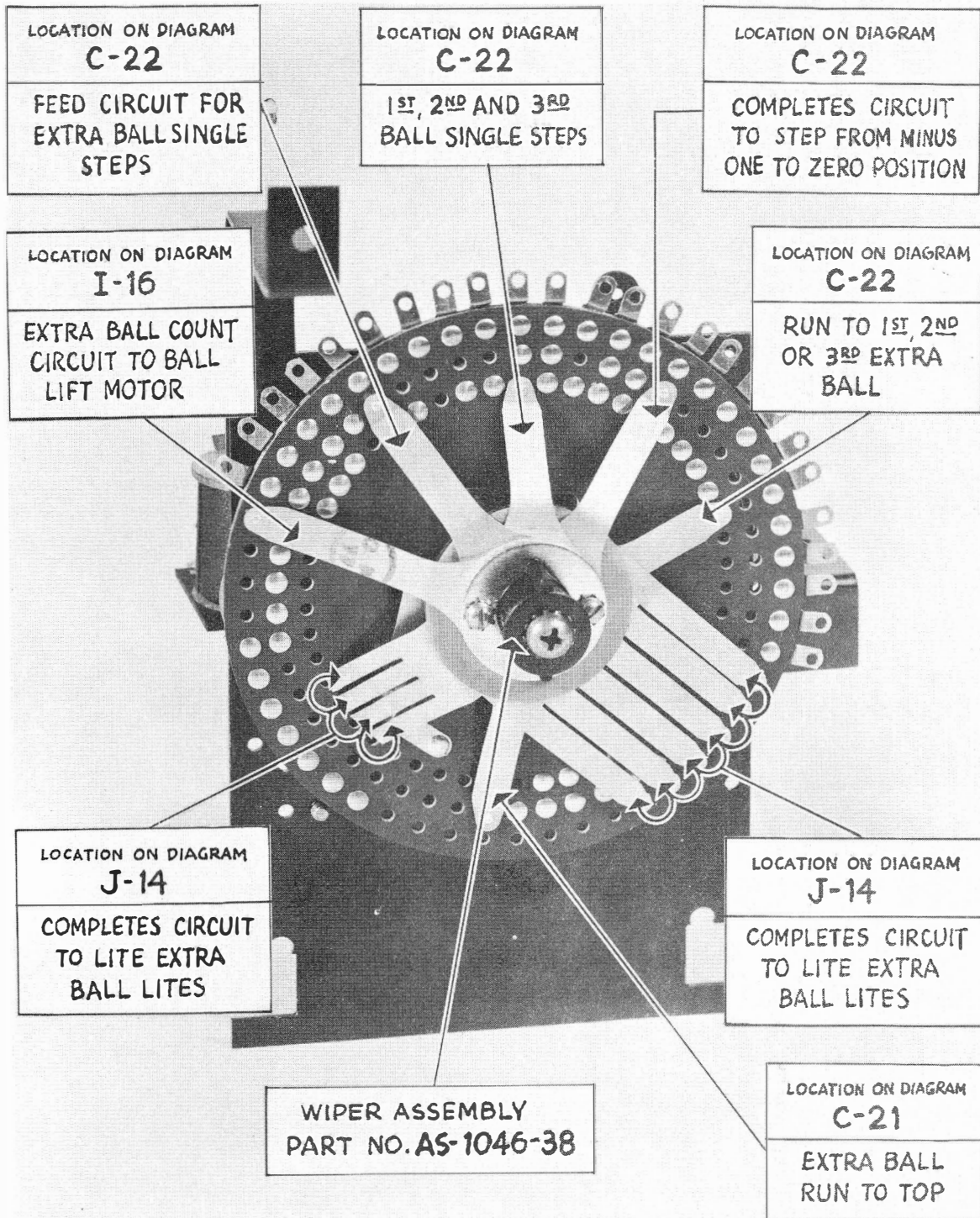

BEACH CLUB

REPLAY COUNTER — COIL SIDE

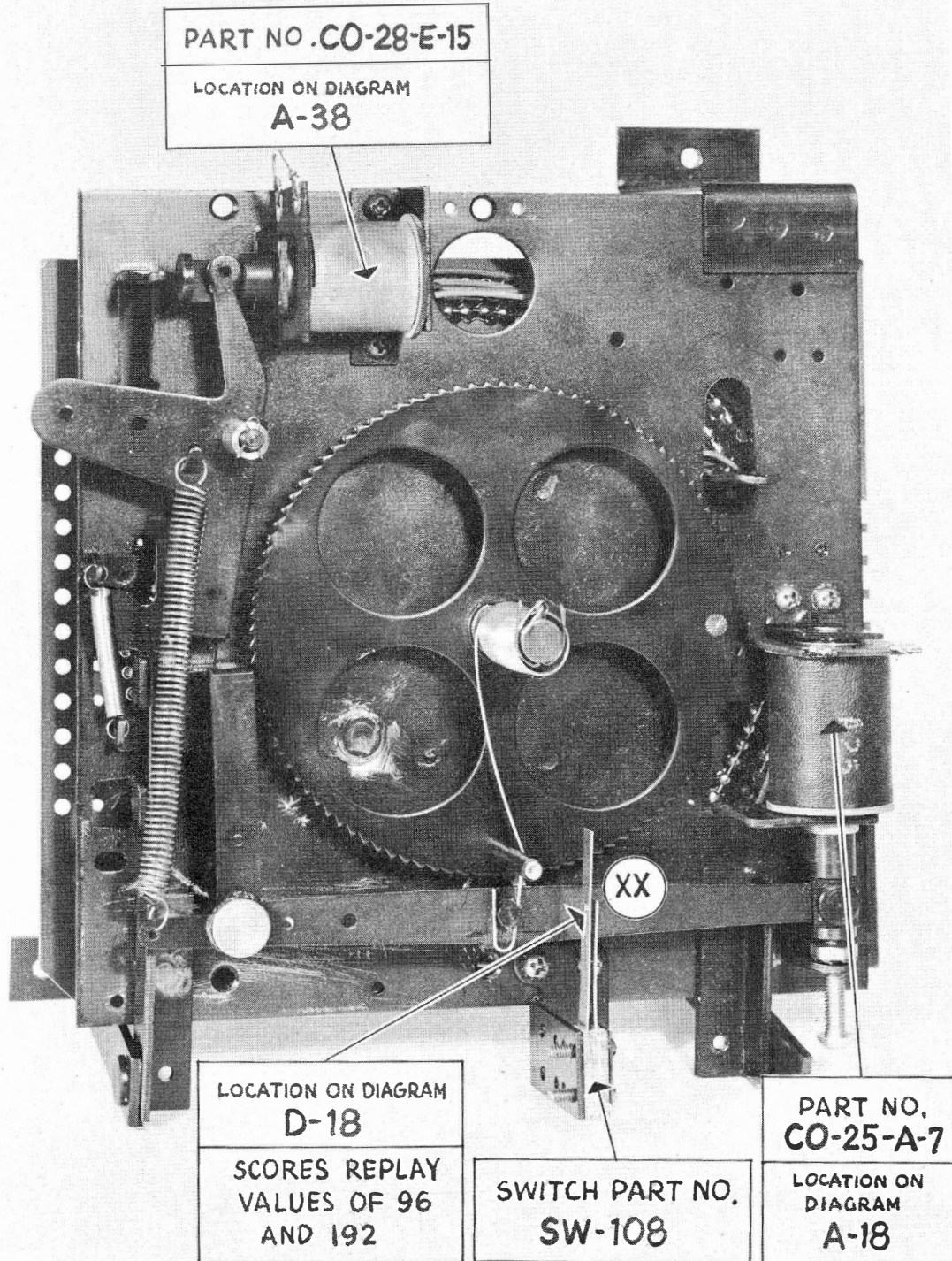

BEACH CLUB

REPLAY COUNTER — WIPER SIDE

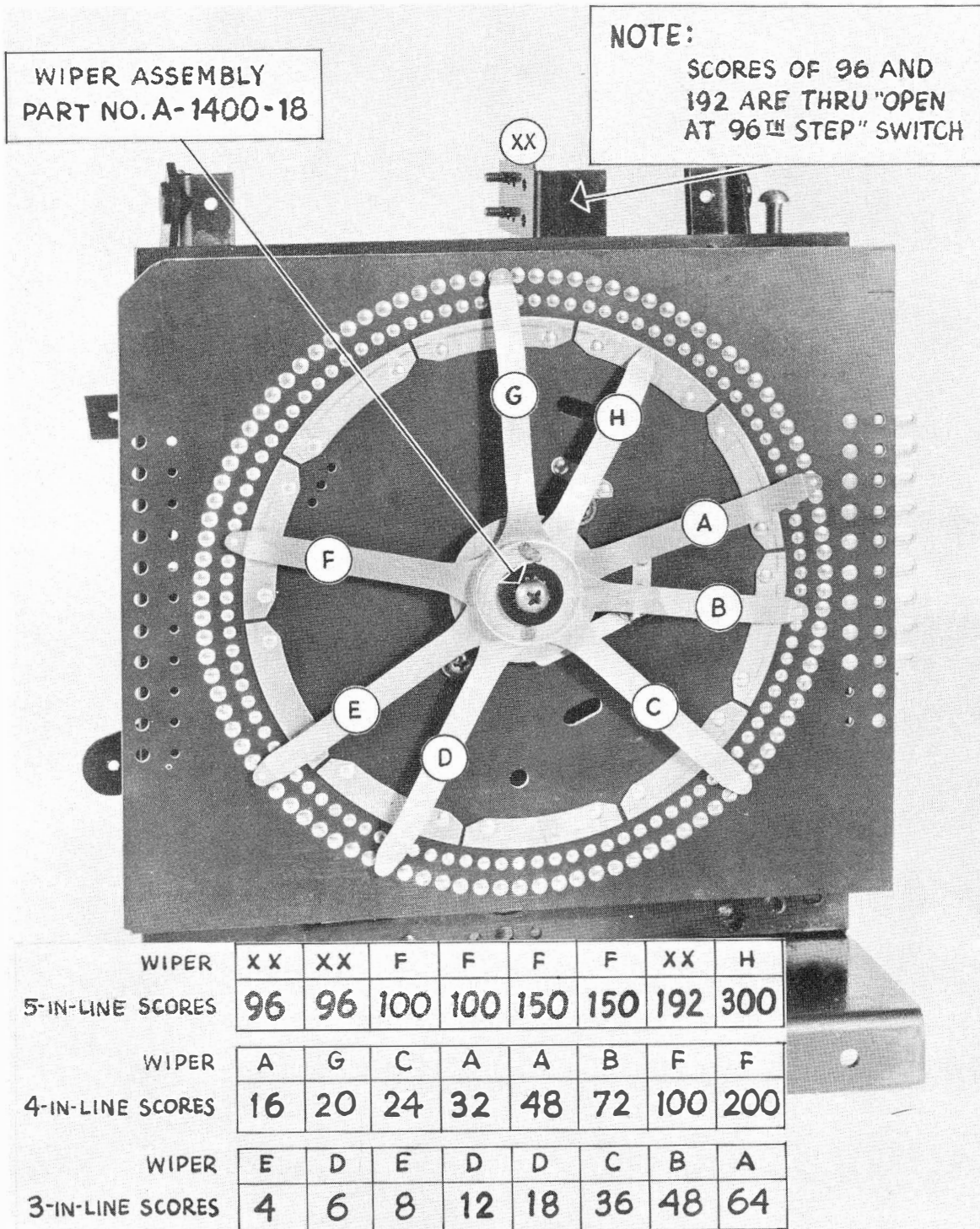

WIPER	XX	XX	F	F	F	F	XX	H
5-IN-LINE SCORES	96	96	100	100	150	150	192	300
WIPER	A	G	C	A	A	B	F	F
4-IN-LINE SCORES	16	20	24	32	48	72	100	200
WIPER	E	D	E	D	D	C	B	A
3-IN-LINE SCORES	4	6	8	12	18	36	48	64

BEACH CLUB

SELECTION FEATURE UNIT — COIL SIDE

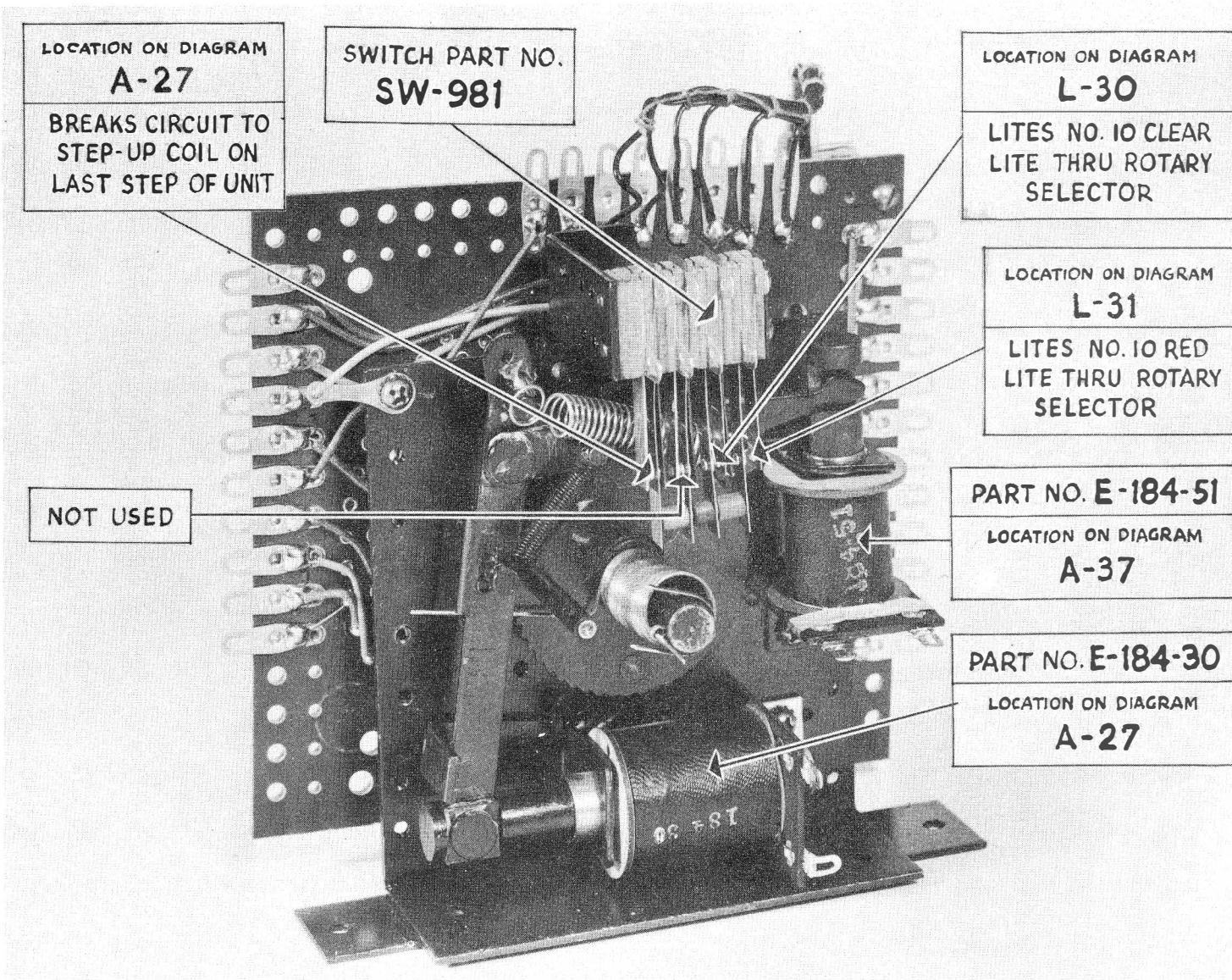

LOCATION ON DIAGRAM
A-27
BREAKS CIRCUIT TO
STEP-UP COIL ON
LAST STEP OF UNIT

SWITCH PART NO.
SW-981

LOCATION ON DIAGRAM
L-30
LITES NO. 10 CLEAR
LITE THRU ROTARY
SELECTOR

LOCATION ON DIAGRAM
L-31
LITES NO. 10 RED
LITE THRU ROTARY
SELECTOR

NOT USED

PART NO. **E-184-51**
LOCATION ON DIAGRAM
A-37

PART NO. **E-184-30**
LOCATION ON DIAGRAM
A-27

BEACH CLUB SELECTION FEATURE UNIT — WIPER SIDE

LOCATION ON DIAGRAM
K-1
LITES "SELECT A
LIT NUMBER"
ARROW LITES

LOCATION ON DIAGRAM
L-29
LITES NO. 16 CLEAR
LITE THRU ROTARY
SELECTOR

LOCATION ON DIAGRAM
K-7
COMPLETES CIRCUIT
TO LITE SELECTION
FEATURE LITES

LOCATION ON DIAGRAM
L-29
LITES NO. 25 CLEAR
LITE THRU ROTARY
SELECTOR

LOCATION ON DIAGRAM
H-25
PROPORTIONING
FACTOR FOR EXTRA
BALL STEPS, ALSO
ODDS STEPS

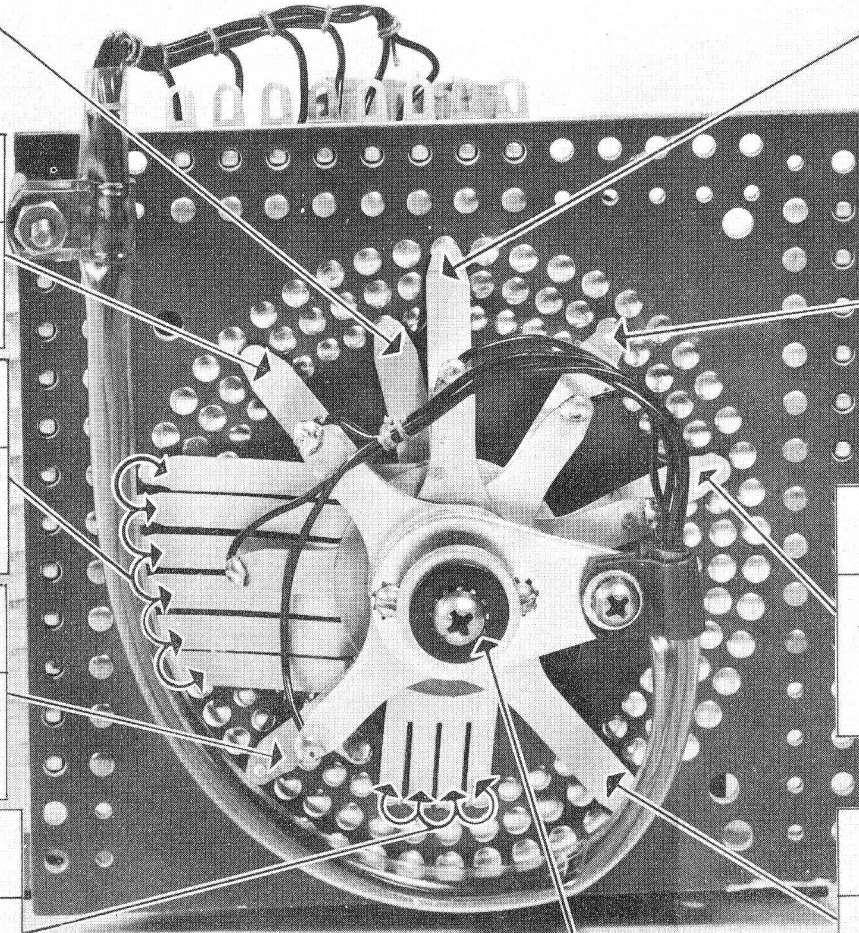

WIPER ASSEMBLY
PART NO. AS-1046-44

LOCATION ON DIAGRAM
L-28
LITES NO. 16 RED
LITE THRU ROTARY
SELECTOR

LOCATION ON DIAGRAM
L-28
LITES NO. 25 RED
LITE THRU ROTARY
SELECTOR

LOCATION ON DIAGRAM
D-27
COMPLETES CIRCUIT
TO SELECTION FEATURE
STEP-UP COIL FOR
MULTIPLE STEPS

LOCATION ON DIAGRAM
D-28
COMPLETES CIRCUIT
TO SELECTION FEATURE
STEP-UP COIL FOR
SINGLE STEPS

BEACH CLUB

SEARCH DISC AND WIPERS

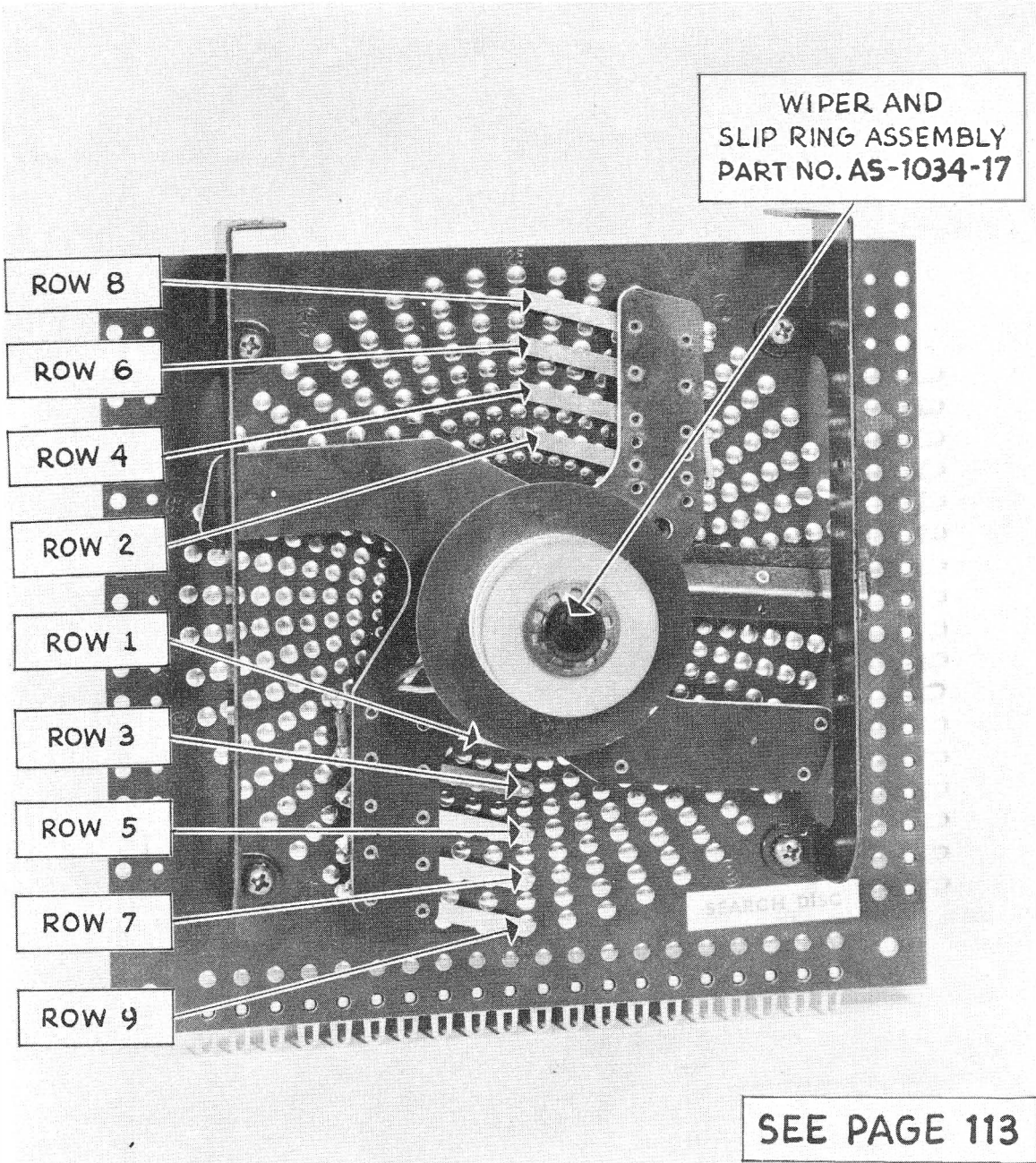

BEACH CLUB

CONTROL UNIT SPOTTING DISC AND WIPERS

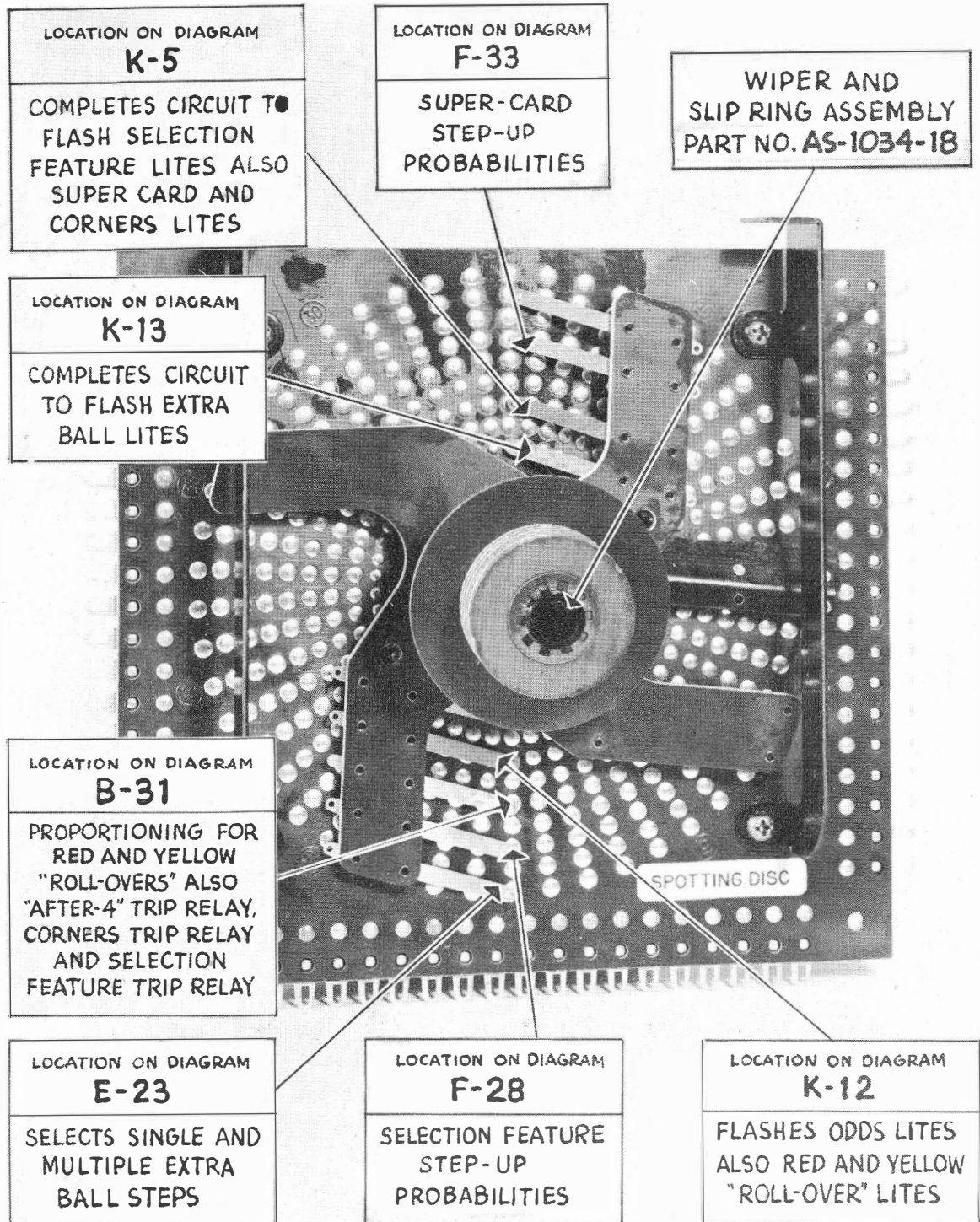

**BEACH CLUB
SUPER-CARD UNIT — COIL SIDE**

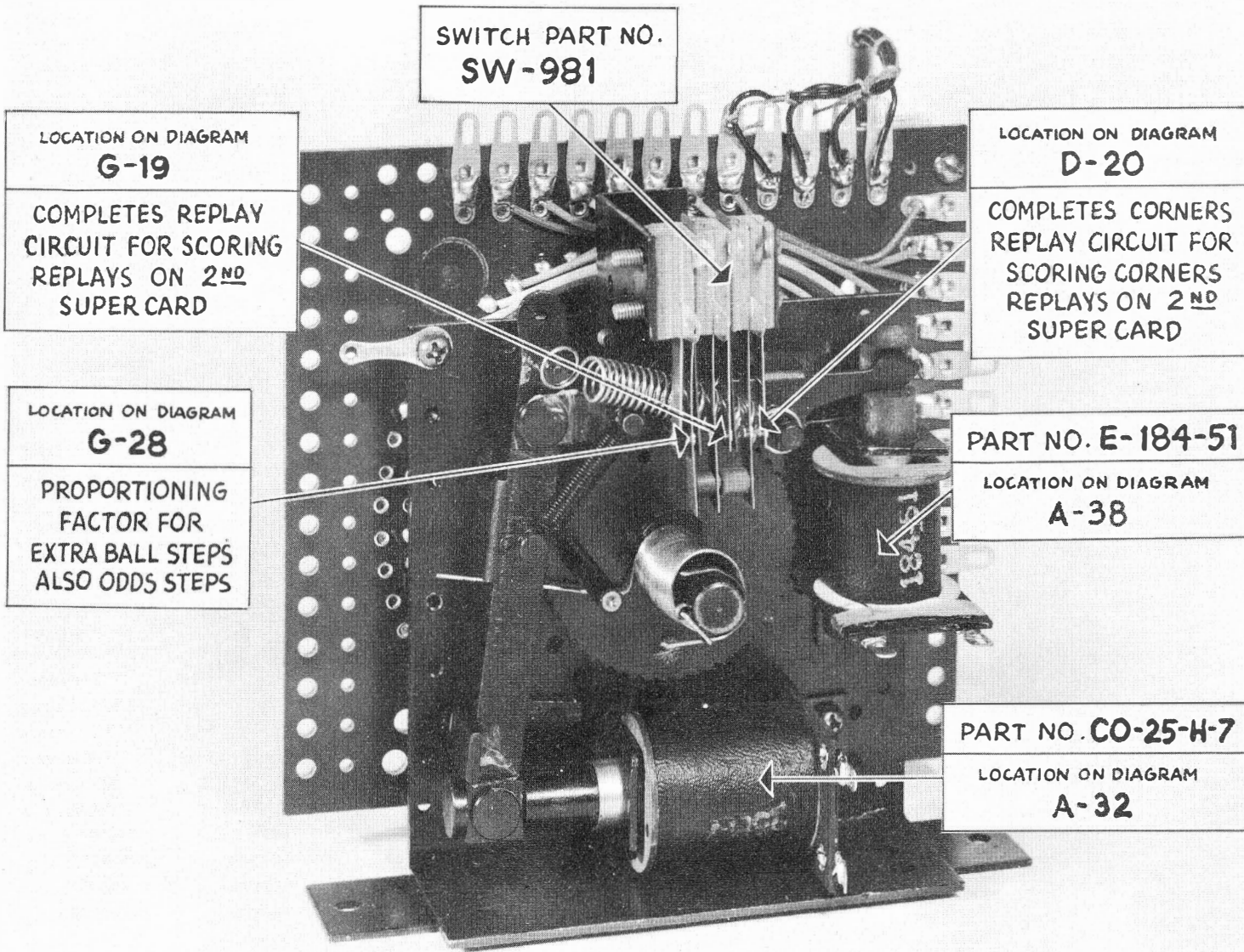

SWITCH PART NO.
SW-981

LOCATION ON DIAGRAM
G-19
COMPLETES REPLAY
CIRCUIT FOR SCORING
REPLAYS ON 2ND
SUPER CARD

LOCATION ON DIAGRAM
D-20
COMPLETES CORNERS
REPLAY CIRCUIT FOR
SCORING CORNERS
REPLAYS ON 2ND
SUPER CARD

LOCATION ON DIAGRAM
G-28
PROPORTIONING
FACTOR FOR
EXTRA BALL STEPS
ALSO ODDS STEPS

PART NO. **E-184-51**
LOCATION ON DIAGRAM
A-38

PART NO. **CO-25-H-7**
LOCATION ON DIAGRAM
A-32

**BEACH CLUB
SUPER-CARD UNIT — WIPER SIDE**

LOCATION ON DIAGRAM
D-19
COMPLETES CORNERS
REPLAY CIRCUIT FOR
SCORING CORNERS
REPLAYS ON FIRST
SUPER CARD

LOCATION ON DIAGRAM
D-34
COMPLETES CIRCUIT
TO SUPER CARD
STEP-UP COIL
FOR SINGLE STEPS

LOCATION ON DIAGRAM
C-32
COMPLETES CIRCUIT
FOR SUPER CARD
MULTIPLE STEPS

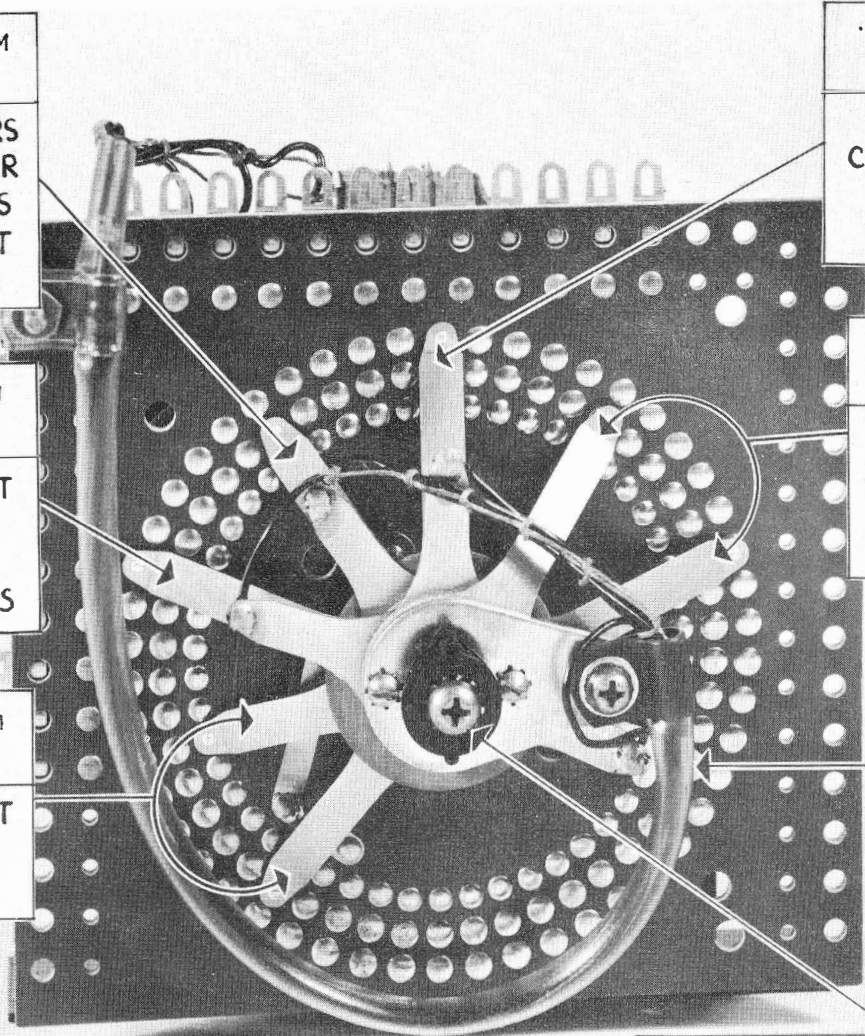

LOCATION ON DIAGRAM
G-19
COMPLETES REPLAY
CIRCUIT FOR SCORING
REPLAYS ON FIRST
SUPER CARD

LOCATION ON DIAGRAM
K-2
COMPLETES CIRCUIT
TO LITE SUPER CARD
AND SUPER CARD
ARROW LITES

LOCATION ON DIAGRAM
I-28
PROPORTIONING
FACTOR FOR
EXTRA BALL STEPS
ALSO ODDS STEPS

WIPER ASSEMBLY
PART NO. **AS-1046-45**

NOTES

**BEACH CLUB
CORNERS REPLAY COUNTER**

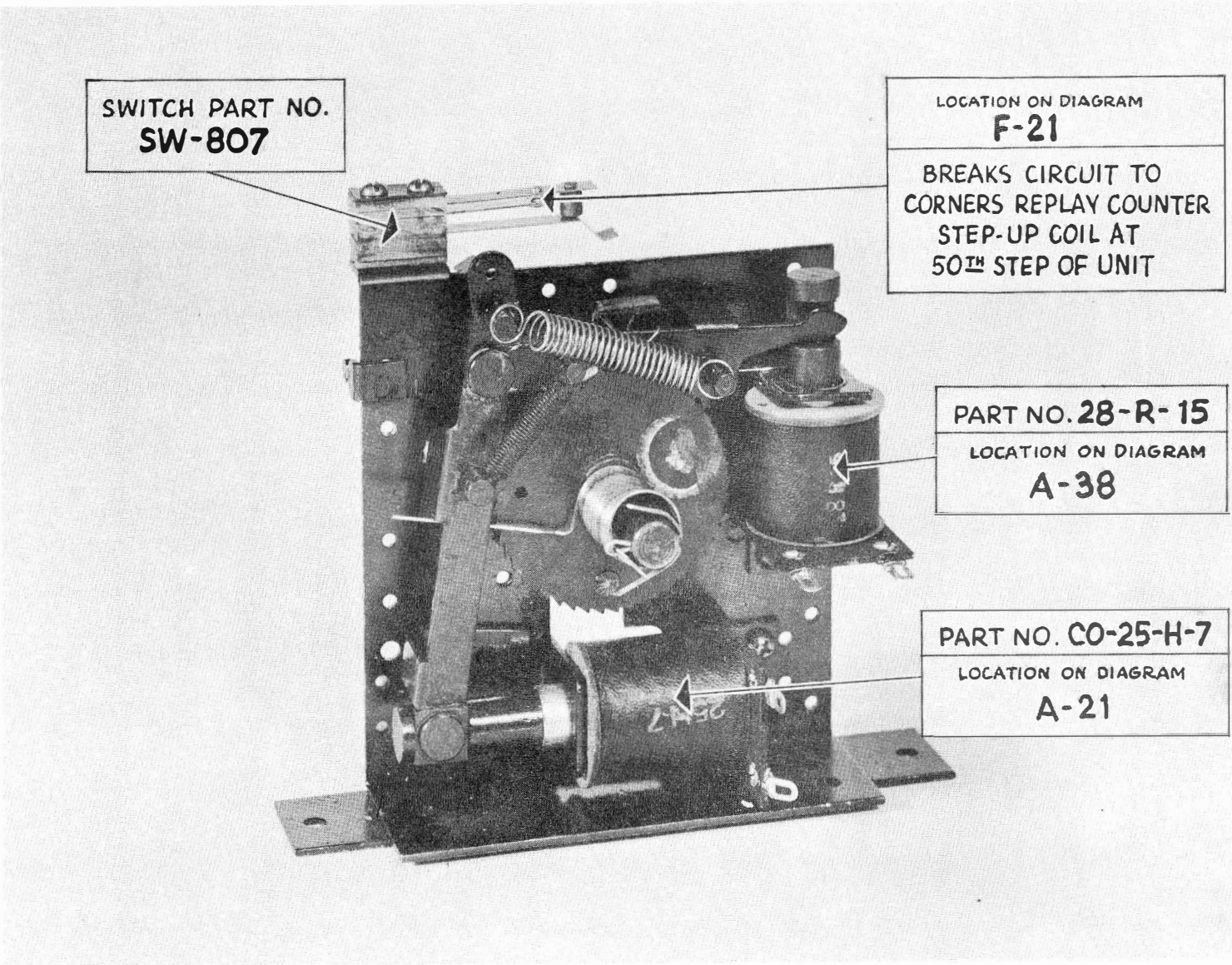

BEACH CLUB

SHUTTER MOTOR

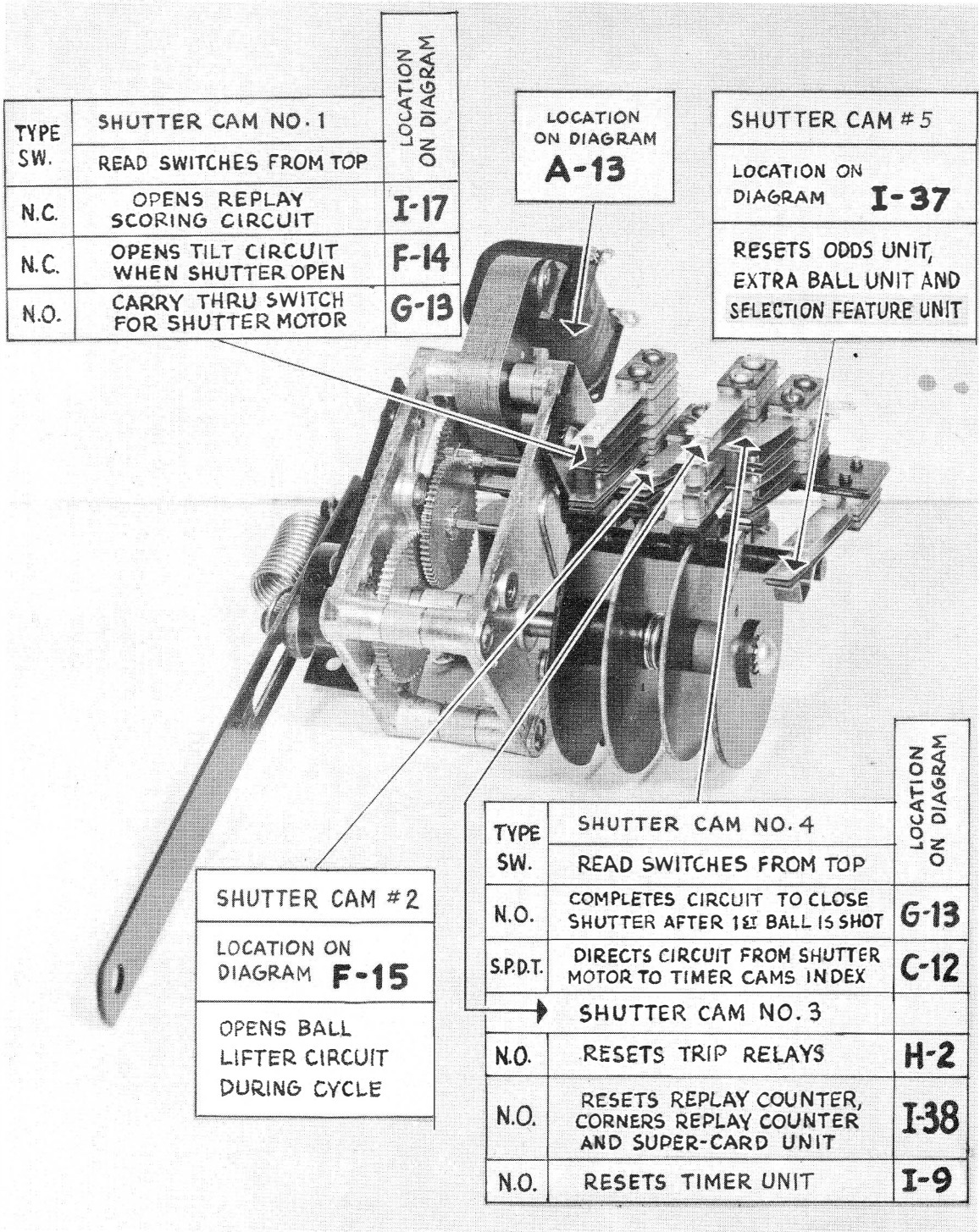

NOTES

NOTES

BEACH CLUB

ROTARY SELECTOR (FRONT CABINET) INSTRUCTIONS

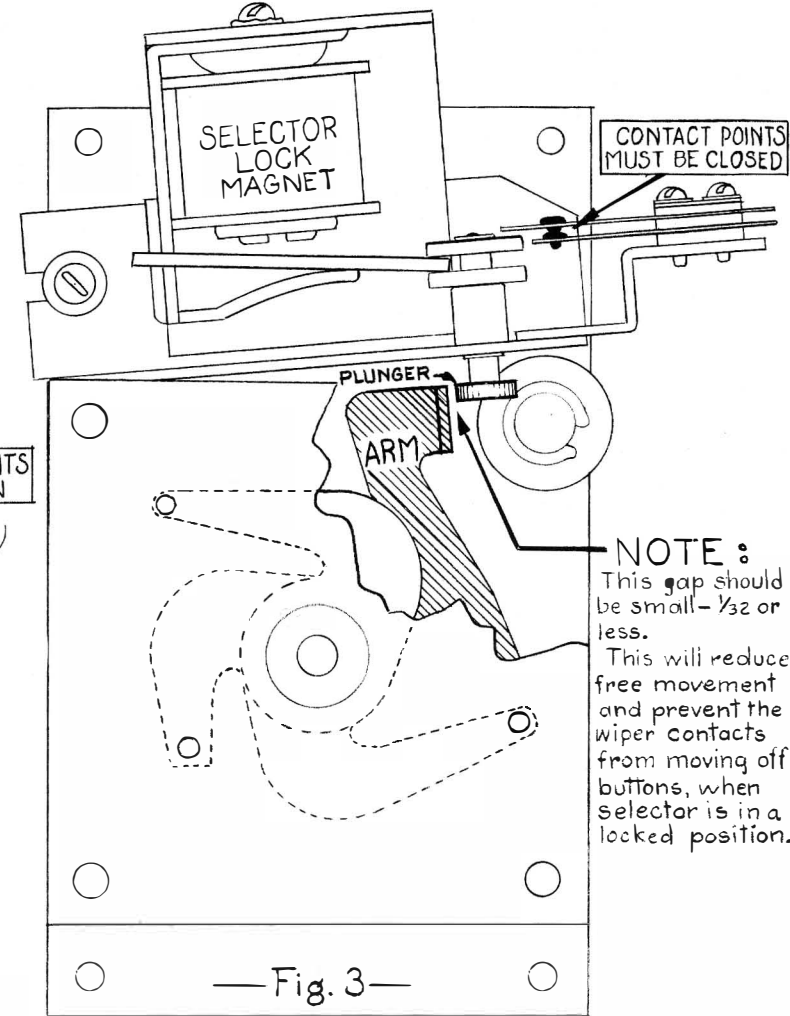
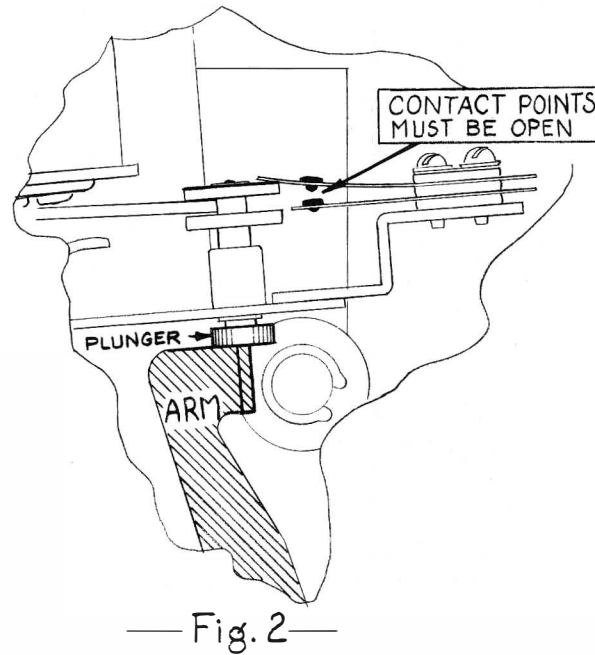
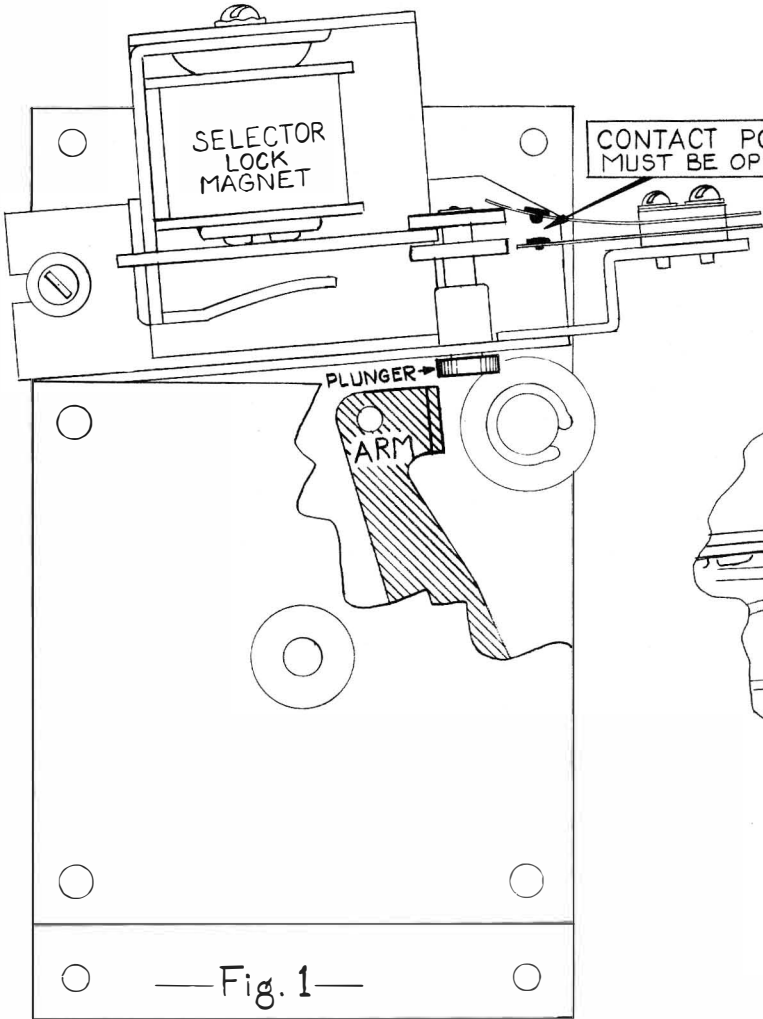

"Fig. 1" shows the selector lock magnet energized. When the magnet is energized, the rotary selector wipers should be free to turn. The switch contact points **MUST BE OPEN** at this time, as shown. This adjustment is very important.

"Fig. 2" shows the selector lock magnet **NOT ENERGIZED**, but shows that the arm can be held in a position to prevent the plunger from returning to a normal locked position. The switch contact points **MUST BE OPEN** at this time, as shown. This adjustment is very important.

"Fig. 3" shows the selector lock magnet **NOT ENERGIZED**. The plunger is now in a position to hold the arm and prevent the rotary wipers from turning. The switch contact points **MUST BE CLOSED** at this time, as shown. This adjustment is very important.

ROTARY SELECTOR

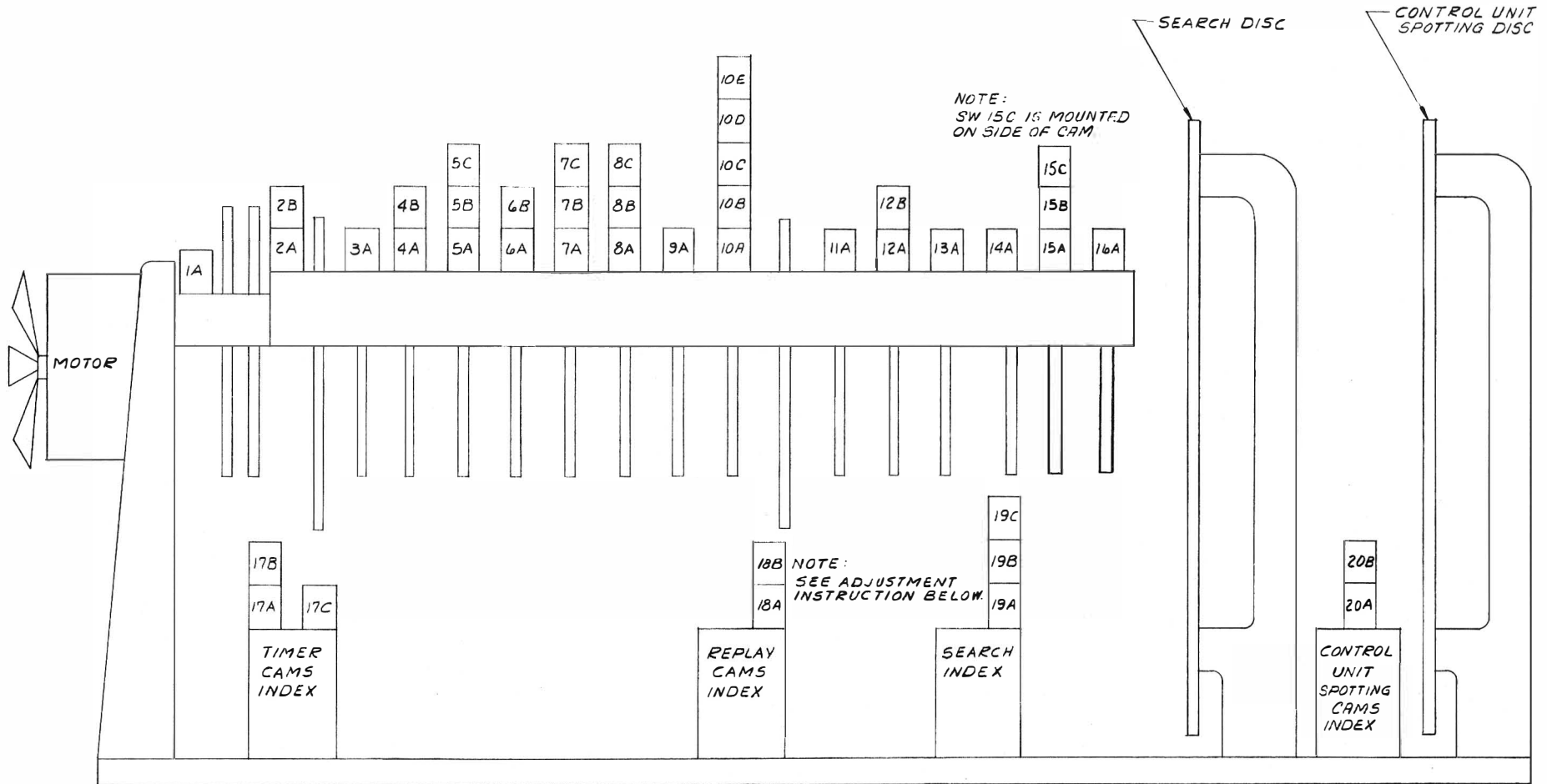

NOTE:
 IT IS IMPORTANT TO ADJUST REPLAY CAMS INDEX SWITCH NO. 18A AND NO. 18B SO THAT THEY MAKE ONLY WHEN THE REPLAY CAMS INDEX COIL IS ENERGIZED. WHEN THE REPLAY CAMS INDEX COIL IS DE-ENERGIZED, THESE SWITCHES SHOULD OPEN AND REMAIN OPEN WHILE SWITCH IS RIDING ON OUTER EDGE OF CAM.

CONTROL UNIT PICTORIAL VIEW
 NUMBERS CORRESPOND TO SWITCH CHART

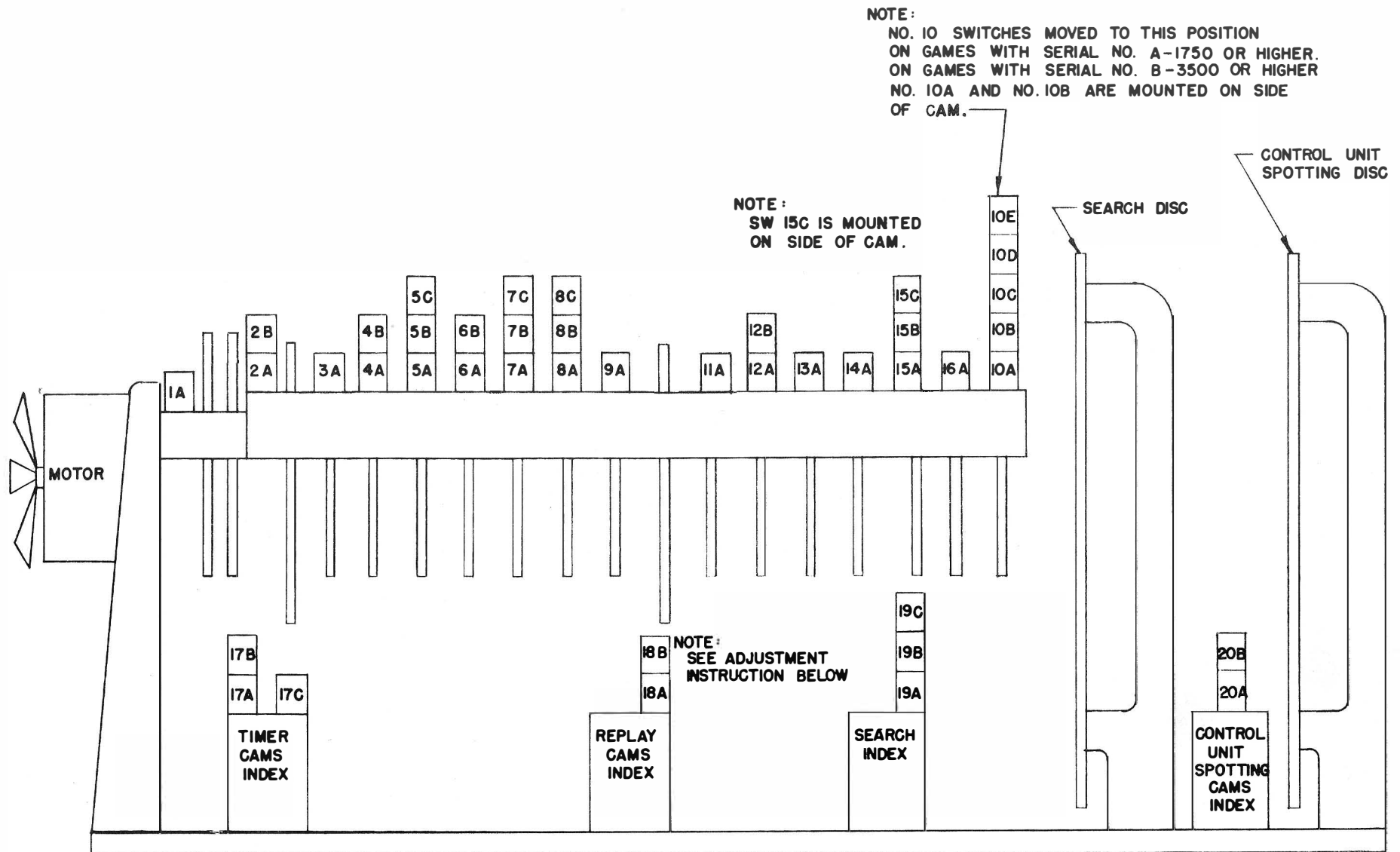

NOTE:
IT IS IMPORTANT TO ADJUST REPLAY CAMS
INDEX SWITCH NO. 18A AND NO. 18B SO THAT
THEY MAKE ONLY WHEN THE REPLAY INDEX
COIL IS ENERGIZED. WHEN THE REPLAY CAMS
INDEX COIL IS DE-ENERGIZED THESE SWITCHES
SHOULD OPEN AND REMAIN OPEN WHILE
SWITCH IS RIDING ON OUTER EDGE OF CAM

CONTROL UNIT PICTORIAL VIEW
NUMBERS CORRESPOND TO SWITCH CHART

BEACH CLUB

CONTROL UNIT CAM SWITCHES

FOR POSITION OF SWITCHES
REFER TO PICTORIAL VIEW ABOVE

CODE	
N.C.	NORMALLY CLOSED
N.O.	NORMALLY OPEN
M. B. B.	MAKE BEFORE BREAK
S.P.D.T. ..	SINGLE POLE DOUBLE THROW

RELAY SWITCH OR CAM SWITCH	LOCATION ON DIAGRAM	WIRE NUMBER	WIRE COLORS	FUNCTION OF SWITCHES
1A N.O.	F-11	65-2 36-10	Brown-White Yellow-Brown	Energizes timer unit step-up coil.
2A N.O.	I-8	30 27-4	Yellow Blue-Orange	Energizes replay register reset coil and reflex play magnet.
2B N.C.	F-13	30 15-2	Yellow Red-White	Drops out extra ball play relay at end of timing cycle.
3A N.C.	I-4	83-3 48-2	Black-Yellow Green-Black	Prevents start relay and extra ball start relay from being pulled in during timing cycle.
4A N.O.	J-12	74 60	Orange-Green Brown	Completes circuit to extra ball flash lites.
4B N.O.	B-35	30 78-4	Yellow Orange-Black	Energizes control unit spotting cams index coil and odds extra step index coil.
5A N.O.	D-36	30 25	Yellow Blue-White	Completes circuit to energize anti-cheat relay, after power to game has been turned off and then on.
5B N.O.	B-22	21-1 63-10	Blue-Red Brown-Yellow	Energizes extra ball unit step-up coil. Steps unit from the minus one position to the zero position.
5C N.O.	G-10	65-2 71-9	Brown-White Orange-Red	Energizes timer reset coil during timing cam cycle.
6A N.C.	F-31	83 74-8	Black-Yellow Orange-Green	Completes circuit to extra ball unit step-up coil for mult
6B N.C.	I-33	30 98-1	Yellow Gray-Black	Completes circuit to super card and selection feature step-up coils for multiple steps.
7A N.O.	C-25	90-5 52-9	Gray White-Blue	Energizes odds unit step-up coil for single steps.
7B N.O.	B-23	25-4 63-10	Blue-White Brown-Yellow	Energizes extra ball unit step-up coil for single steps.
7C N.O.	I-7	30 71-2	Yellow Orange-Red	Pulses coin lock magnet during timing cams cycle.
8A N.O.	B-28	23-10 50-8	Blue-Yellow White	Energizes selection feature step-up coil for single steps.
8B N.O.	D-31	83-8 61	Black-Yellow Brown-Red	Pulse switch for energizing red and yellow star trip relays, also "after 11" center card corners and selection feature trip relays.
8C N.O.	B-33	65-5 36	Brown-White Yellow-Brown	Energizes super card unit step-up coil for single steps.
9A Alt.	C-25	71 25-3	Orange-Red Blue-White	Alternator switch for proportioning odds multiple steps.
10A N.O.	L-9	60-5 23-4	Brown Blue-Yellow	Pulse switch for flashing "select A Lit Number" lite.
10B N.O.	C-7	75-2 53-2	Orange-white White-yellow	Pulse switch for operating replay meter and replay register reset coil when replay reset relay is energized.
10C N.O.	A-21	78 63-10	Orange-Black Brown-Yellow	Pulses extra ball unit step-up coil for multiple steps.
10D N.O.	B-27	85 50-8	Black-White White	Pulses selection feature step-up coil for multiple steps.
10E N.O.	B-32	93-1 36	Gray-Yellow Yellow-Brown	Pulses super card unit step-up coil for multiple steps.
11A N.O.	B-20	36-8 38-8	Yellow-Brown Yellow-Black	2 pulse switch for energizing corners replay counter step-up coil.
12A N.O.	B-19	93-8 54-8	Gray-Yellow White-Green	3 pulse switch for energizing replay counter step-up coil.
12B N.O.	B-21	53-10 38-8	White-Yellow Yellow-Black	3 pulse switch for energizing corners replay counter step-up coil.
13A N.O.	B-19	91-8 54-8	Gray-Red White-Green	4 pulse switch for energizing replay counter step-up coil.
14A N.O.	B-18	90-8 54-8	Gray White-Green	6 pulse switch for energizing replay counter step-up coil.
15A N.O.	B-18	81-8 54-8	Black-Red White-Green	12 pulse switch for energizing replay counter step-up coil.
15B N.O.	B-17	80-10 38-4	Black Yellow-Black	12 pulse switch for energizing replay register step-up coil and reflex replay magnet.
15C N.O.	H-17	27 21-3	Blue-Orange Blue-Red	Completes lock-in circuit for search index coil and replay cams index coil.
16A N.C.	I-18	93 56-7	Gray-Yellow White-Brown	Prevents the start of a second replay scoring until the replay cams are indexed in their normal position.
TIMER CAMS INDEX COIL	A-13	93-2 70	Gray-Yellow Orange	Energized by switches on start relay and extra ball start relay.
17A N.O.	D-12	74-2 81-2	Orange-Green Black-Red	Completes lock-in circuit for extra ball play relay during timing cams cycle.
17B N.C.	G-6	71-2 14-9	Orange-Red Red-Green	Opens circuit to coin lock-out magnet during timer cams cycle.
17C N.O.	G-2	20-P 60-P	Blue (Plastic) Brown (Plastic)	Completes circuit to run control unit motor.
REPLAY CAMS INDEX COIL	A-17	40-4 70	Green Orange	Energized by switch on search index, when 3 or more in line are scored.
18A N.O.	F-17	80-10 27	Black Blue-Orange	Completes lock-in circuit for search index coil and replay cams index coil. NOTE: See pictorial view above for proper adjustment.
18B N.O.	I-18	56-7 93	White-Brown Gray-Yellow	Completes lock-in circuit for search index coil when replay cams index coil is energized. NOTE: See pictorial view above for proper adjustment.
SEARCH INDEX COIL	A-16	80-10 70	Black Orange	Energized when 3 or more in line are scored.
19A N.O.	B-17	40-4 80-10	Green Black	Completes circuit to energize replay cams index coil.
19B N.C.	B-11	27-2 90-9	Blue-Orange Gray	Opens timer step-up coil circuit while replays are being scored.
19C N.C.	I-5	83-3 30	Black-Yellow Yellow	Opens start relay and extra ball start relay circuit while replays are being scored.
SPOTTING CAMS INDEX COIL	A-35	78-4 70	Orange-Black Orange	Energized by control unit cam switch #4B.
20A N.O.	K-5	83-4 36-5	Black-Yellow Yellow-Brown	Completes circuit to flash selection feature lights, super card lights, corners light and "select before shooting" lights.
20B N.O.	K-12	13-4 30-5	Red-Yellow Yellow	Completes circuit to flash odds lights, also red and yellow star roll-over lights.

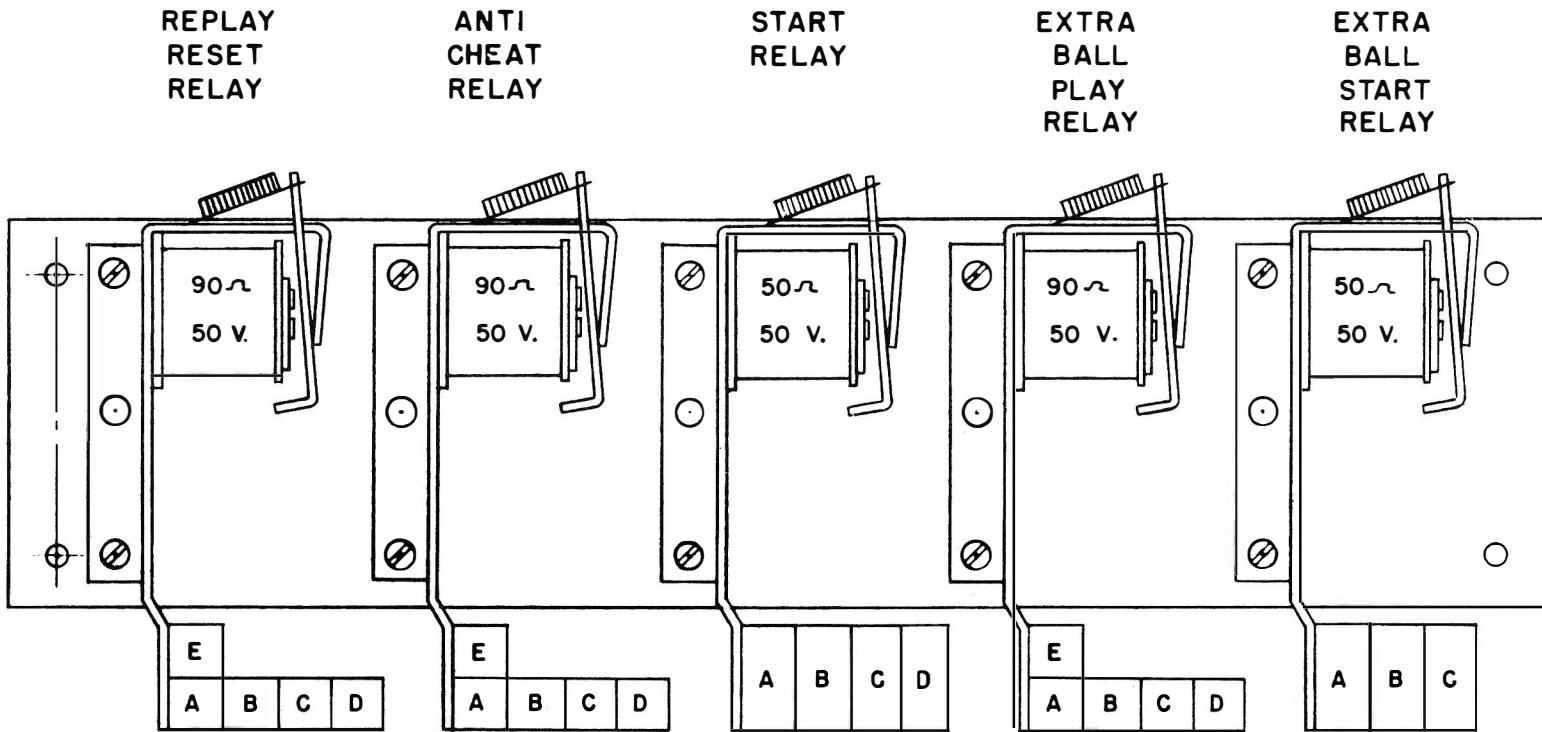

5 RELAY BANK PICTORIAL VIEW
 NUMBERS CORRESPOND TO SWITCH CHART

BEACH CLUB

5 RELAY BANK SWITCHES

FOR POSITION OF SWITCHES
REFER TO PICTORIAL VIEW ABOVE

CODE

N.C. NORMALLY CLOSED
N.O. NORMALLY OPEN
M.B.B. MAKE BEFORE BREAK
S.P.D.T. .. SINGLE POLE DOUBLE THROW

RELAY SWITCH OR CAM SWITCH	LOCATION ON DIAGRAM	WIRE NUMBER	WIRE COLORS	FUNCTION OF SWITCHES
REPLAY RESET RELAY COIL	A-7	75-2 70	Orange-White Orange	Energizes when replays are cancelled by push button or if anti-cheat relay drops out.
A S.P.D.T.	B-8	53-2 13-9 27-4	White-Yellow Red-Yellow Blue-Orange	Directs circuit to replay meter replay cancel.
B N.O.	G-1	60-P 20-P	Brown (Plastic) Blue (Plastic)	Operates control unit motor.
C N.O.	E-7	50-2 75-2	White Orange-White	Lock-in switch for replay reset relay.
D N.C.	F-4	21-6 63-2	Blue-Red Brown-Yellow	Opens start circuit during replay cancel.
E N.C.	E-5	20-3 25-10	Blue Blue-White	Opens extra ball trip and extra ball start relays during cancel.
ANTI-CHEAT RELAY COIL	A-36	25 70	Blue-White Orange	Energized thru cam switch 5A, its switches protect replay circuits.
A N.O.	D-36	25 30	Blue-White Yellow	Lock-in switch for anti-cheat relay.
B N.O.	L-21	56 10	White-Brown Red	Opens 17 volt circuit when relay drops out.
C N.O.	L-17	40 85-7	Green Black-White	Opens 6 volt circuit when relay drops out.
D N.O.	A-12	91-2 93-6	Gray-Red Gray-Yellow	Completes circuit to extra ball play relay.
E N.C.	F-7	75-2 50-2	Orange-White White	Energizes replay reset relay when anti-cheat relay drops out.
START RELAY COIL	A-4	21-6 70	Blue-Red Orange	Energizes every time a coin is played or when a red or yellow button is pressed.
A N.C.	C-12	81-2 91-2	Black-Red Gray-Red	Opens circuit to extra ball play relay.
B N.C.	A-32	36 10-5	Yellow-Brown Red	Opens circuit to super-card unit step-up coil.
C N.O.	H-4	48-2 63-2	Green-Black Brown-Yellow	Lock-in switch for start relay.
D N.O.	E-13	41-3 13-3	Green-Red Red-Yellow	Completes circuit to timer cam index coil.
EXTRA BALL PLAY RELAY COIL	A-12	93-6 70	Gray-Yellow Orange	Energizes when yellow button is pressed.
A S.P.D.T.	G-4	50-2 51-2 63-2	White White-Red Brown-Yellow	Directs circuit to regular start relay or extra ball start relay.
B S.P.D.T.	F-13	74-2 15-2 41-3	Orange-Green Red-White Green-Red	Lock-in switch for extra ball play relay.
C N.O.	J-17	21-4 30	Blue-Red Yellow	Lights extra ball lite in back box.
D N.O.	F-5	51-2 25-10	White-Red Blue-White	Completes circuit to extra ball start and extra ball trip relay.
E N.C.	J-5	83-4 30	Black-Yellow Yellow	Opens super score flash during extra ball play.
EXTRA BALL START RELAY COIL	A-6	20-3 70	Blue Orange	Energizes when yellow button is pressed.
A N.C.	B-21	65-10 75-6	Brown-White Orange-White	Opens circuit to extra ball step-up coil during spin of control unit.
B N.O.	D-12	74-2 93-2	Orange-Green Gray-Yellow	Operates mixer latch and timer cam index coil during extra ball play.
C N.O.	G-6	25-10 48-2	Blue-White Green-Black	Lock-in switch for extra ball start relay.

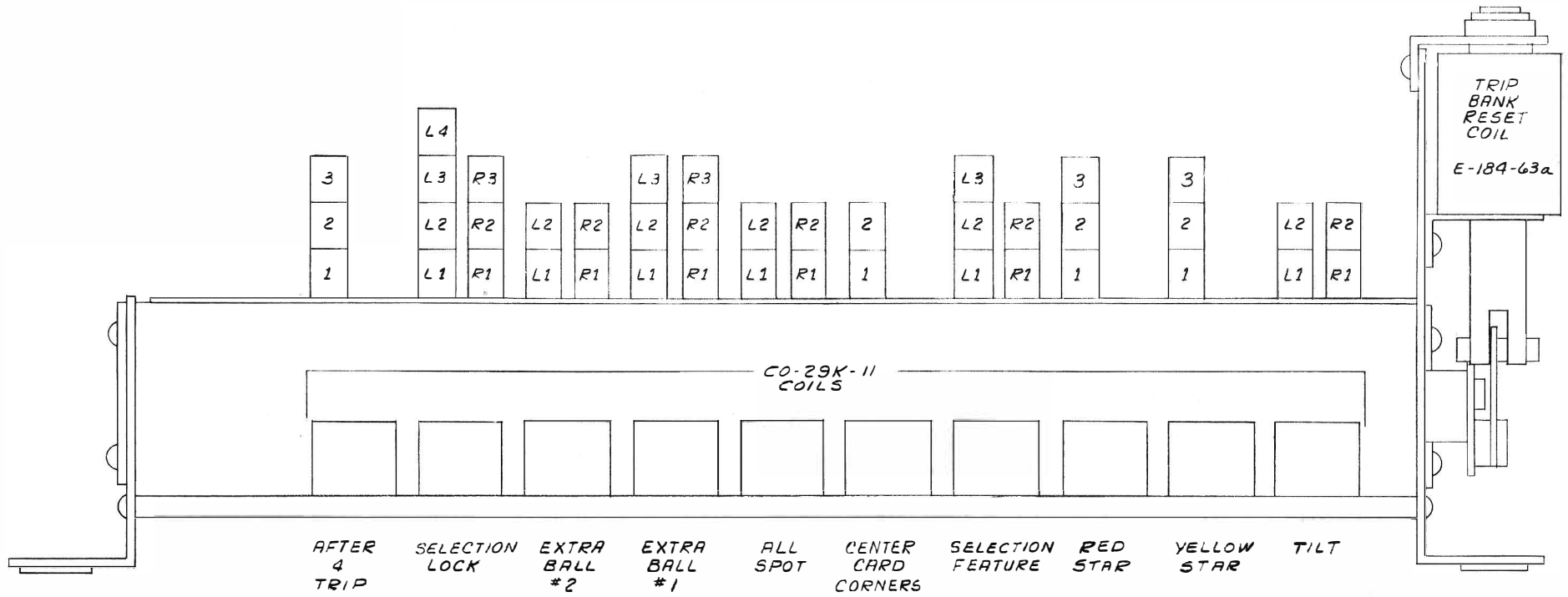

TRIP RELAY BANK PICTORIAL VIEW
NUMBERS CORRESPOND TO SWITCH CHART

BEACH CLUB

TRIP RELAY BANK CHART

FOR POSITION OF SWITCHES
REFER TO PICTORIAL VIEW ABOVE

CODE	
N.C. NORMALLY CLOSED
N.O. NORMALLY OPEN
M.B.B. MAKE BEFORE BREAK
S.P.D.T.	.. SINGLE POLE DOUBLE THROW

RELAY SWITCH OR CAM SWITCH	LOCATION ON DIAGRAM	WIRE NUMBER	WIRE COLORS	FUNCTION OF SWITCHES
AFTER 4 TRIP COIL	A-30	53 70	White-Yellow Orange	Energized by control unit cam switch 8B when selection feature relay is tripped.
1 S.P.D.T.	K-8	75 10-2 13-1	Orange-White Red Red-Yellow	Directs circuit to lite "before shooting 4th ball" or "before shooting 5th ball" lites.
2 S.P.D.T.	I-9	57 30 20-4	White-Orange Yellow Blue	Directs circuit to energize selector lock trip relay coil at the 4th or 5th step of timer unit.
3 N.O.	H-14	36-4 43-2	Yellow-Brown Green-Yellow	Completes circuit to timer step-up coil at 5th step of timer unit.
SELECTION LOCK TRIP COIL	A-9	Jumper 70	Black-Red Orange	Energized by 4th or 5th step of timer unit, directed by "after 4" trip relay switch.
L1 N.O.	I-20	18-4 56-7	Red-Black White-Brown	Completes replay circuit, when this relay is tripped.
L2 N.O.	K-30	20-2 91-10	Blue Gray-Red	Completes circuit to "selected" number in center and super cards.
L-3 N.C.	A-9	Jumper 61-10	Black-Red Brown-Red	Breaks circuit to its own coil, when this relay is tripped.
L-4 N.C.	H-10	21-3 23-5	Blue-Red Blue-Yellow	Opens circuit to rotary selector lock coil.
R-1 N.O.	D-12	13 80-2	Red-Yellow Black	Completes circuit to energize extra ball play relay.
R-2 N.O.	D-11	71-4 27-2	Orange-Red Blue-Orange	Completes circuit to timer step-up coil thru control unit cam switch 1A.
R-3 N.C.	K-8	60-5 15-3	Brown Red-White	Breaks circuit to "select a lit number" lite.
EXTRA BALL #2 TRIP COIL	A-5	81-4 70	Black-Red Orange	Energized by switch on extra ball play relay.
L1 S.P.D.T.	G-25	80-3 41-10 45-6	Black Green-Red Green-White	Directs circuit to odds unit step-up coil or extra ball unit step-up coil.
L2 N.C.	E-31	83-8 74-8	Black-Yellow Orange-Green	Breaks circuit to play-all button advantages.
R1 S.P.D.T.	D-24	71 30 61-2	Orange-Red Yellow Brown-Red	Breaks circuit to odds unit step-up coil and completes circuit to step extra ball unit from minus one to zero position.
R2 N.C.	A-5	20-3 81-4	Blue Black-Red	Breaks circuit to extra ball trip relays #1 and #2.
EXTRA BALL #1 TRIP COIL	A-5	81-4 70	Black-Red Orange	Energized by switch on extra ball play relay.
L1 S.P.D.T.	G-30	75-10 15-6 74-R	Orange-White Red-White Orange-Green	Extra ball proportioning factor thru odds disc.
L2 S.P.D.T.	G-31	14-4 50-10 83	Red-Green White Black-Yellow	Extra ball proportioning factor.
L3 N.O.	C-15	94-1 38-3	Gray-Red Yellow-Black	Completes circuit to ball lifter motor.
R1 S.P.D.T.	J-12	13-4 30 60	Red-Yellow Yellow Brown	Directs circuit to flash odds lites or extra ball lites.
R2 N.O.	G-32	21-5 57-8	Blue-Red White-Orange	Proportioning factor for extra ball steps thru odds disc.
R3 N.O.	H-25	41-10 18-8	Green-Red Red-Black	Proportioning factor for extra ball steps.
ALL SPOT TRIP COIL	A-14	85-9 70	Black-White Orange	Trips when either red or yellow star is lit and ball hits corresponding roll-over switch on panel.
L1 N.O.	J-21	30 27-1	Yellow Blue-Orange	Lights #2 light in all cards.
L2 N.O.	J-22	30 36-1	Yellow Yellow-Brown	Lights #5 light in all cards.
R1 N.O.	J-24	30 43-1	Yellow Green-Yellow	Lights #8 light in all cards.
R2 N.C.	F-25	45-6 78-1	Green-White Orange-Black	Extra ball proportioning factor.
CENTER CARD CORNERS TRIP COIL	A-30	60-2 70	Brown Orange	Energized by control unit cam switch #8B, when circuit is complete thru all other factors.
1 N.O.	J-5	30 98-10	Yellow Gray-Black	Lights center card corners light.
2 N.O.	D-21	21-8 13-8	Blue-Red Red-Yellow	Completes circuit to corners replay counter.

ALL SPOT TRIP COIL	A-14	85-9 70	Black-White Orange	Trips when either red or yellow star is lit and ball hits corresponding roll-over switch on panel.
L1 N.O.	J-21	30 27-1	Yellow Blue-Orange	Lights #2 light in all cards.
L2 N.O.	J-22	30 36-1	Yellow Yellow-Brown	Lights #5 light in all cards.
R1 N.O.	J-24	30 43-1	Yellow Green-Yellow	Lights #8 light in all cards.
R2 N.C.	F-25	45-6 78-1	Green-White Orange-Black	Extra ball proportioning factor.
CENTER CARD CORNERS TRIP COIL	A-30	60-2 70	Brown Orange	Energized by control unit cam switch #8B, when circuit is complete thru all other factors.
1 N.O.	J-5	30 98-10	Yellow Gray-Black	Lights center card corners light.
2 N.O.	D-21	21-8 13-8	Blue-Red Red-Yellow	Completes circuit to corners replay counter.
SELECTION FEATURE TRIP COIL	A-28	38-6 70	Yellow-Black Orange	Energized by control unit cam switch #8B, when circuit is complete thru all other factors.
L1 N.O.	J-7	30 14-1	Yellow Red-Green	Completes circuit to light selection feature lights.
L2 N.O.	D-27	56-10 85	White-Brown Black-White	Completes circuit to selection feature step-up coil.
L3 N.O.	A-29	53 83-10	White-Yellow Black-Yellow	Completes circuit to energize "after 4" trip relay.
R1 N.O.	J-30	30 91-10	Yellow Gray-Red	Completes circuit to "selected" number in center and super cards.
R2 N.C.	G-26	41-10 93-4	Green-Red Gray-Yellow	Proportioning factor for odds steps and extra ball steps.
RED STAR TRIP COIL	A-30	74-10 70	Orange-Green Orange	Energized by control unit cam switch #8B, when circuit is complete thru all other factors.
1 N.O.	J-11	30 53-6	Yellow White-Yellow	Lights red star roll-over light.
2 N.O.	C-14	75-9 85-9	Orange-White Black-White	Completes circuit to energize "all spot" relay when red star roll-over switch is hit.
3 N.C.	B-31	50-4 13-6	White Red-Yellow	Proportioning factor for yellow star trip relay.
YELLOW STAR TRIP COIL	A-31	13-6 70	Red-Yellow Orange	Energized by control unit cam switch #8B, when circuit is complete thru all other factors.
1 N.O.	K-11	30 52-6	Yellow White-Blue	Lights yellow star roll-over light.
2 N.O.	C-14	78-9 85-9	Orange-Black Black-White	Completes circuit to energize "all spot" relay when yellow star roll-over switch is hit.
3 N.C.	B-30	98-5 74-10	Gray-Black Orange-Green	Proportioning circuit for red star trip relay.
TILT TRIP COIL	A-15	23-3 70	Blue-Yellow Orange	Energized by plumb bob tilt in cabinet also by replay reset button switch in cabinet.
L1 N.C.	I-14	30 21-3	Yellow Blue-Red	Breaks 50 volts to ball counting, extra ball and replay circuit.
L2 N.C.	G-1	10-P 60-P	Red (Plastic) Brown (Plastic)	Breaks circuit to control unit motor.
R1 S.P.D.T.	L-18	38 81 41-9	Yellow-Black Black-Red Green-Red	Breaks 6 volt light circuit and lights tilt lite, when relay is tripped.
R-2 N.C.	L-20	20 45-7	Blue Green-White	Breaks 17 volt circuit.

NOTES

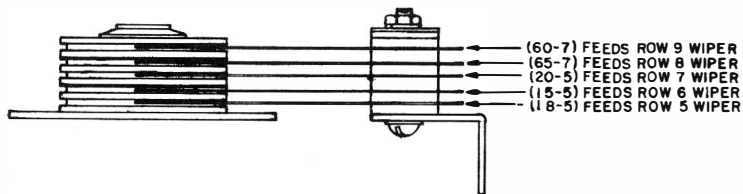
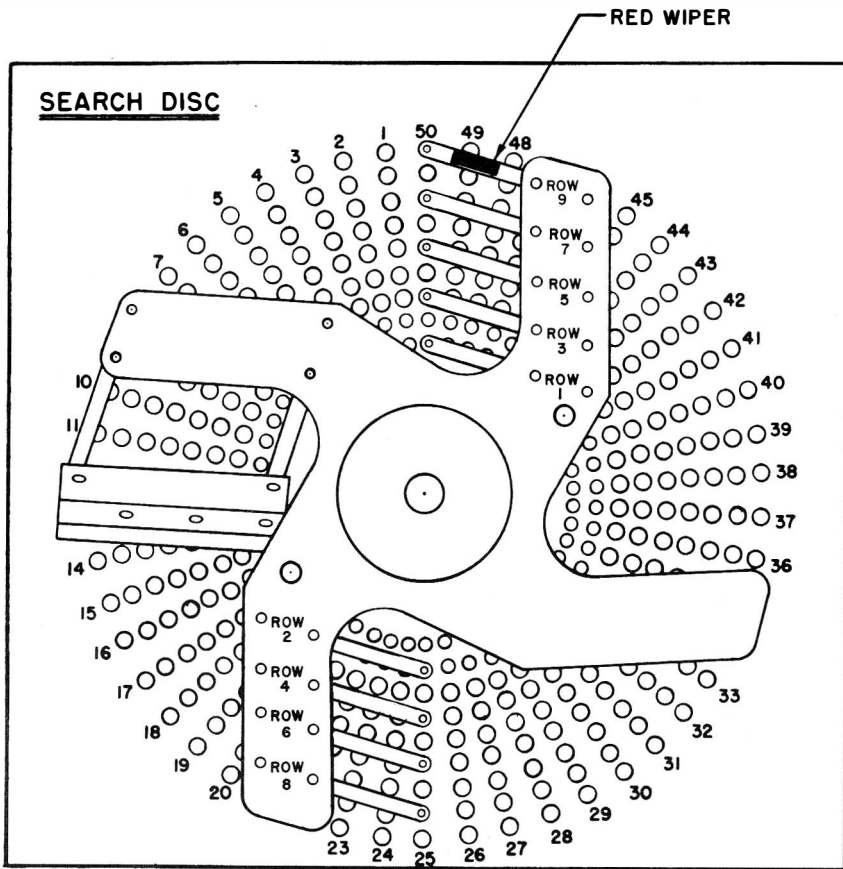

SEARCH POSITIONS					
RED WIPER POSITION	ROW 7 SEARCH RELAY#1	ROW 8 SEARCH RELAY#2	ROW 9 SEARCH RELAY#3	ROW 6 SEARCH RELAY#4	ROW 5 SEARCH RELAY#5
CENTER CARD					
HORIZONTAL					
1	9	4	15	24	6
2	10	19	14	20	8
3	2	18	16	12	25
4	1	22	13	21	17
5	11	7	5	23	3
6	9	10	2	1	11
VERTICAL					
7	4	19	18	22	7
8	15	14	16	13	5
9	24	20	12	21	23
10	6	8	25	17	3
DIAGONAL					
11	6	20	16	22	11
12	9	19	16	21	3
13					
CORNERS					
14	9	6	3	11	
15					
16					
SUPER CARD #2					
HORIZONTAL					
17	15	7	11		
18	1	10	13		
19	17	4	18		
VERTICAL					
20	15	1	17		
21	7	10	4		
DIAGONAL					
22	11	13	18		
23	11	10	17		
24	15	10	18		
25					
CORNERS					
26	15	11	18	17	
27					
28					
SUPER CARD #1					
HORIZONTAL					
29	23	3	18		
30	9	25	11		
VERTICAL					
31	12	24	14		
32	23	9	12		
DIAGONAL					
33	3	25	24		
34	18	11	14		
35	18	25	12		
36	23	25	14		
CORNERS					
37					
38	23	18	14	12	
39					
40					
41					
42					
43					
44					
45					
46					
47					
48					
49					
50					