

Bally[®]

BLUE CHIP

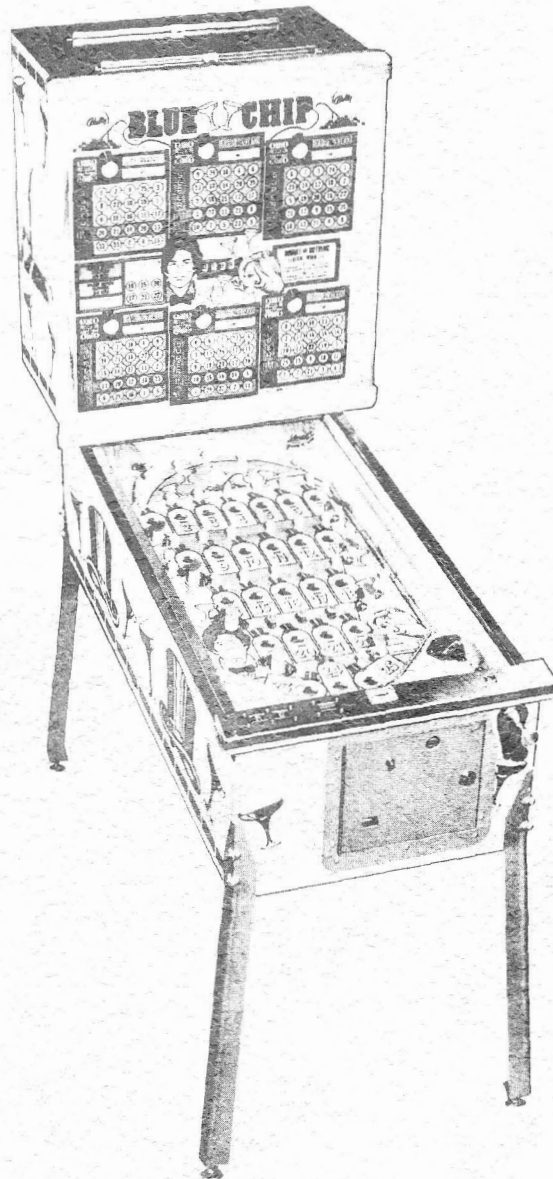

Bally

European Automatic Sales N.V.

Boomssteenweg 87

B-2630 Aartselaar (Belgium)

Phone 031/87 68 00 - Telex 31888 - Cable : Wilmdistri - Antwerpen

INTRODUCTION

Player plays one to 6 coins to select 1 to 6 cards. **Card guaranteed** in numerical order, 1st to 6th, for each coin played—with **progressive scores** as card selection advances.

While cards are selected, the following scoring advantages, related to each card selected, may light on mystery basis: **Corners Panel** (4 corner numbers, lit during ball play, score as 5-in-Line): **Super Line** (3-in-Line scores as 4-in-Line, or 4-in-Line scores as 5-in-Line if lit in lit Super Line), or **Center Number**.

After playing 6 coins, **player may play additional coins** for Select-A-Spot Feature—the privilege of pressing Select-A-Spot Button to select card in which central number is spotted. As the additional coins are played, panels light to indicate whether Select-A-Spot Button must be pressed before 3rd ball is shot or before 4th ball is shot.

WIRE COLOR CODE	
1.... RED	A. FIRST NUMBER IS
2.... BLUE	WIRE BODY COLOR
3.... YELLOW	
4.... GREEN	B. SECOND NUMBER IS
5.... WHITE	TRACER COLOR
6.... BROWN	STRIPE
7.... ORANGE	
8.... BLACK	C. NUMBER AFTER DASH
9.... GRAY	INDICATES RE-USE OF
0.... NO TRACER	SAME COLOR WIRE IN
	A DIFFERENT CIRCUIT.

SWITCH CODE
N.C.... NORMALLY CLOSED
N.O.... NORMALLY OPEN
N.B.B... MAKE BEFORE BREAK
S.P.D.T. SINGLE POLE DOUBLE
THROW OR TRANSFER SW. "T"
NOTE: ALL SWITCHES ON BALLY
DIAGRAMS WORK CLOCKWISE.

MAINTENANCE & SERVICE SUGGESTIONS

To maintain a Game in good working order the game should be kept as clean as possible. Starting with the Coin Chute, for a great deal of Dirt, Metallic Coin Dust, and sticky beverages collect here. An aerosol type de-greaser or contact cleaner can be used, however all parts must be wiped off with a clean cloth to remove any residue & dissolved scum, especially on electrical contacts & printed Circuit Disc.

Keeping the Bottom Cabinet and Back Cabinet free and clear of extra loose parts, screws, nuts, and switch blades, eases trouble shooting; for broken or loose parts often turn up at the bottom of the cabinets making the troubled area easier to identify and correct.

Proper adjustments on Sw. Blades and Wipers should be maintained for proper electrical conduction and machine timing. Overly bent Sw. Blades will break off at the base. Wiper blades under too much pressure will cut through printed circuit discs. Wiper assemblies especially those assembled with multiple fibre discs are very susceptible electrical arcing when covered with even a thin coat of dirt & oil. Arcing will cause carbon traces to build up which will burn a hole through the fibre plates. Arcing shorts are hard to trace and play havoc with a circuit. Arcing can be checked for by giving discs and wipers a physical check.

Also check fibre cams for worn lobes or worn locking notches. In conclusion a clean machine is easier to maintain and keep in service.

CODE	
N.C.-----	NORMALLY CLOSED
N.O.-----	NORMALLY OPEN
M.B.B.-----	MAKE BEFORE BREAK
S.P.D.T.-----	SINGLE POLE DOUBLE THROW

[NOTE: SEE PAGE 44, FOR YOUR CONVENIENCE EXTRA REPLACEMENT SCORE CARDS]

BACK CABINET UNIT LAYOUT

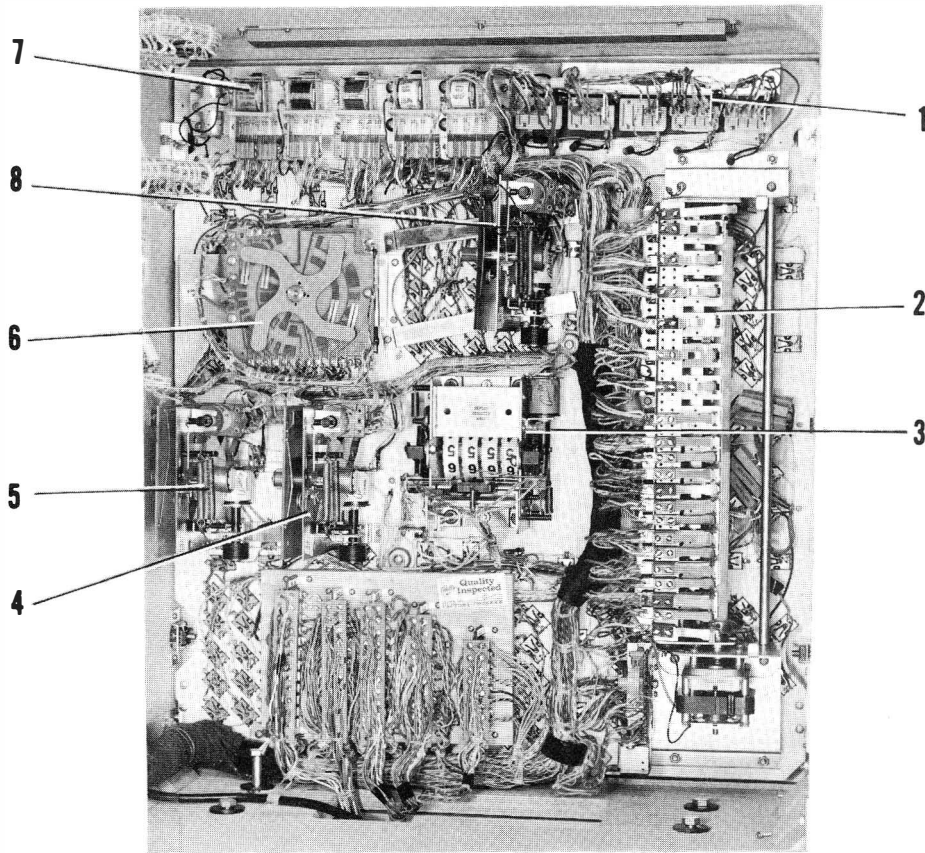

BACK CABINET INSERT

Index No.	Part No.	Description	Page No.
1	E-300-597	Search Relay Bank . . .	27
2	AS-2409-38	13 Trip Bank	15 17
3	AS-473-54	Replay Register Unit . .	40
4	AS-1022-132	#5 Replay Counter . . .	37
5	AS-1022-131	#4 Replay Counter . . .	36
6	AS-2610-29	Random Motor Unit . .	30
7	E-300-826	5 Relay Bank	25 26
8	AS-1022-133	#6 Replay Counter . . .	38

[NOTE: MOLEX PLUG INFORMATION SEE PAGE 44]

ALWAYS GIVE MOEEL AND PART NO. WHEN OROERING SERVICE PARTS

BACK DOOR UNIT LAYOUT

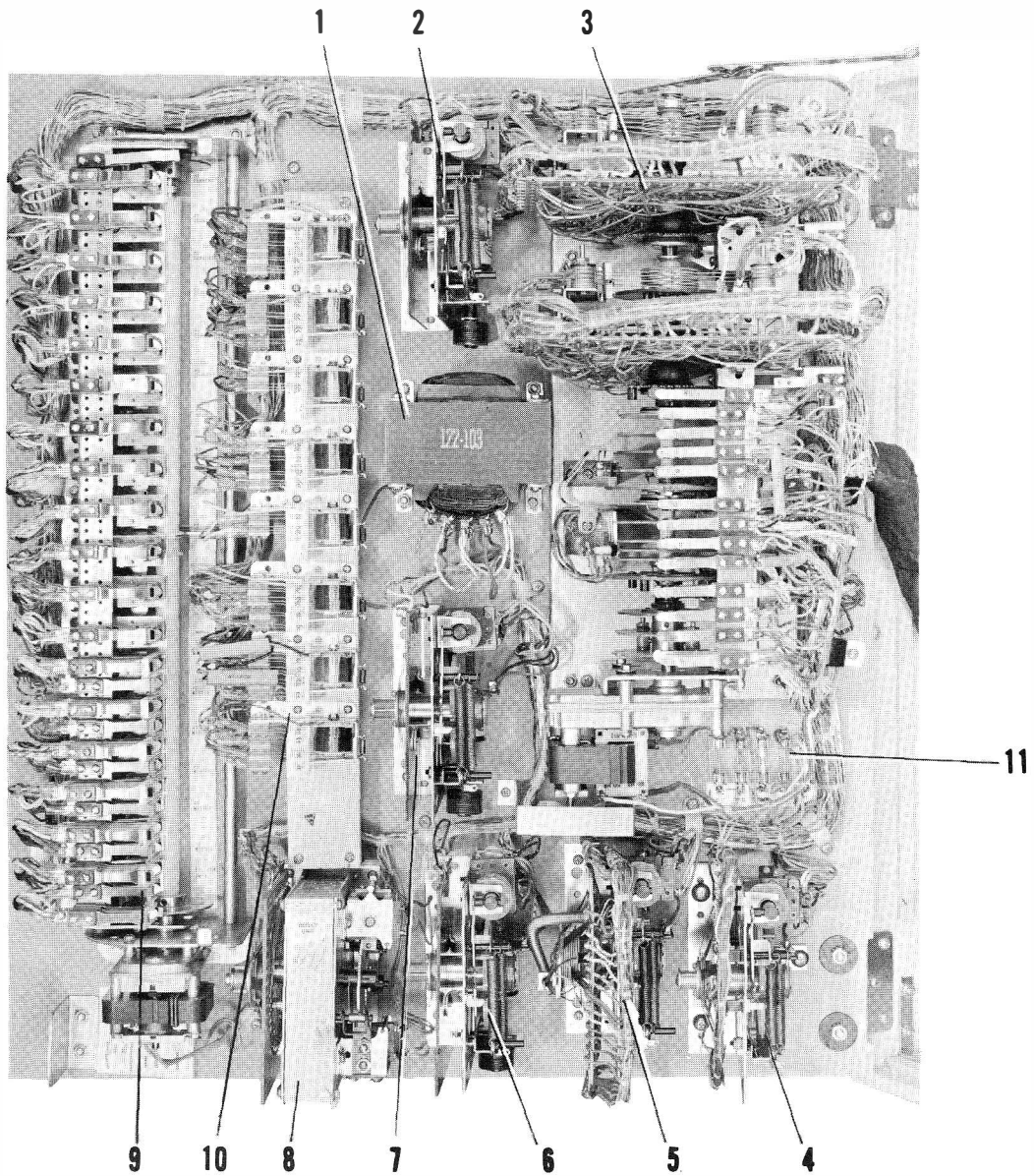

Index No.	Part No.	Description	Page No.
1	E-122-103	Transformer	
2	AS-1022-130	#3 Replay Counter	35
3	AS-798-122	Control Unit	7 13
4	AS-1110-55	Timer Unit	32
5	AS-1022-154	Selection Unit	29
6	AS-1022-128	#1 Replay Counter	33
7	AS-1022-129	#2 Replay Counter	34
8	AS-873-54	Reflex Unit	31
9	AS-2409-35	18 Trip Bank	18 22
10	E-300-828	9 Relay Bank	23 24
11	E-148-5	Fuse Block	
	E-133-10	Fuse	

[NOTE: MOLEX PLUG INFORMATION SEE PAGE 44]

ALWAYS GIVE MODEL AND PART NO. WHEN ORDERING SERVICE PARTS

LOWER FRONT CAB. UNITS

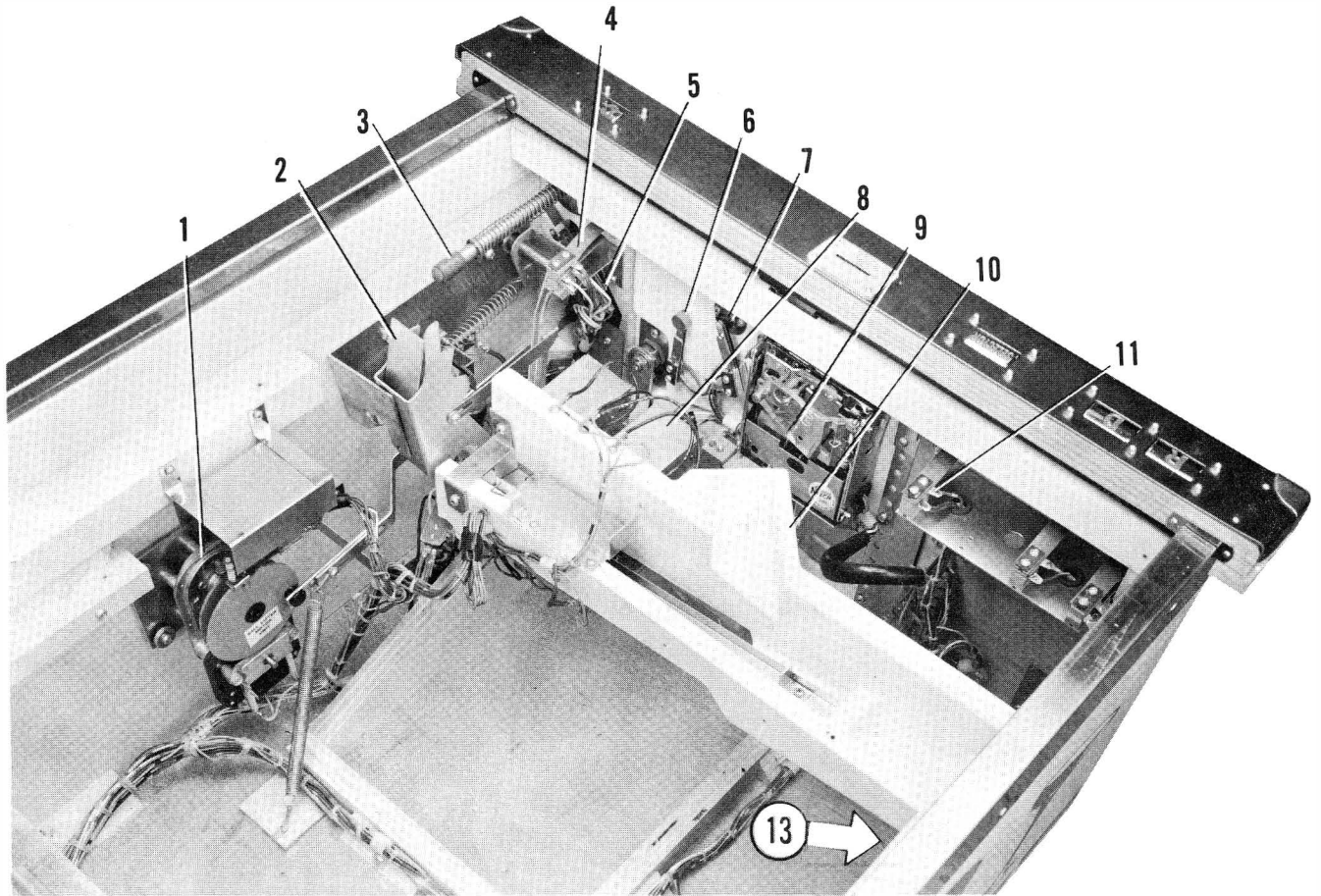

Index No.	Part No.	Description	Page No.
1	AS-1139-34	Ball Lifter Motor Assy.	40
	AS-982-1098	Sw. & Brkt. Assy. . .	
	SP-100-35	Extension Spring . . .	
2	AS-186-11	Ball Lifter Assy. . . .	
3	AS-187-17	Ball Shooter Assy. . . .	
4	AS-982-933	"C" Button Sw. & Brkt. Assembly	41
5	ASW-A2-9	Manual Lift Button Sw.	41
	ASW-A1-26	Manual Lift Button Sw.	
6	ASW-A1-27	Tilt Switch	
7	ASW-A1-37	Replay Sw. (Red Button)	40
8	E-130-10	Counters	
9	AS-277-144	Coin Sw. & Reject Mount	40
	M-1400	Slug Rejector - Specify Coin Denomination .	
10	AS-1145-57	Ball Trough & Sw. Assy.	41
	M-168-15	Ball Set (5)	
11	AS-982-1103	"Selector", "R", and "D" Button Sws. & Brkt. Assy.	41
12	A-2790-59	Cash Box Assy. (NOT SHOWN)	
13	AS-982-673	Replay Key Sw. Assy. (top)	
	AS-982-671	Replay Key Switch Assembly (bottom)	41

[FURTHER PARTS LISTING LAST PAGE]

ALWAYS GIVE MODEL AND PART NO. WHEN ORDERING SERVICE PARTS

PLAYFIELD PANEL

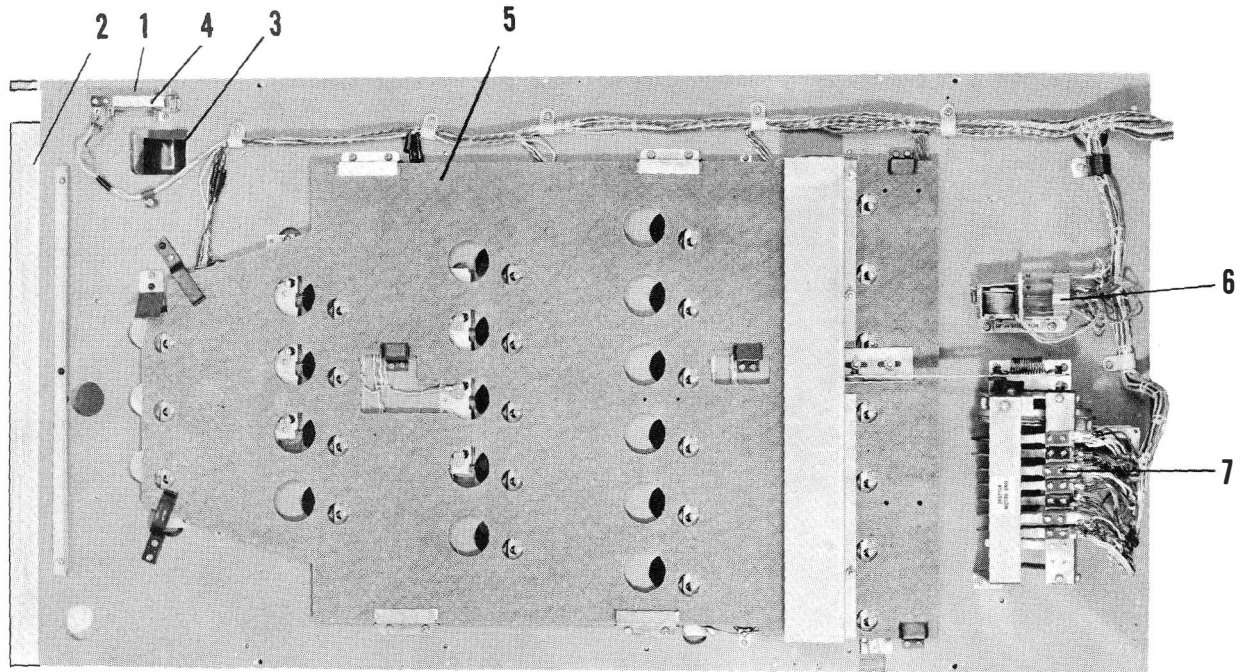

PLAYFIELD PANEL

Index No.	Part No.	Description	Page No.
1	CA-638-92	Panel	
	CA-1104	Panel Top Arch	
	CA-1103	Arch/Ball Guide Strip	
2	CA-1100-4	Arch Bottom	
3	C-153	Red Plastic Ball	
		Lift Cover	
4	ASW-A1-30	Ball Runway Switch	41
5	AS-1433-14	Shutter Assy.	39 40
6	AS-2662-366	Lift Start Relay	40
7	AS-232-93	Shutter Motor Assy.	42

[NOTE: MOLEX PLUG INFORMATION SEE PAGE 44]

ALWAYS GIVE MODEL AND PART NO. WHEN ORDERING SERVICE PARTS

CONTROL UNIT WINNER SEARCH POSITIONS CHART

CARD NO.'S 1, 2, 3

Wiper at Disc Location No. :	Wiper #5 Search Relay No. 1	Wiper #6 Search Relay No. 2	Wiper #7 Search Relay No. 3	Wiper #4 Search Relay No. 4	Wiper #3 Search Relay No. 5		
1.							
2.							
3.							
4.							
5.	Bingo Card No.'s Winners Read Across						
6.							
7.							
8.	8	6	--	10	1	Card No. 3 Corners Winners	
9.	1	18	20	17	10	Card No. 3 Winners	
10.	6	14	20	15	8		
11.	1	2	22	25	8		
12.	24	18	16	15	4		
13.	3	12	20	9	21		
14.	7	14	19	17	13		
15.	6	23	5	11	10		
16.	10	13	21	4	8		
17.	11	17	9	15	25	Super Line	
18.	5	19	20	16	22	Card No. 2 Corners Winners	
19.	23	14	12	18	2		
20.	6	7	3	24	1		
21.	--	--	--	--	--		
22.	3	9	--	10	6		
23.	6	20	15	22	10	Card No. 2 Winners	
24.	9	19	15	21	3		
25.	6	25	17	8	3		
26.	4	20	12	21	23		
27.	16	14	15	11	5		
28.	24	19	18	22	7		
29.	9	13	2	1	10		
30.	10	7	5	23	3		
31.	1	22	11	21	8		Super Line
32.	2	18	15	12	17		Card No. 1 Corners Winners
33.	13	19	14	20	25		
34.	9	24	16	4	6		
35.	--	--	--	--	--		
36.	15	5	--	12	3		
37.	3	19	16	21	12	Card No. 1 Winners	
38.	5	22	16	20	15		
39.	3	7	17	13	15		
40.	25	19	11	20	4		
41.	9	10	16	14	2		
42.	1	22	18	21	23		
43.	5	8	6	24	12		
44.	12	23	2	4	15		
45.	24	21	14	20	13	Super Line	
46.	6	18	16	11	17	Card No. 1 Winners	
47.	8	22	10	19	7		
48.	5	1	9	25	3		
49.	--	--	--	--	--		
50.	--	--	--	--	--		

[Continued]

ALWAYS GIVE MOEEL AND PART NO. WHEN ORDERING SERVICE PARTS

CONTROL UNIT WINNER SEARCH POSITIONS CHART

CARD NO.'S 4, 5, 6

Wiper at Disc Location No.:	Wiper #5 Search Relay No. 1	Wiper #6 Search Relay No. 2	Wiper #7 Search Relay No. 3	Wiper #4 Search Relay No. 4	Wiper #3 Search Relay No. 5	
1.						
2.						
3.						
4.						
5.	Bingo Card No.'s Winners Read Across					
6.						
7.						
8.	6	8	--	1	4	Card No. 6 Corners Winners
9.	4	14	22	15	1	Card No. 6 Winners
10.	8	17	22	18	6	
11.	4	24	5	11	6	
12.	13	14	19	18	3	
13.	10	16	22	9	21	
14.	23	17	12	15	7	
15.	8	2	20	25	1	
16.	1	7	21	3	6	Super Line
17.	25	15	9	18	11	Card No. 5 Corners Winners
18.	20	12	22	19	5	
19.	2	17	16	14	24	
20.	8	23	10	13	4	
21.	--	--	--	--	--	
22.	11	4	--	7	5	Card No. 5 Winners
23.	5	17	21	18	7	
24.	4	15	21	14	11	
25.	5	13	20	8	11	
26.	23	17	12	14	2	
27.	1	3	21	16	22	
28.	6	15	19	18	24	
29.	4	25	9	10	7	Super Line
30.	7	24	22	2	11	Card No. 4 Corner Winners
31.	10	18	16	14	8	
32.	9	19	21	12	20	
33.	25	15	3	17	13	
34.	4	6	1	23	5	
35.	--	--	--	--	--	Card No. 4 Winners
36.	5	3	--	6	9	
37.	9	22	17	20	6	
38.	3	21	17	19	5	
39.	9	8	2	23	5	
40.	4	22	11	19	1	
41.	10	18	17	12	16	
42.	7	21	14	20	25	Super Line
43.	3	24	15	13	6	Card No. 4 Winners
44.	6	25	16	1	5	
45.	13	20	12	19	23	
46.	15	14	17	11	2	
47.	24	21	18	22	8	
48.	3	7	10	4	9	Super Line
49.	--	--	--	--	--	
50.	--	--	--	--	--	

ALWAYS GIVE MODEL AND PART NO. WHEN ORDERING SERVICE PARTS

1 - 2 - 3 CONTROL UNIT SEARCH DISC

VIEWED FROM WIRING SIDE

Search Wiper	Relay Wire No.	Wiper Feeds Relay
1	A 48-3	-
2	Z 95	-
3	40	5
4	38	4
5	20-1	1
6	31	2
7	36	3

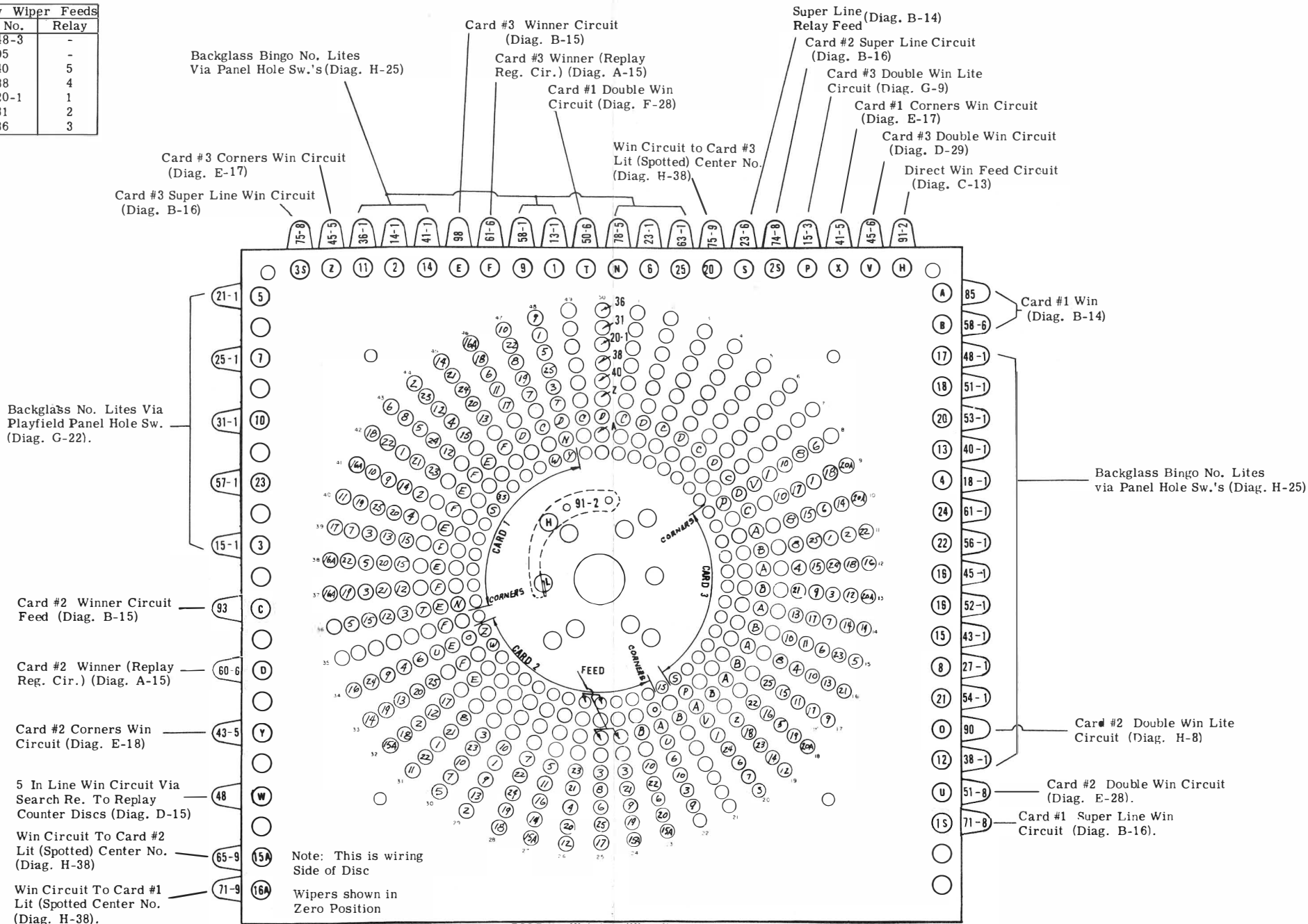

PART NO. W-850-39 (Wired)

4 - 5 - 6 CONTROL UNIT SEARCH DISC

VIEWED FROM WIRING SIDE

Wiper	Wire No.	Relay
1	A 48-3	-
2	Z 95	-
3	40	5
4	38	4
5	20-1	1
6	31	2
7	36	3

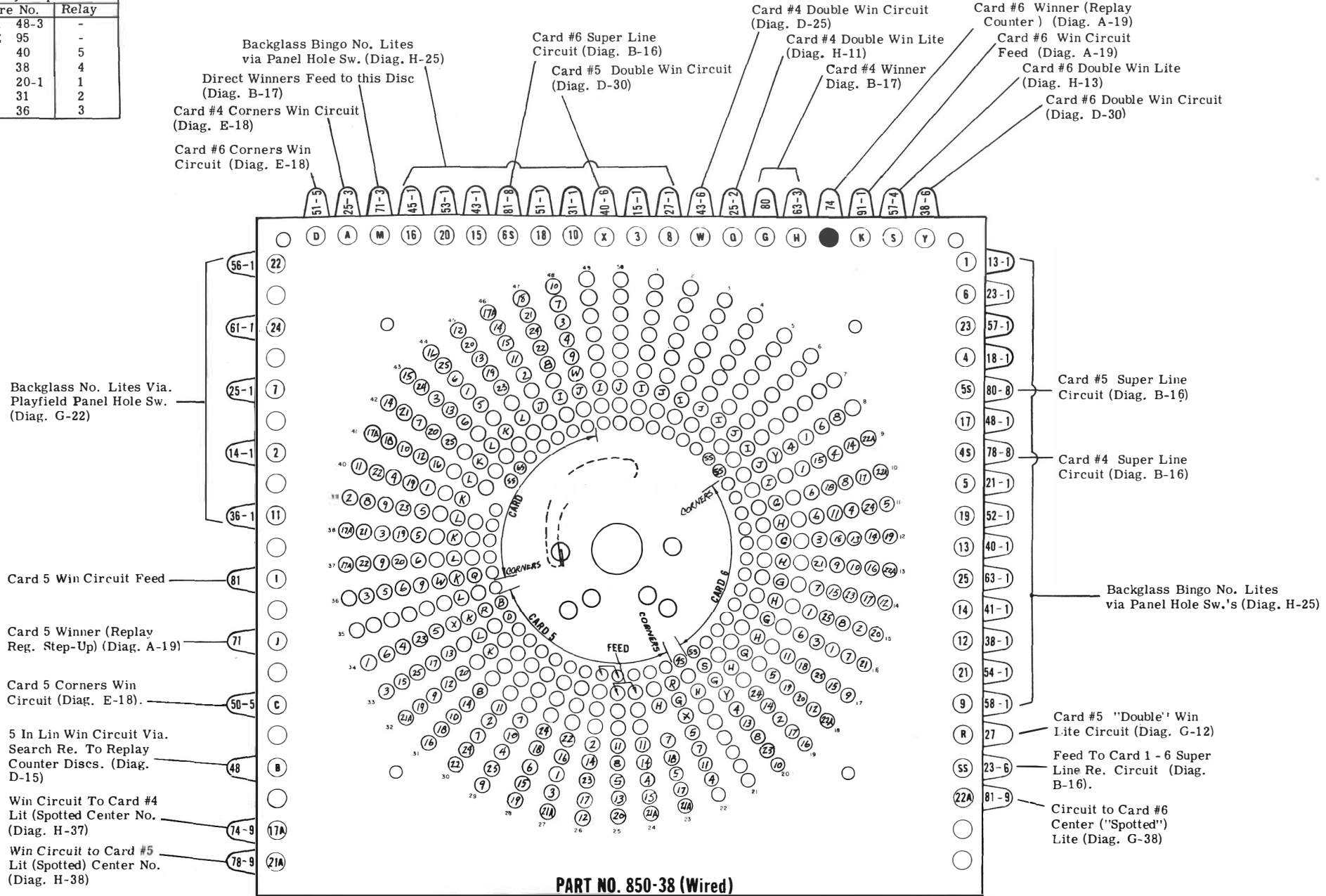

PART NO. 850-38 (Wired)

CONTROL UNIT ASSEMBLY

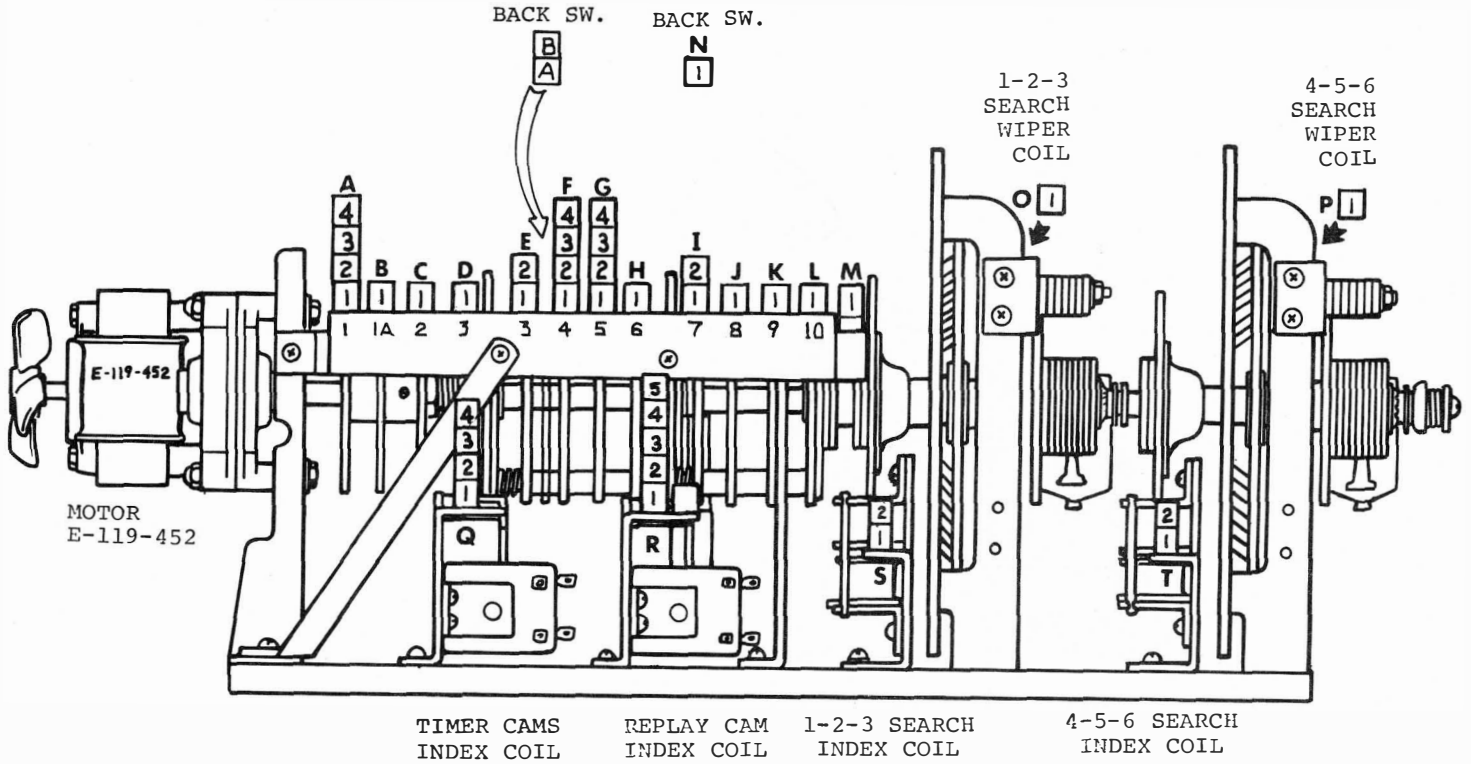

WIRE COLOR CODE	
1... RED	A. FIRST NUMBER IS WIRE BODY COLOR
2... BLUE	B. SECOND NUMBER IS TRACER COLOR STRIPE
3... YELLOW	C. NUMBER AFTER DASH INDICATES RE-USE OF SAME COLOR WIRE IN A DIFFERENT CIRCUIT
4... GREEN	
5... WHITE	
6... BROWN	
7... ORANGE	
8... BLACK	
9... GRAY	
0... NO TRACER	

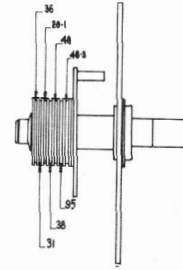

- ORANGE 31
- BROWN 20-1
- WHITE 38
- GREEN 40
- YELLOW 95
- BLUE 48-3
- RED

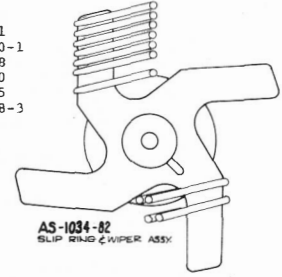

The correct adjustment & synchronization of the Switches controlled by Cam No. 's 8 & 7 is vitally important to the Replay Counter Circuit. Out of adjustment Back Switches CAM 7 BK.SW. can cause the four Replay Counters to become overloaded & burn out (affects the Printed Circuit Disc). Figure 3 shows these Cam Switches in a proper "Made" position. The Back Switches are adjustable. Note that the 7 - switch closes first & opens last.

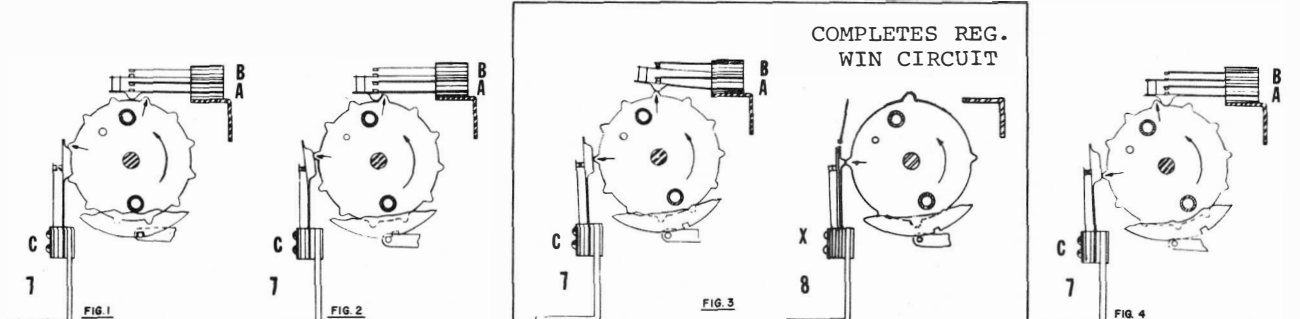

Replay Cam 7 shown in a normal indexed position. Switches A, B, C are open.

Cam 7 starting to rotate. Switches out of indexed pos. Switches A & B are open, Switch C is closed.

Note: A, B, Switches are now made, Switches C & X - are made. All Sw.'s are centered on lobe & perfectly synchronized.

Cam # 7 Switches A & B are now open again, however Switch C is still closed. After this cycle Cam & Switches return to the Fig. 1 position (open).

This entire sequence is repeated throughout the scoring cycle.

CONTROL UNIT FUNCTION CHART

Switch/Control	Part No.	Location on Diagram	Wire No.	Wire Color	Function
MOTOR	E-119-359	E-2	50-16 20-16	White Blue	Operates Unit thru Replay Reset Re-set Relay, Timer Index Cam Sw. & Search Wiper Relay.
A. N.O. Cam #	ASW-C1-3	C-5	75-4 74-1	Orange-White Orange-Green	Resets the Replay Register Reset Coil.
A2 N.C. Cam #1	ASW-C2-4	G-5	20 30	Blue Yellow	Flashes double box and select now lites
A3 T. Cam #1	ASW-C3-2	H-3	61-2 31-7 58-9	Brown-Red Yellow-Red White-Black	Completes a cir. to select B-4, B-3 lites, & top & bottom spots lites
A4 S.P.D.T. Cam #1	ASW-C3-3	G-17	27-8 25-8 23-8	Blue-Orange Blue-White Blue-Yellow	Corner & Super Line Lites Flashes
B1 N.C. Cam 1A	ASW-C1-3	E-38	93-9 48-4	Grey-Yellow Green-Black	Opens circuit to random motor
C1 N.O. Cam #2	ASW-C1-6	D-9	65-2 63-2	Brown-White Brown-Yellow	Steps Timer Unit Step Up Coil
D1 N.C. Cam #3 Pin	ASW-C2-28	F-8	30 93-4	Yellow Gray-Yellow	Opens a circuit to multiplay relay
E1 N.C. Cam #3	ASW-C1-6	F-5	30 80-9	Yellow Black	Opens a circuit to Start Relay
E2 S.P.D.T. Cam #3	ASW-C3-3	C-12	36-2 98-4 91-7	Yellow-Brown Gray-Black Gray-Red	"Not Used" completes a circuit to Total Play & Total Out Meter
Back Sw. 3A N.O.	ASW-C1-47	A-29	71-6J 23-9J	Orange-Red Blue-Yellow	Completes a circuit to #5 corner trip coil
Back Sw. T.	ASW-C3-15	B-32	98-10J 90-10J 93-10J	Grey-Black Grey Grey-Yellow	Completes a circuit to bottom spots trip
F1 N.O. Cam #4	ASW-C1-6	D-22	21-3 27-5	Blue-Red Blue-Orange	Energizes Selection Unit Step Up Coil
F2 N.O. Cam #4	ASW-C1-8	E-27	74-4 85-6	Orange-Green Black-White	Completes a Selection Unit Circuit to Corner & Super Line Trips
F3 N.O. Cam #4	ASW-C1-8	F-5	30 90-5	Yellow Gray	Completes a Circuit to In Reflex Coil
F4 N.O. Cam #4	ASW-C1-8	C-4	15-7 30	Red-White Yellow	Completes a Circuit to Anti-Cheat Relay
G1 N.O. Cam #5	ASW-C1-4	A-7	51-2 98-8	White-Red Gray-Black	Completes a Circuit to Coin Meter
G2 T. Cam #5	ASW-C1-8	D-6	65-1 93-1 78-1	Brown-White Gray-Yellow Orange-Black	Energizes Tilt Trip Relay
G3 B Cam #5	ASW-C3-3	E-13	21-3 31-2	Blue-Red Yellow-Red	Completes a Circuit to Replay Register Step-Up Coil
G4 Cam #5	ASW-A0-11				NOT USED
H1 N.C. Cam #6	ASW-C2-18	E-38	14-9 48-4	Red-Green Green-Black	Opens a Circuit to Random Motor (Feature Wins)
I1 N.O. Cam #7	ASW-C1-3	D-14	41-6 40-2	Green-Red Green	Completes a Circuit to Replay Cam Index Coil
I2 N.O.	ASW-C1-43		Blank 70J		NOT USED
J1 N.O. Cam #8	ASW-C1-6	A-15	70J 13-2	Orange Orange Red-Yellow	Completes a Circuit to 1 thru 6 Replay Counters Regular Win.
K1 N.O. Cam #9	ASW-C1-6	A-15	70 14-8	Orange Red-Green	Completes a Circuit to 1 thru 6 Replay Counters Double Win
L1 N.O. Cam #10	ASW-C1-6	G-14	85-1 23-6	Black-White Blue-Yellow	Completes a Circuit to Super Line Relay thru 1-2-3 & 4-5-6 Search Disc
M1 N.O. Cam #11 Pin	ASW-C1X-17	C-24	21-3 81-7	Blue-Red Black-Red	Completes a Circuit to 1-2-3 Search Wiper Lock Coil.
N1 N.O. Back Switch Cam #7	ASW-C1X-21	D-15	53 78	White-Yellow Orange-Black	Reduce Arcing of Replay Counter

CONTROL UNIT FUNCTION CHART

Switch/Coil	Part No.	Location on Diagram	Wire No.	Wire Color	Function
TIMER CAM INDEX COIL	BF-27-1250	A-8	70 52	Orange White-Blue	Energized thru Start Relay Circuit
1-2-3 Search Wiper Lock Coil	FD-30-1300	A-23	70 27-3	Orange Blue-Orange	Energized thru "C" Button Switch
O1 N. O.	ASW-C1X-4	F-24	21-3 50-1	Blue-Red White	1-2-3 Search Wiper Lock Cam completes circuit to search Wiper Relay
4-5-6 Search Wiper Lock Coil	FD-30-1300	A-24	70 81-7	Orange Black-Red	Energized thru 1-2-3 Search Ratchet Pin Control Unit Cam #11
P1 N. O.	ASW-C2-32	F-24	21-3 50-1	Blue-Red White	4-5-6 Search Wiper Lock Cam completes circuit to Search Wiper Relay
TIMER CAM INDEX COIL	BF-27-1250	A-8	70 52	Orange White-Blue	Energized thru Start Relay Circuit
Q1 N. O.	ASW-A1-11	F-2	10 P 20 P	Red Blue	Completes a circuit to the Control Unit Motor
Q2 N. O.	ASW-A1-54	G-18	25-8 61-8	Blue-White Brown-Red	Completes a Circuit to Corner & Super Line Lites.
Q3 N. O.	ASW-A1-54	G-3	15-5 31-7	Red-White Yellow-Red	Completes Circuit to B-3, B-4 & Press to Select Spot Lites.
Q4 N. C.	ASW-A2-18	B-7	51-2 45-3	White-Red Green-White	Opens Circuit to Coin Lock Out Coil
Lug		A-29	30	Yellow	8200 Ohm, half watt resistor
Lug		A-29	18-4J 18-4	Red-Black Red-Black	8200 Ohm, half watt resistor
Lug		B-32	23-9J 23-9	Blue-Yellow Blue-Yellow	8200 Ohm, half watt resistor
Lug		B-32	90-10J 93-10J 98-10J	Grey Grey-Yellow Grey-Black	8200 Ohm, half watt resistor
REPLAY CAM INDEX COIL	CF-28-1025	A-14	70 40-2	Orange Green	Energized thru Regular Win Relay Sw. & Double Win Relay Sw.
R1 N. O.	ASW-A1-11	E-15	53 21-3	White-Yellow Blue-Red	Hold in Circuit for Replay Cam Index Coil
R2 N. O.	ASW-A1-56	F-14	85-1 23-6	Black-White Blue-Yellow	Completes Circuit to 1-2-3 & 4-5-6 Search Index Disc
R3 N. C.	ASW-A2-27	B-9	63-2 60-2	Brown-Yellow Brown	Open Circuit to Timer Unit Step Up Coil
R4 N. C.	ASW-A2-51	C-26	61 57-7	Brown-Red White-Orange	Opens a Circuit to Double Play Relay Coil
R5 N. O.	ASW-A1-56	C-37	14-9 15-6	Red-Green Red-White	Completes Circuit to Random Motor thru Replay Index Cam Sw.
1-2-3 Search Index Coil	EA-29-950	B-15	70 85-5	Orange Black-White	Energized thru 1-2-3 Search Disc on Winner
S1 N. O.	ASW-A2-43	C-15	78 91-2	Orange-Black Gray-Red	Hold in circuit for 1-2-3 Search Index Relay
S2 N. O.	ASW-A2-49	F-33	21-3 81-5	Blue-Red Black-Red	Completes Circuit to Search Index Relay
4-5-6 Search Index Coil	EA-29-950	A-19	70 98-5	Orange Gray-Black	Energized thru 4-5-6 Search Disc on Winner
T1 N. O.	ASW-A2-43	D-15	78 71-3	Orange-Black Orange-Red	Hold In Circuit for 4-5-6 Search Index Relay
T2 N. O.	ASW-A2-49	F-33	81-5 21-3	Black-Red Blue-Red	Completes Circuit to Search Index Relay.

ALWAYS GIVE MODEL AND PART NO. WHEN ORDERING SERVICE PARTS

TRIP RELAY ASSEMBLY 13

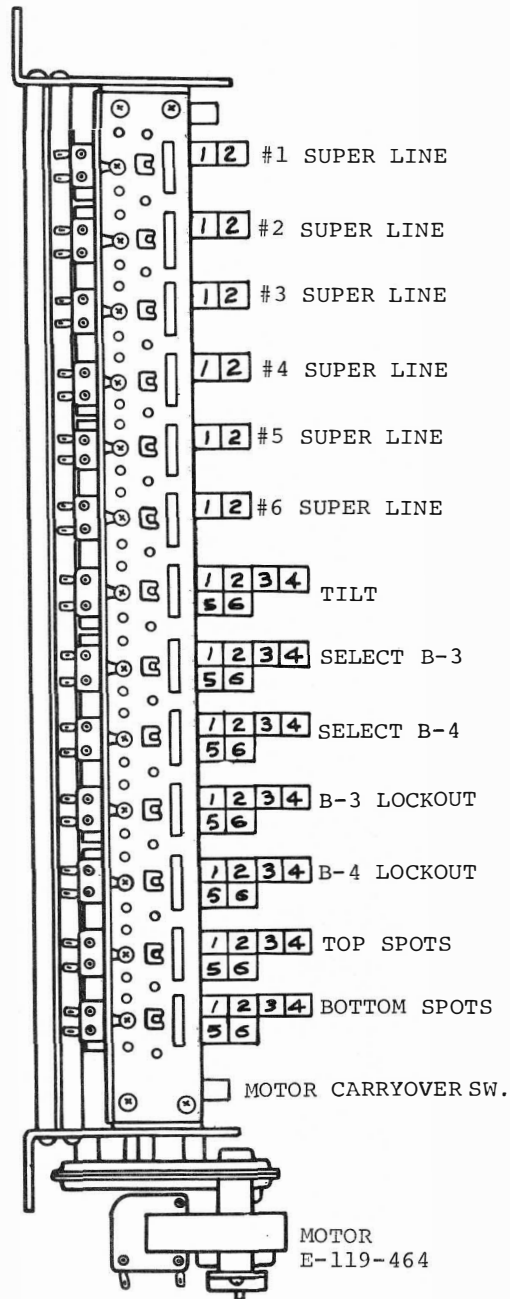

TRIP RELAY ASSEMBLY 13

Switch/Coil	Part No.	Location on Diagram	Wire No.	Wire Color	Function
MOTOR	E-119-362	A-22	70 83-3	Orange Black-Yellow	Energize thru shutter cam #3-17.
#1 Super Line Trip Relay	D-27-425	A-29	70 13-5	Orange Red-Yellow	Energized thru selection & random unit discs
1. S.P.D.T.	ASW-B-3	G-15	23-8 98-9 30	Blue-Yellow Gray-Black Yellow	Completes circuit to card #1 super lite
2. N.O.	ASW-B-1	B-17	71-8 57	Orange-Red White-Orange	Energized super line relay on card #1 Winner
#2 Super Line Trip Relay	D-27-425	A-29	70 14-7	Orange Red-Green	Energized thru selection & random unit discs.
1. S,P.D.T.	ASW-B-3	G-15	27-8 95-6 30	Blue-Orange Gray-White Yellow	Completes circuit to card #2 super lite
2. N.O.	ASW-B-1	G-17	74-8 57	Orange-Green White-Orange	Energized super line relay on card #2 winner.
#3 Super Line Trip Relay	D-27-425	A-30	70 15-2	Orange Red-White	Energized thru selection & random unit discs.
1. S.P.D.T.	ASW-B-3	G-16	23-8 93-6 30	Blue-Yellow Gray-Yellow Yellow	Completes circuit to card #3 super lite
2. N.O.	ASW-B-1	B-18	75-8 57	Orange-White White-Orange	Energized super line relay on card #3 winner.
#4 Super Line Trip Relay	D-27-425	A-30	70 18-7	Orange Red-Black	Energized thru selection & random unit discs.
1. S.P.D.T.	ASW-B-3	G-16	27-8 91-5 30	Blue-Orange Gray-Red Yellow	Completes circuit to card #4 super lite
2. N.O.	ASW-B-1	B-18	78-8 57	Orange-Black White-Orange	Energized super line relay on card #4 winner.
#5 Super Line Trip Relay	D-27-425	A-30	70 20-6	Orange Blue	Energized thru selection & random unit discs.
1. S.P.D.T.	ASW-B-3	G-16	23-8 90-3 30	Blue-Yellow Gray Yellow	Completes circuit to card #5 super lite.
2. N.O.	ASW-B-1	B-18	80-8 57	Black White-Orange	Energized super line relay on card #5 winner.
#6 Super Line Trip Relay	D-27-425	A-30	70 23-3	Orange Blue-Yellow	Energized thru selection & random unit discs.
1. S.P.D.T.	ASW-B-3	G-17	27-8 85-7 30	Blue-Orange Black-White Yellow	Completes circuit to card #6 super lite
2. N.O.	ASW-B-1	B-18	81-8 57	Black-Red White-Orange	Energizes super line relay on card #6 winner
Tilt Trip Coil	D-27-425	A-11	70 65-1	Orange Brown-White	Energized thru all tilt switches and replay key sw.
1. N.C.	ASW-B-2	E-2	81-16 20-16	Black-Red Blue	Open circuit to control unit motor
2. N.C.	ASW-B-2	H-19	14-10 10	Red-Green Red	Open circuit to all 17 volts lites
3. S.P.D.T.	ASW-B-3	H-18	51-7 41-10 13-10	White-Red Green-Red Red-Yellow	Open circuit to all 6 volts lites and completes circuit to tilt lite
4. S.P. D.T.	ASW-B-3	F-9	21-3 30 36-3	Blue-Red Yellow Yellow-Brown	Energizes shutter motor in tilt position

TRIP RELAY ASSEMBLY 13

Switch/Coil	Part No.	Location on Diagram	Wire No.	Wire Color	Function
Select B-3 Trip Relay Coil	D-27-425	A-31	70 83 J	Orange Black-Yellow	Energized thru selection unit & random unit disc.
1. N. C.	ASW-B-2	A-31	83-8 83 J	Black-Yellow Black-Yellow	Open circuit to select B-3 trip relay coil.
2. N. O.	ASW-B-1	A-40	38-5 43-10	Yellow-Black Green-Yellow	Completes circuit to spot selector step up coil.
3. S.P.D.T.	ASW-B-2	G-2	58-9 52-6 30	White-Black White-Blue Yellow	Completes circuit to select B-3 lite.
4. N. O.	ASW-B-1	G-33	30 36-8	Yellow Yellow-Brown	Completes circuit to spot selection disc.
5. N. O.	ASW-B-1	G-1	40-8 41-3	Green Green-Red	Completes circuit to select now lite.
6. N. O.	ASW-B-1	C-32	83-8 54-5	Black-Yellow White-Green	Completes circuit to top spot trip.
Select B-4 Trip Relay Coil	D-27-425	A-31	70 91	Orange Gray-Red	Energized thru selection unit & random unit disc.
1. N. C.	ASW-B-2	A-31	91-8 91 J	Gray-Red Gray-Red	Open circuit to B-4 trip relay coil.
2. S.P.D.T.	ASW-B-3	C-40	10-5 25-5 31-3	Red Blue-White Yellow-Red	Open circuit to spot selector step up coil.
3. S.P.D.T.	ASW-B-3	H-2	53-3 52-6 61-2	White-Yellow White-Blue Brown-Red	Completes circuit to select B-3 & select B-4 lites.
4. S.P.D.T.	ASW-B-3	H-1	45-2 51-3 48-5	Green-White White-Red Green-Black	Completes circuit to select now lite.
5. N. C.	ASW-B-2	E-5	63-4 27-4	Brown-Yellow Blue-Orange	Open circuit to start relay & coin lockout coil.
6. N. C.	ASW-B-2	C-32	54-5 90-10	White-Green Gray	Open circuit tottop spots trip
7. N. O.	ASW-B-1	C-32	91-8 90-10	Gray-Red Gray	Completes circuit to bottom stop trip.
8. N. O.	ASW-B-1	A-31	83-8 85-6	Black-Yellow Black-White	Completes circuit to select B-3 trip.
B-3 Lockout Trip Relay Coil	D-27-425	A-39	70 71 J	Orange Orange-Red	Energized thru timer unit disc.
1. N. C.	ASW-B-2	A-39	71-4 71 J	Orange-Red Orange-Red	Open circuit to B-3 lockout trip coil.
2. N. C.	ASW-B-2	C-40	10-5 38-5	Red Yellow-Black	Open circuit to spot selector step up coil.
3. N.	ASW-B-2	H-1	45-2 40-8	Green-White Green	Open circuit to select now lite
4. N. O.	ASW-B-1	E-10	53-6 48-6	White-Yellow Green-Black	Completes a circuit to timer unit reset coil.
B-4 Lockout Trip Relay Coil	D-27-425	A-40	70 75 J	Orange Orange-White	Energize thru timer unit disc.
1. N. C.	ASW-B-2	A-40	75 75 J	Orange-White Orange-White	Open circuit to B-4 lockout trip coil
2. N. C.	ASW-B-2	C-40	31-3 38-5	Yellow-Red Yellow-Black	Open circuit to spot selector step up coil.
3. N. C.	ASW-B-2	G-2	48-5 40-4	Green-Black Green	Open circuit to select now lite
4. N. O.	ASW-B-1	F-26	21-3 93-7	Blue-Red Gray-Yellow	Completes circuit to 1-2-3 & 4-5-6 search wiper lock coil.
5. N. O.	ASW-B-1	E-9	50-2 65-2	White Brown-White	Completes circuit to timer step up coil.
6. N. O.	ASW-B-1	C-25	52-3 98-1	White-Blue Gray-Black	Completes circuit to timer reset coil.

TRIP RELAY ASSEMBLY 13

Switch/Coil	Part No.	Location on Diagram	Wire No.	Wire Color	Function
Top Spot Trip	D-27-425	A-32	70 93-10J	Orange Grey-Yellow	Energizes top spot trip relay
1. N.C.	ASW-B-1	A-32	93-10 93-10J	Grey-Yellow Grey-Yellow	Opens circuit to spot trip relay
2. T.	ASW-B-1	A-32	93-10 93-10J	Grey-Yellow Grey-Yellow	Opens circuit to spot trip relay
3. N.O.	ASW-B-1	G-34	15-10 71-9	Red-White Orange-Red	Complets circuit to #16 lite Card #1
4. N.O.	ASW-B-2	G-34	18-10 65-9	Red-Black Brown-White	Complets circuit to #15 lite Card #2
5. N.C.	ASW-B-2	F-5	63-4 27-4	Brown-Yellow Blue-Orange	Opens circuit to replay register
6. N.O.	ASW-B-1	G-34	20-10 75-9	Blue Orange-White	Complets circuit to #20 lite Card #3
Bottom Spot Trip	D-27-425	A-32	70 98-10J	Orange Grey-Black	Energizes bottom spot trip relay
1. N.C.	ASW-B-1	A-32	98-10 98-10J	Grey-Black Grey-Black	Opens circuit to bottom trip relay
2. T.	ASW-B-1	I-3	51-9 30 58-9	White-Black Yellow White-Red	51-9 directs circuit to bottom spot lites 58-9 directs circuit to B-3,
3. N.O.	ASW-B-3	H-35	21-10 74-9	Blue-Red Orange-Green	Completes circuit to #17 lite Card #4
4. N.O.	ASW-B-2	H-35	23-10 78-9	Blue-Yellow Orange-Black	Completes circuit to #21 lite Card #5
5. N.C.	ASW-B-1	F-5	63-4 27-4	Brown-Yellow Blue-Orange	Opens circuit to replay register
6. N.C.	ASW-B-2	H-35	25-10 81-9	Blue-White Black-Red	Completes circuit to #22 lite Card #6

ALWAYS GIVE MOOEL AND PART NO. WHEN ORDERING SERVICE PARTS

TRIP RELAY BANK 18

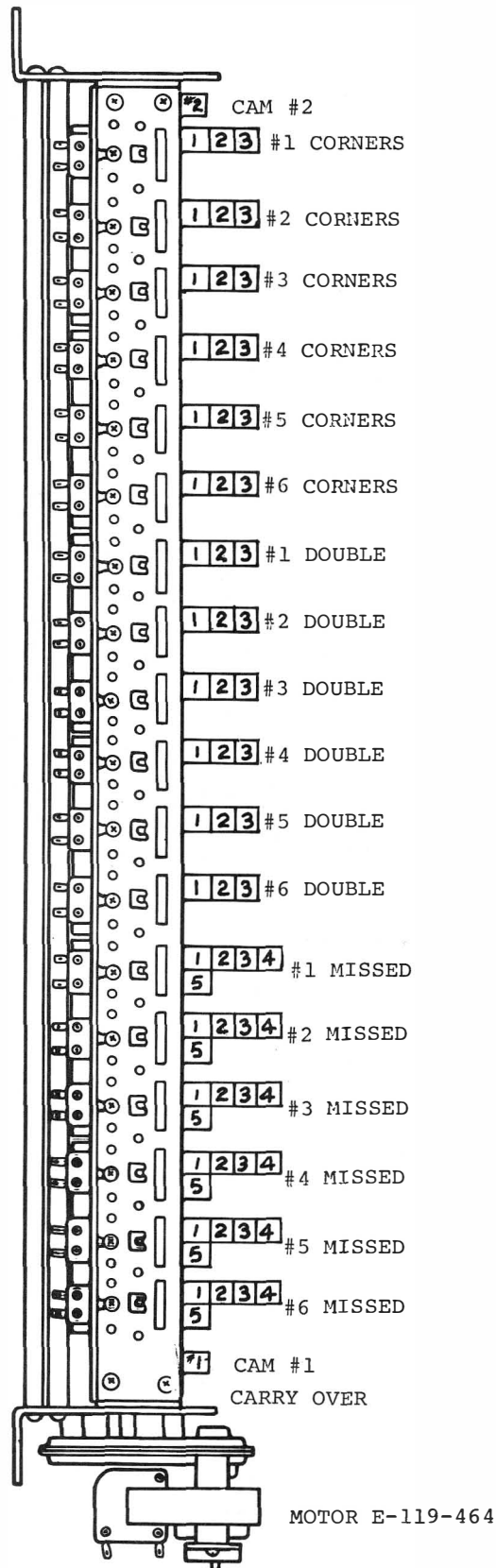

ALWAYS GIVE MODEL AND PART NO. WHEN ORDERING SERVICE PARTS

TRIP RELAY BANK 18

Switch/Coil	Part No.	Location on Diagram	Wire No.	Wire Color	Function
CAM #2 Switch	ASW-BO-1		NOT CONNECTED		
#1 Corners Relay Coil	D-27-425	A-28	70 13-4	Orange Red-Yellow	Trips thru Selection & Random Unit Disc
1. S.P.D.T.	ASW-B-3	H-14	27-8 50-4 30	Blue-Orange White Yellow	Completes Circuit to #1 Corner Lite
2. N.O.	ASW-B-1	F-18	61-7 41-5	Brown-Red Green-White#	Corner Winner on Card #1
3. N.O.		G-34	65-9 30	Brown-White Yellow	Completes a circuit to Card #2, Lite #15
#2 Corners Relay Coil	D-27-425	A-28	70 14-4	Orange Red Green	Trips thru selection & random unit disc
1. S.P.D.T.	ASW-B-3	H-15	23-8 51-4 30	Blue-Yellow White-Red Yellow	Completes Circuit to #2 Corner Lite
2. N.O.	ASW-B-1	F-18	61-7 43-5	Brown-Red Green-Yellow	Corner Winner on Card #2
3. N.O.		G-34	75-9 30	Orange-White Yellow	Completes a circuit to card #3, Lite #20
#3 Corners Relay Coil	D-27-425	A-28	70 15-4	Orange Red-White	Trips thru selection & random unit disc
1. S.P.D.T.	ASW-B-3	H-15	27-8 52-4 30	Blue-Orange White-Blue Yellow	Completes Circuit #3 Corner Lite
2. N.O.	ASW-B-1	F-19	61-7 45-5	Brown-Red Green-White	Corner Winner on Card #3
3. N.O.		G-35	74-9 30	Orange-Green Yellow	Completes a circuit to card #4, Lite #17
#4 Corners Relay Coil	D-27-425	A-28	70 18-4	Orange Red-Black	Trips thru Selection & Random Unit Disc
1. S.P.D.T.	ASW-B-3	H-16	23-8 14-3 30	Blue-Yellow Red-Green Yellow	Completes Circuit to #4 Corner Lite
2. N.O.	ASW-B-1	F-19	61-7 25-3	Brown-Red Blue-White	Corner Winner on Card #4
3. N.O.		G-35	78-9 30	Orange-Black Yellow	Completes a circuit to card #5, Lite #21
#5 Corners Relay Coil	D-27-425	A-29	70 20-4	Orange Blue	Trips thru Selection & Random Unit Disc
1. S.P.D.T.	ASW-B-3	H-16	27-8 54-4 30	Blue-Orange White-Green Yellow	Completes Circuit to #5 Corner Lite
2. N.O.	ASW-B-1	F-19	61-7 50-5	Brown-Red White	Corner Winner on Card #5
3. N.O.		G-35	81-9 30	Black-Red Yellow	Completes a circuit to card #6, Lite #22
#6 Corners Relay Coil	D-27-425	A-29	70 21-4	Orange Blue-Red	Trips thru Selection & Random Unit Disc
1. S.P.D.T.	ASW-B-3	H-17	23-8 56-4 30	Blue-Yellow White-Brown Yellow	Completes Circuit to #6 Corner Lite
2. N.O.	ASW-B-1	F-20	61-7 51-5	Brown-Red White-Red	Corner Winner on Card #6
3. N.O.		G-33	71-9 30	Orange-Red Yellow	Completes a circuit to card #1, Lite #10

TRIP RELAY BANK 18

Switch/Coil	Part No.	Location on Diagram	Wire No.	Wire Color	Function
#1 Double Relay Coil	D-27-425	A-33	70 23-4	Orange Blue-Yellow	Energized thru Double Win Relay & Double Delay Relay thru Search Disc 1-2-3
1. N. C.	ASW-B-2	G-5	48-10 36-7	Green-Black Yellow-Brown	Open Circuit to #1 Regular Lite
2. S.P.D.T.	ASW-B-3	H-6	95-5 65-6 30	Gray-White Brown-White Yellow	Completes Circuit to #1 Double Lite
3. S.P.D.T.	ASW-B-3	E-33	75-5 50-6 56-5	Orange-White White White-Brown	Energizes #2 Double Win Relay
#2 DOUBLE	D-27-425		70 25-4	Orange Blue-White	Energized thru double win relays & double delay relay thru search disc 1-2-3
1. N.C.	ASW-B-2	G-6	31-8 52-7	Orange-Red White-Blue	Hold-in circuit for score collect lites (#2)
2. T.	ASW-B-3	H-7	57-5 63-7 30	White-Orange Brown-Yellow Yellow	Lites #2 double
3. T.	ASW-B-3		74-5 51-8 56-5	Orange-Blue White-Red White-Brown	ENERGIES #2 DOUBLE WIN RELAY
#3 Double Relay Coil	D-27-425	A-34	70 10-3	Orange Red	Energized thru Double Win Relay & Dbl. Delay Relay thru Search Disc 1-2-3
1. N. C.	ASW-B-2	G-8	53-7 95-7	White-Yellow Gray-White	Open Circuit to #3 Regular Lite
2. S.P.D.T.	ASW-B-3	H-9	58-3 60-5 30	White-Black Brown Yellow	Completes Circuit to #3 Double Lite
3. S.P.D.T.	ASW-B-3	E-35	71-7 45-6 56-5	Orange-Red Green-White White-Brown	Energized #2 Double Win Relay
#4 Double Relay Coil	D-27-425	A-35	70 31-5	Orange Yellow-Red	Energized thru Dble Win Relay & Dbl. Delay Relay thru Search Disc 4-5-6
1. N. C.	ASW-B-2	G-10	98-7 90-6	Gray-Black Gray	Opens Circuit to #4 Regular Lite.
2. S.P.D.T.	ASW-B-3	H-10	21-5 38-4 30	Blue-Red Yellow-Black Yellow	Completes Circuit to #4 Double Lite.
3. S.P.D.T.	ASW-B-3	D-35	65-5 43-6 56-5	Brown-Red Green-Yellow White-Brown	Energized #2 Double Win Relay
#5 Double Relay Coil	D-27-425	A-36	70 36-5	Orange Yellow-Brown	Energized thru Dbl. Win Relay & Dbl. Delay Relay thru Search Disc 4-5-6
1. N. C.	ASW-B-2	G-11	83-6 75-7	Black-Yellow Orange-White	Opens Circuit to #5 Regular Lite
2. S.P.D.T.	ASW-B-3	H-11	53-5 41-4 30	White-Yellow Green-Red Yellow	Completes Circuit to #5 Double Lite
3. S.P.D.T.	ASW-B-3	D-36	63-6 40-6 56-5	Brown-Yellow Green White-Brown	Energize #2 Double Win Relay
#6 Double Relay Coil	D-27-425	A-37	70 21-6	Orange Blue-Red	Energized thru Dble. Win Relay & Dbl. Delay Relay thru Search Disc 4-5-6.
1. N. C.	ASW-B-2	G-12	18-6 21-7	Red-Black Blue-Red	Circuit to #6 Regular Lite
2. S.P.D.T.	ASW-B-3	H-12	61-5 93-3 30	Brown-Red Gray-Yellow Yellow	Completes Circuit to #6 Double Lite
3. S.P.D.T.	ASW-B-3	D-37	58-4 38-6 56-5	White-Black Yellow-Black White-Brown	Energize #2 Double Win Relay

TRIP RELAY BANK 18

Switch/Coil	Part No.	Location on Diagram	Wire No.	Wire Color	Function
#1 Missed Relay Coil	D-27-425	A-33	70 40 J	Orange Green	Energized thru 1-2-3 Search Disc & Double Delay Relay.
1. N. C.	ASW-B-2	B-33	40-7 40 J	Green Green J	Open Circuit to #1 Missed Trip Coil
2. N. C.	ASW-B-2	B-15	10-2 85	Red Black-White	Open Circuit to 1-2-3 Search Disc when Energized
3. N. C.	ASW-B-2	G-5	30 48-10	Yellow Green-Black	When Energized Open Circuit to #1 Regular Lite
4. S.P.D.T.	ASW-B-3	G-5	95-5 74-6 30	Gray-White Orange-Green Yellow	Completes Circuit to #1 Nothing Lite when Energized.
5. N. C.	ASW-B-2	H-6	65-6 78-5	Brown-White Orange-Black	Open Circuit to #1 Double Lite
#2 Missed Relay Coil	D-27-425	A-34	70 41J	Orange Green-Red	Energized thru 1-2-3 Search Disc & Double Delay Relay.
1. N. C.	ASW-B-2	B-34	41-7 41 J	Green-Red Green-Red	Open Circuit to #2 Missed Trip Coil.
2. N. C.	ASW-B-2	B-16	13-3 93	Red-Yellow Gray-Yellow	Open Circuit to 1-2-3 Search Disc
3. N. C.	ASW-B-2	G-7	30 31-8	Yellow Yellow-Red	When energized open circuit to #2 regular lite.
4. S.P.D.T.	ASW-B-3	G-7	57-5 36-4 30	White-Orange Yellow-Brown Yellow	Completes circuit #2 nothing lite.
5. N. C.	ASW-B-2	H-8	63-7 90	Brown-Yellow Gray	Open Circuit to #2 Double Lite
#3 Missed Relay Coil	D-27-425	A-35	70 43 J	Orange Green-Yellow	Energized thru 1-2-3 Search Disc & Double Delay Relay.
1. N. C.	ASW-B-2	B-35	43-7 43 J	Green-Yellow Green-Yellow	Open Circuit to #3 Missed Trip Coil
2. N. C.	ASW-B-2	B-17	14-2 98	Red-Green Gray-Black	Open Circuit to 1-2-3 Search Disc.
3. N. C.	ASW-B-2	G-8	30 53-7	Yellow White-Yellow	Open Circuit to #3 Regular Lite.
4. S.P.D.T.	ASW-B-3	G-8	58-3 83 30	White-Black Black-Yellow Yellow	Completes Circuit to #3 nothing lite.
5. N. C.	ASW-B-2	H-9	60-5 15-3	Brown Red-White	Open circuit to #3 Double Lite.
#4 Missed Relay Coil	D-27-425	A-35	70 45 J	Orange Green-White	Energized thru 4-5-6 Search Disc & Double Delay Relay
1. N. C.	ASW-B-2	B-35	45-7 45 J	Green-White Green-White	Open Circuit to #4 Missed Trip Coil
2. N. C.	ASW-B-2	B-19	18-5 80	Red-Black Black	Open Circuit to 4-5-6 Search Disc.
3. N. C.	ASW-B-2	G-9	30 98-7	Yellow Gray-Black	When Energized open circuit to #4 Regular Lite.
4. S.P.D.T.	ASW-B-3	G-10	21-5 13-6 30	Blue-Red Red-Yellow Yellow	Completes Circuit to #4 Nothing Lite
5. N. C.	ASW-B-2	H-11	38-4 25-2	Yellow-Black Blue-White	Open Circuit to #4 Double Lite
#5 Missed Relay Coil	D-27-425	A-36	70 48 J	Orange Green-Black	Energized thru 4-5-6 Search Disc
1. N. C.	ASW-B-2	B-36	48-7 48 J	Green-Black Green-Black	Open Circuit to #5 Missed Trip Coil.
2. N. C.	ASW-B-2	B-20	20-2 81	Blue Black-Red	Open Circuit to 4-5-6 Search Disc

TRIP RELAY BANK 18

Switch/Coil	Part No.	Location on Diagram	Wire No.	Wire Color	Function
3. N. C.	ASW-B-2	G-11	30 83-6	Yellow Black-Yellow	When energized open circuit to #5 Regular Lite
4. S.P.D.T.	ASW-B-3	G-11	53-5 63 30	White-Yellow Brown-Yellow Yellow	Completes Circuit to #5 Nothing Lite
5. N. C.	ASW-B-2	H-12	41-4 27	Green-Red Blue-Orange	Open Circuit to #5 Double Lite
#6 Missed Relay Coil	D-27-425	A-36	70 50 J	Orange White	Energized thru 4-5-6 Search Disc & Double Delay Relay
1. N. C.	ASW-B-2	B-36	50-7 50 J	White White	Open circuit to #6 Missed Trip Coil
2. N. C.	ASW-B-2	B-21	21-2 91-1	Blue-Red Gray-Red	Open Circuit to 4-5-6 Search Disc.
3. N. C.	ASW-B-2	G-13	30 18-6	Yellow Red-Black	When energized open circuit to #6 Regular Lite.
4. S.P.D.T.	ASW-B-3	G-13	61-5 43-4 30	Brown-Red Green-Yellow Yellow	Completes Circuit to #6 Nothing Lite
5. N. C.	ASW-B-2	H-14	93-5 57-4	Gray-Yellow White-Orange	Open Circuit to #6 Double Lite
Cam #1	ASW-B-1	E-21	30	Yellow	Carry Over to Motor
1. N. O.			90-1	Gray	
2. N. C.	ASW-B-20	J-17	51-7 41-2	White-Red Green-Red	Open Circuit to 6 volt circuit.
Motor	E-119-362	A-22	70 90-1	Orange Gray	Energized thru Shutter Cam #3 & 6

ALWAYS GIVE MODEL AND PART NO. WHEN ORDERING SERVICE PARTS

9 RELAY BANK

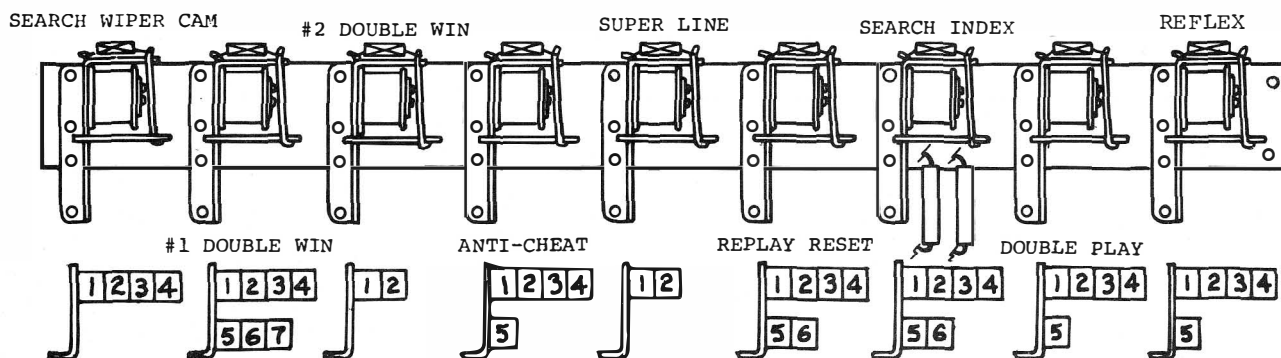

Switch/Coil	Part No.	Location on Diagram	Wire No.	Wire Color	Function
Search Wiper Coil	G-32-2500	A-24	70 50-1	Orange White	Energized during a winner search thru 1-2-3 or 4-5-6 search wiper lock cam switch.
1. N.O.	ASW-R1-3	F-37	21-3 48-4	Blue-Red Green-Black	Completes circuit to random motor.
2. N.O.	ASW-R1-3	F-1	10 P 20 P	Red Blue	Energized control unit motor during winner search
3. N.C.	ASW-R2-5	F-5	80-9 27-4	Black Blue-Orange	Opens the coin & game start circuit
4. S.P.D.T.	ASW-R3-6	E-27	54-2 93-7 38-3	White-Green Gray-Yellow Yellow-Black	Energizes double win relay #1 thru random disc search index & dbl. play relays.
Double Win Relay #1	G-30-1500	A-27	70 43	Orange Green-Yellow	Energizes thru random unit disc.
1. N.O.	ASW-R1-8	A-27	61 43	Brown-Red	Hold in circuit for double win relay #1
2. N.O.	ASW-R1-3	B-33	95-4 23-4	Gray-White Blue-Yellow	Energizes #1 Double Trip
3. N.O.	ASW-R1-3	B-33	25-4 83-4	Blue-White Black-Yellow	Energizes #2 Double Trip
4. N.O.	ASW-R1-3	B-34	90-4 10-3	Gray Red	Energizes #3 double trip.
5. N.O.	ASW-R1-3	B-35	85-4 31-5	Black-White Yellow-Red	Energizes #4 double trip
6. N.O.	ASW-R1-3	B-36	80-4 36-5	Black Yellow-Brown	Energizes #5 double trip.
7. N.O.	ASW-R1-3	B-36	20-5 21-6	Blue Blue-Red	Energizes #6 double trip.
Double Win Relay #2	G-33-2800	A-37	70 56-5	Orange White-Brown	Energizes double win relay #2 thru 4-5-6 search disc & 4-5-6 double trips.
1. N.O.	ASW-R1-3	B-14	78 40-2	Orange-Black Green	Energizes replay cam index relay
2. S.P.D.T.	ASW-R3-6	A-15	13-2 81-1 14-8	Red-Yellow Black-Red Red-Green	Completes circuit to 1-2-3 & 4-5-6 replay counter step up coils fo double.
Anti Cheat Relay	G-32-2500	A-4	70 15-7	Orange Red-White	Energized thru control unit cam #4 switch.
1. N.O.	ASW-R1-8	C-4	30 15-7	Yellow Red-White	Hold in circuit for anti cheat relay.
2. N.O.	ASW-R1-3	H-19	14-10 91-10	Red-Green Gray-Red	Completes circuit to 17 volt cards lite.
3. N.C.	ASW-R2-5	E-6	63-4 27-4	Brown-Yellow Blue-Orange	Open circuit to start relay
4. S.P.D.T.	ASW-R3-6	H-19	13-10 74-10 41-10	Red-Yellow Orange-Green Green-Red	Completes circuit to 6 volt lites.
5. S.P.D.T.	ASW-R3-6	D-5	75-4 56-2 90-2	Orange-White White-Brown Gray	Completes circuit to start relay thru replay button when credits on replay register.

9 RELAY BANK

Switch/Coil	Part No.	Location on Diagram	Wire No.	Wire Color	Function
Super Line Relay	G-33-2800	A-17	70 57	Orange White-Orange	Energized thru super line trip switches
1. N. O.	ASW-R1-3a	D-15	52-2 53-2	White-Blue White-Yellow	Completes a 4 in line pay circuit.
2. S.P.D.T.	ASW-R3-6a	D-17	53-2 50-8 48	White-Yellow White Green-Black	Completes a 4 in line pay circuit for corners.
Replay Reset Relay	G-31-2000	A-5	70 75-4	Orange Orange-White	Energized when there are credits on replay register thru key switch.
1. N. O.	ASW-R1-3	D-5	56-2 75-4	White-Brown Orange-White	Hold in circuit for replay reset relay
2. N. O.	ASW-R1-3	F-2	10 P 20 P	Red Blue	Energizes control unit motor.
3. N. C.	ASW-R2-5	D-14	30 93-2	Yellow Gray-Yellow	Opens circuit to replay register step up coil.
4. N. C.	ASW-R2-5	B-5	10-1 98-3	Red Gray-Black	Opens circuit to start relay
5. N. C.	ASW-R2-5	B-23	18-2 27-3	Red-Black Blue-Orange	Opens a circuit to 1-2-3 search wiper lock coil.
6. S.P.D.T.	ASW-R3-6	C-5	90-5 65-7 74-1	Gray Brown-White Orange-Green	Opens a circuit to reflex in coil.
Search Index Relay Coil	G-31-2000	A-33	70 81-5	Orange Black-Red	Energized thru 1-2-3 or 4-5-6 search index sw. on control motor.
1. N. O.	ASW-R1-8	E-26	93-7 95	Gray-Yellow Gray-White	Completes a circuit to regular or double switches
2. N. O.	ASW-R1-3	H-5	50-3 48-3	White Green-Black	Completes a circuit to double box lite.
3. N. O.	ASW-R1-3	H-5	78-6 48-3	Orange-Black Green-Black	Completes a circuit from 1-2-3 & 4-5-6 search disc to dbl. box lite.
4. N. O.	ASW-R1-3	E-27	18-8 58-2	Red-Black White-Black	Completes a circuit to random disc.
5. N. C. Resistor	ASW-R2-5 E-104-33	A-19	71-3 R 98-5	Orange-Red Resistor Gray-Black	Opens a circuit to the 4-5-6 Search index coil.
6. N. C. Resistor	ASW-R2-5 E-104-33	C-15	91-2 R 85-5	Gray-Red Resistor Black-White	Opens a circuit to the 1-2-3 search index coil.
Double Play Relay Coil	G-31-2000	A-26	70 61	Orange Brown-Red	Energized thru double button sw.
1. N. O.	ASW-R1-8	C-27	71-1 61	Orange-Red Brown-Red	Completes a circuit to 4-5-6 search disc.
2. N. O.	ASW-R1-3	F-27	58-2 38-3	White-Black Yellow-Black	Completes a circuit to random disc thru search index relay.
3. N. C.	ASW-R2-5	B-38	15-6 14-9	Red-White Red-Green	Opens a circuit to random motor.
4. N. C.	ASW-R2-5	C-26	23-5 56	Blue-Yellow White-Brown	Opens a circuit to regular win relay.
5. N. C.	ASW-R2-5	D-25	21-3 31-6	Blue-Red Yellow-Red	Opens a circuit to double delay relay.
Reflex Relay Coil	G-32-2500	A-32	70 91	Orange Gray-Red	Energized thru reflex cam switch.
1. N. O.	ASW-R1-8	E-32	57-3 91	White-Orange Gray-Red	Hold in circuit for reflex relay.
2. N. O.	ASW-R1-3	D-29	52-5 21-7	White-Blue Blue-Red	Completes a circuit from selection disc to random disc.
3. N. O.	ASW-R1-3	D-30	50-10 21-7	White Blue-Red	Completes a circuit from selection disc to random disc.
4. N. O.	ASW-R1-3	C-27	25 43	Blue-White Green-Yellow	Energizes double win relay #1.
5. N. O.	ASW-R1-3	D-28	36-6 78-7	Yellow-Brown Orange-Black	Completes a circuit from selection disc to random disc.

5 RELAY BANK

DOUBLE DELAY FLASH CONTROL REG WIN START MULTI PLAY

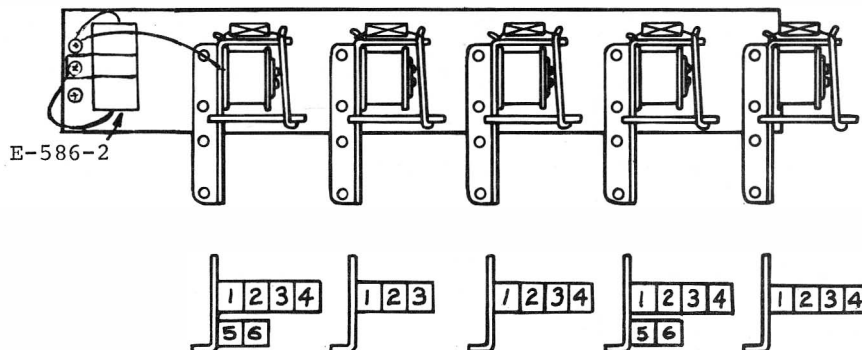

Switch/Coil	Part No.	Location on Diagram	Wire No.	Wire Color	Function
Double Delay Relay Coil	G-35-5200	A-25	70 31-6	Orange Yellow-Red	Energized when power is on.
1. S.P.D.T.	ASW-R3-6	C-33	40-7 75-5 95-4	Green Orange-White Gray-White	Checks for double or nothing on card #1.
2. S.P.D.T.	ASW-R3-6	C-34	41-7 74-5 83-4	Green-Red Orange-Green Black-Yellow	Checks for double or nothing on card #2.
3. S.P.D.T.	ASW-R3-6	C-35	43-7 71-7 90-4	Green-Yellow Orange-Red Gray	Checks for double or nothing on card #3.
4. S.P.D.T.	ASW-R3-6	C-35	45-7 65-7 85-4	Green-White Brown-White Black-White	Checks for double or nothing on card #4.
5. S.P.D.T.	ASW-R3-6	C-36	50-7 58-4 20-5	White White-Black Blue	Checks for double or nothing on Card #5.
6. S.P.D.T.	ASW-R3-6	C-37	48-7 63-6 80-4	Green-Black Brown-Yellow Black	Checks for double or nothing on card #6.
Flash Relay	AS-2659-461	A-39	70 83-7	Orange Black-Yellow	Energized thru start relay switch
1. N.O.	ASW-R1-8	B-38	83-7 74-4	Black-Yellow Orange-Green	Hold in circuit for flash control relay
2. N.O.	ASW-R1-3	G-3	15-5 30	Red-White Yellow	Completes circuit to B-3 and B-4 flash lites
3. N.C.	ASW-R2-5	G-18	30 61-8	Yellow Brown-Red	Opens a circuit to corner & super line flashing lites
Reg. Win Relay Coil	G-32-2500	A-26	70 56	Orange White-Brown	Energized thru regular button sw. to collect winner.
1. N.O.	ASW-R1-3	C-14	78 40-2	Orange-Black Green	Completes a circuit to replay cam coil.
2. N.C.	ASW-R2-5	H-5	20 50-3	Blue White	Opens a circuit to double box lite.
3. N.C.	ASW-R2-5	C-27	65-8 57-7	Brown-White White-Orange	Open circuit to double play relay.
4. S.P.D.T.	ASW-R3-6	D-26	71-1 95 23-5	Orange-Red Gray-White Blue-Yellow	Completes a circuit to 4-5-6 search disc.

5 RELAY BANK

Switch/Coil	Part No.	Location on Diagram	Wire No.	Wire Color	Function
Start Relay Relay Coil		A-5	70 48-2	Orange Green-Black	Energized thru front door coin sw. or replay button switch.
1. N.O.	ASW-R1-8	E-8	80-9 90-3	Black Gray	Hold in circuit for start relay.
2. N.O.	ASW-R1-3	B-8	58 98-3	White-Black Gray-Black	Completes circuit to shutter motor.
3. N.O.	ASW-R1-3	A-32	54-7 93-8	White-Green Gray-Yellow	Completes a circuit to "X" relay thru select B-3 trip switch.
4. N.O.	ASW-R1-3	C-39	83-7 23-7	Black-Yellow Blue-Yellow	Completes a circuit to flash control relay.
5. N.C.	ASW-R2-5	E-32	95-1 91	Gray-White Gray-Red	Opens a circuit to reflex relay.
6. N.C.	ASW-R2-5	E-9	21-3 50-2	Blue-Red White	Opens a circuit to timer unit step up coil.
Multiplay Replay	G-30-1500	A-8	70 78-1	Orange Orange-Black	Energized thru coin switch.
1. N.O.	ASW-R1-3	E-8	93-4 78-1	Gray-Yellow Orange-Black	Hold in circuit for multiplay relay.
2. N.O.	ASW-R1-3	D-6	53-8 10-1	White-Yellow Red	Completes circuit to start relay.
3. N.C.	ASW-R2-5	B-5	65-7 50	Brown-White White	Opens circuit to replay register step up coil.
4. S.P.D.T.	ASW-R3-6	C-13	41-6 14 31-2	Green-Red Red-Green Yellow-Red	Energizes replay register step up

ALWAYS GIVE MODEL AND PART NO. WHEN ORDERING SERVICE PARTS

SEARCH RELAY BANK 5

#1 SEARCH #2 SEARCH #3 SEARCH #4 SEARCH #5 SEARCH

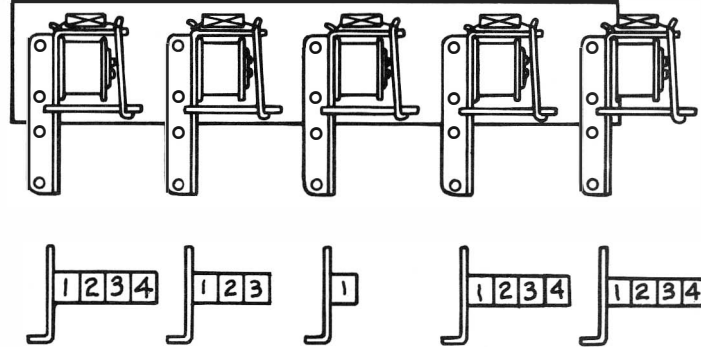

Switch/Coil	Part No.	Location on Diagram	Wire No.	Wire Color	Function
#1 Search Relay Coil	G-28-850	J-30	10 20-1	Red Blue	Energizes thru 1, 2, 3 & 4, 5, 6 Search disc.
1. N. O.	ASW-R1-3	E-15	75-2 52-2	Orange-White White-Blue	Winner circuit for 3 in line.
2. N. O.	ASW-R1-3	F-18	60-7 85-2	Brown Black-White	Winner circuit for 5 in line
3. N. O.	ASW-R1-3	E-17	50-8 85-2	White Black-White	Winner circuit for 4 in line.
4. N. O.	ASW-R1-3	G-15	25-6 23-6	Blue-White Blue-Yellow	Winner Circuit for corners.
#2 Search Relay Coil	G-28-850	J-31	10 31	Red Yellow-Red	Energizes thru 1,2,3 & 4, 5, 6 Search Disc.
1. N. O.	ASW-R1-3	F-16	71-2 74-2	Orange-Red Orange-Green	Winner circuit for 4 & 5 in line.
2. N. O.	ASW-R1-3	E-16	75-2 74-2	Orange-White Orange-Green	Winner circuit for 3 in line.
3. N. O.	ASW-R1-3	C-16	25-6 27-6	Blue-White Blue-Orange	Winner circuit for corners.
#3 Search Relay Coil	G-28-850	J-31	10 36	Red Yellow-Brown	Energized thru 1,2,3 & 4, 5, 6 Search Disc.
1. N. O.	ASW-R1-3	F-15	23-6 74-2	Blue-Yellow	Winner circuit for 3, 4 & 5 in line.
#4 Search Relay Coil	G-28-850	J-31	10 38	Red Yellow-Black	Energizes thru 1, 2, 3 & 4, 5, 6 Search disc.
1. N. O.	ASW-R1-3	E-16	75-2 52-2	Orange-White White-Blue	Winner circuit for 3 in line.
2. N. O.	ASW-R1-3	E-16	74-2 81-2	Orange-Green Black-Red	Winner circuit for 3 in line.
3. N. O.	ASW-R1-3	F-17	85-2 71-2	Black-White Orange-Red	Winner circuit for 4 & 5 in line.
4. N. O.	ASW-R1-3	G-16	14-6 27-6	Red-Green Blue-Orange	Winner circuit for corners
#5 Search Relay Coil	G-28-850	J-32	10 40	Red Green	Energizes thru 1,2,3 & 4, 5, 6 search disc.
1. N. O.	ASW-R1-3	E-17	52-2 81-2	White-Blue Black-Red	Winner circuit for 3 in line.
2. N. O.	ASW-R1-3	E-18	50-8 85-2	White Black-White	Winner circuit for 4 in line.
3. N. O.	ASW-R1-3	D-18	60-7 48	Brown Green-Black	Winner circuit for 5 in line.
4. N. O.	ASW-R1-3	F-18	61-7 14-6	Brown-Red Red-Green	Winner circuit for corners.

SPOT SELECTOR ASSEMBLY

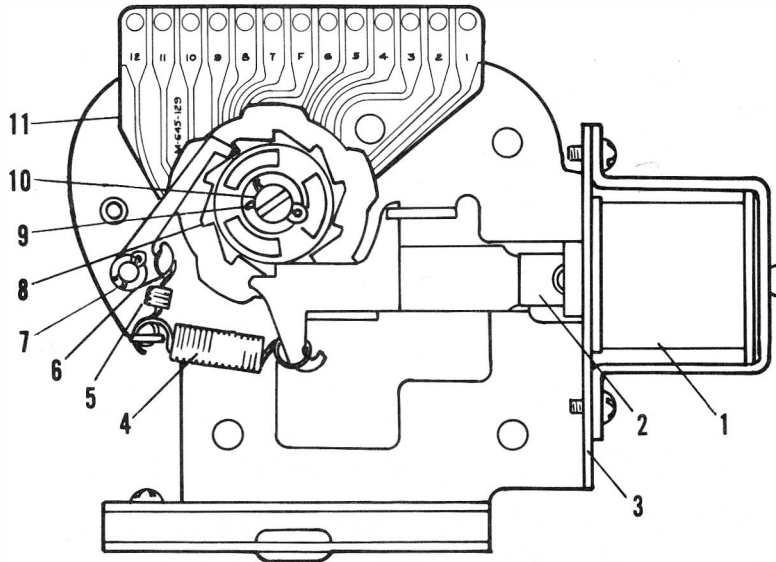

EXTERNAL WIRE CONNECTIONS			JUMPER WIRE CONNECTIONS	
FROM LITES	TO	WIRE NO.	FROM	TO
#22 CARD #6	#1	81-9	#1	#7
#21 CARD #5	#2	78-9	#2	#8
#17 CARD #4	#3	74-9	#3	#9
#20 CARD #3	#4	75-9	#4	#10
#15 CARD #2	#5	65-9	#5	#11
#16 CARD #1	#6	71-9	#6	#12
FROM SEL. B-3 TRIP SW.	F	36-8		

DESCRIPTION	PART NO.
1. COIL	CT-28-1100
2. DRIVE PAWL	AS-2293-6
3. BASE PLATE	A-2214-33
4. EXTENSION SPRING	SP-100-80
5. EXTENSION SPRING	SP-100-258
6. HOLDING PAWL	C-708
7. HAIR PIN	M-254
8. RATCHET - 12 TOOTH	C-704-1
9. HAIR PIN	M-254-1
10. PIN	S-2028
11. SELECTOR DISC	W-999-40

ALWAYS GIVE MODEL AND PART NO. WHEN ORDERING SERVICE PARTS

SELECTION UNIT DISC

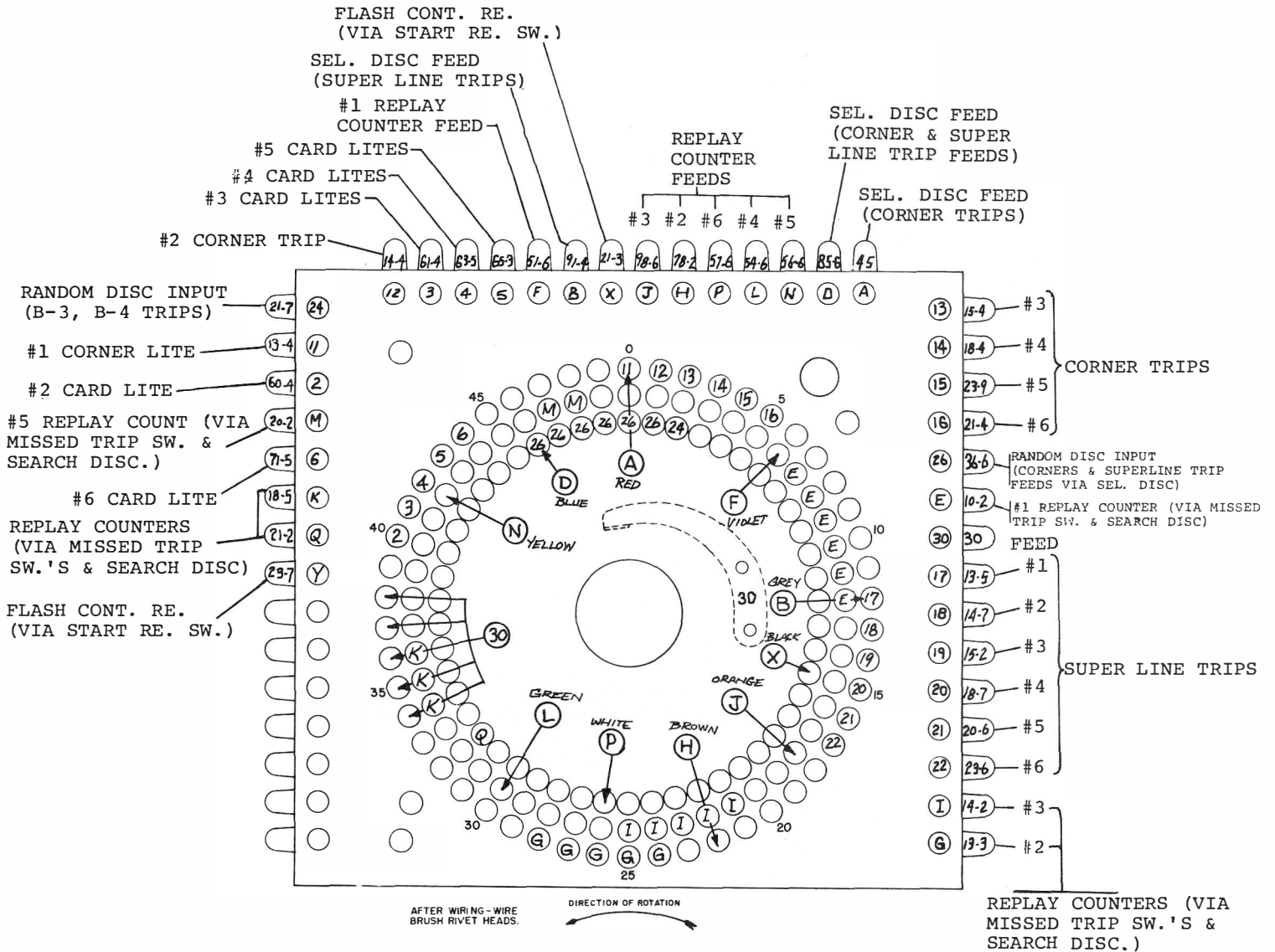

DISC ASSEMBLY W-764-20
WIPER ASSEMBLY AS-1046-818

SELECTION UNIT ASSEMBLY					
Step Up Coil	B-25-925	A-22	70 27-5	Orange Blue-Orange	Energized by control unit cam #4 Sw.
Reset Coil	C-28-1100	D-23	70 85-3	Orange Black-White	Energized thru shutter cam #3

ALWAYS GIVE MODEL AND PART NO. WHEN ORDERING SERVICE PARTS

RANDOM UNIT DISC

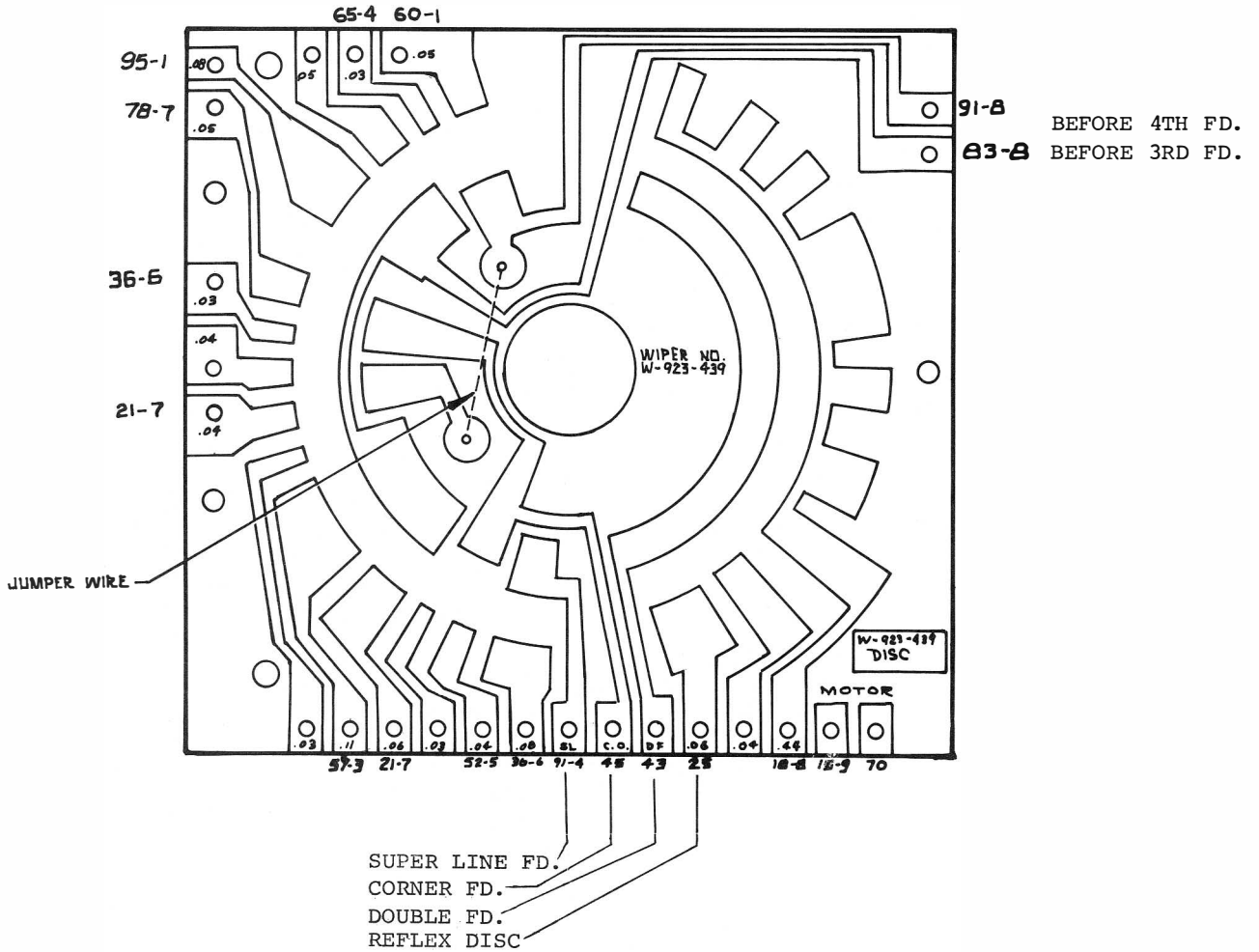

RANDOM UNIT					
Random Disc Motor	E-119-427	A-38	70 15-6	Orange Red-White	Energized thru search wiper relay switch or control unit timer index cam switch.

ALWAYS GIVE MODEL AND PART NO. WHEN ORDERING SERVICE PARTS

REFLEX UNIT DISC

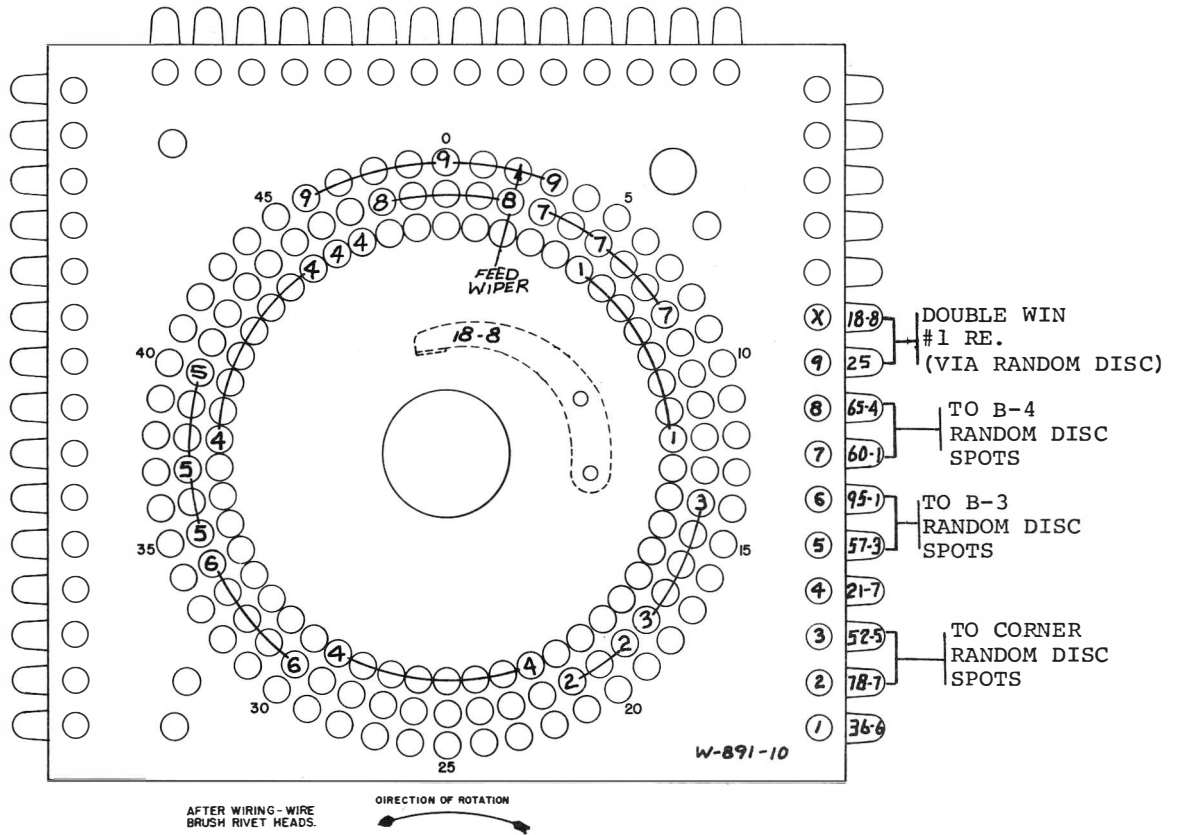

DISC ASSEMBLY W-891-10
WIPER ASSEMBLY AS-1046-818

REFLEX UNIT					
Reflex in Coil	EA-32-1550	A-5	70 90-5	Orange Gray	Energized thru control unit cam #3 pin switch.
Reflex Out Coil	EA-30-1150	A-13	70 41-6	Orange Green-Red	Energized thru winner circuit.
Cam Switch N. O.	ASW-C1-27	F-32	21-3 95-1	Blue-Red Gray-White	Completes a circuit to reflex relay.
Cam Switch N. C.	ASW-C2-6	F-32	21-3 57-3	Blue-Red White-Orange	Opens a circuit to reflex relay.

ALWAYS GIVE MODEL AND PART NO. WHEN ORDERING SERVICE PARTS

TIMER UNIT DISC

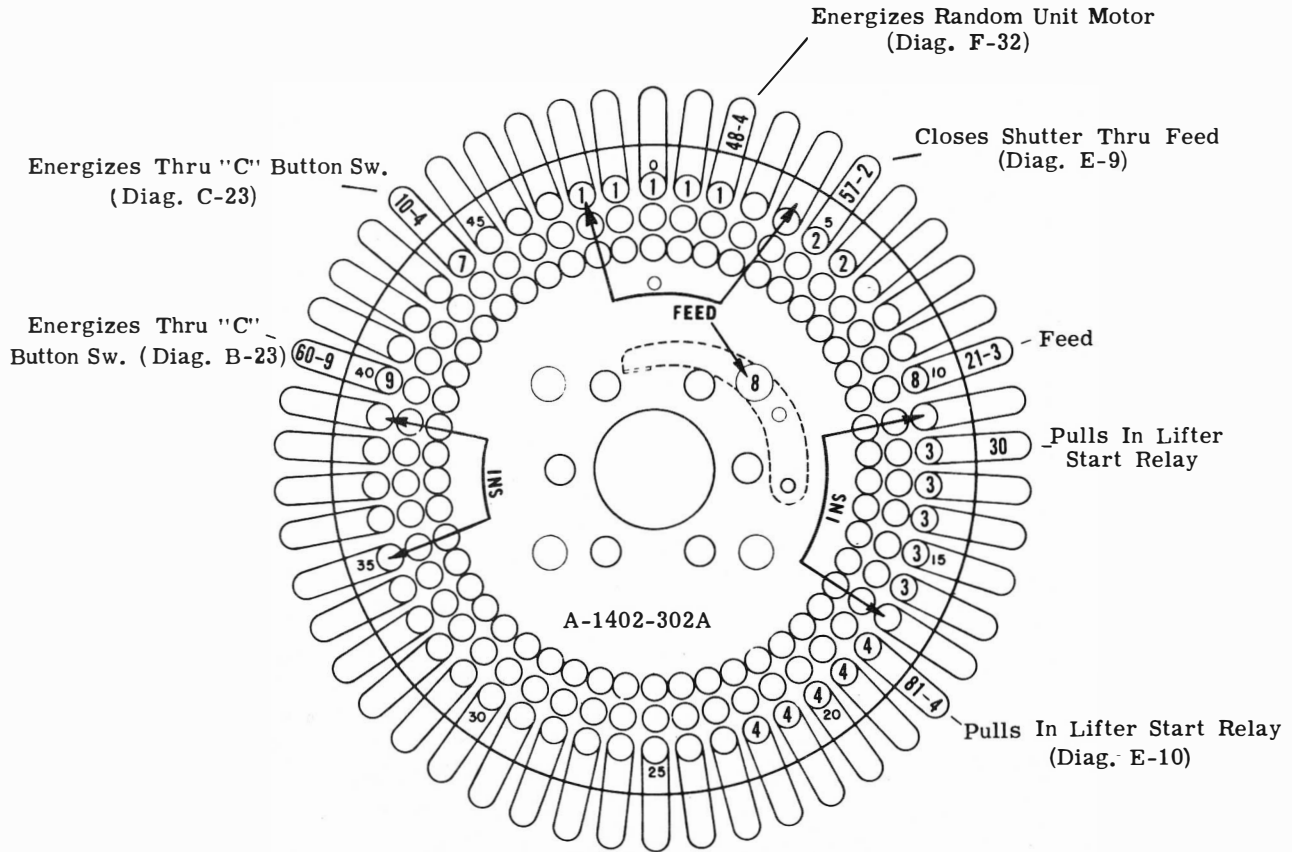

Viewed From Wiring Side

DIRECTION OF ROTATION

Description	Part No.
Complete Unit	AS-1110-49ND
Ratchet & Shaft	C-1050-5-38
Reset Coil	C-28-1100
Step-Up Coil	B-25-925
Step-Up Arm	A-1765-4
Disc (Wired)	W-1151-2
Wiper Assembly	AS-1046-695

Switch/Coil	Part No.	Location on Diagram	Wire No.	Wire Color	Function
			TIMER UNIT		
Step Up Coil	B-25-925	A-9	70	Orange	Energized thru timer disc & control unit cam #1 Sw.
Reset Coil	C-28-1100	A-25	70	Orange	Energized thru shutter cam #3 sw. & "C" button sw.
			98 J	Gray-Black	
Open at A. Zero Sw. N. O.	ASW-U2	A-25	98-1	Gray-Black	Completes a circuit to timer reset coil.
			98 J	Gray-Black	
Open at B. Zero Sw. N. O.	ASW-U2-1	C-12	61-3	Brown-Red	Completes a circuit to ball lifter motor.
			74-3	Orange-Green	
Open at C. 5th Step Sw. N. C.	ASW-U2-6	G-2	10 P	Red	Opens a circuit (at 5th step) to the control unit motor.
			70 P	Orange	
Open at D. Top Sw. N. C.	ASW-U2-5	A-8	60-2	Brown	Opens a circuit to the timer step up coil.
			60 J	Brown	

CARD NO. 1 REPLAY UNIT DISC

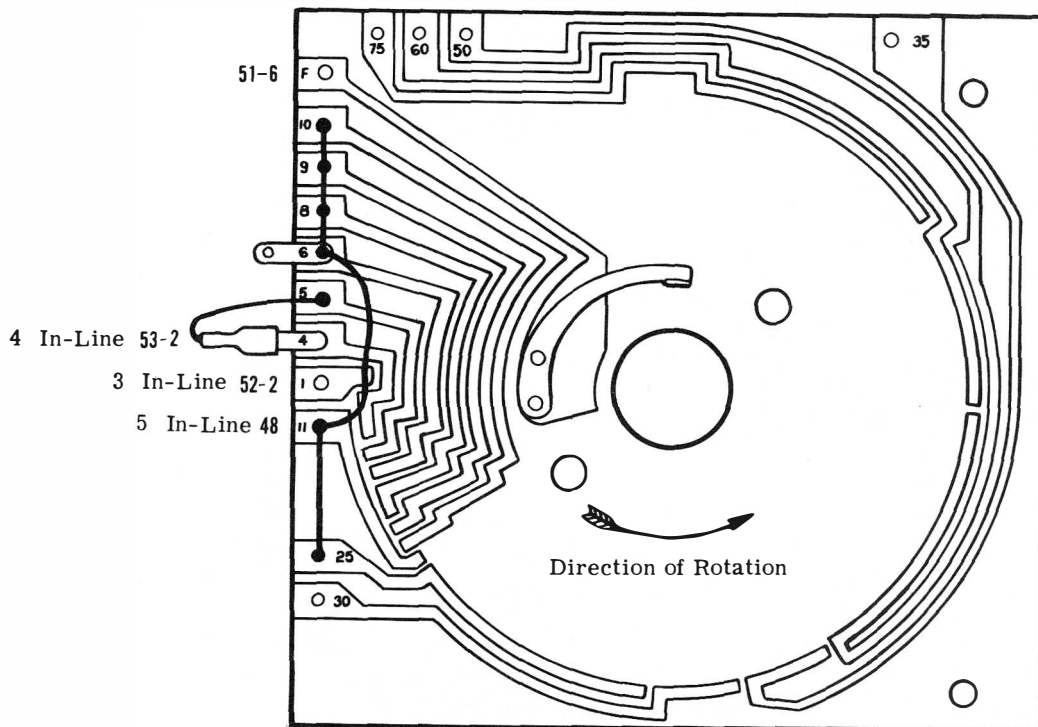

Viewed From Wiper Side

Description	Part No.
Complete Unit	AS-1022-128
Ratchet & Shaft	C-100-76
Reset Coil	C-28-1100
Step-Up Coil	B-25-925
Step-Up Plunger	AS-1366-3
Step-Up Arm	A-1765-8
Disc (Wired)	W-923-269
Wiper Assembly	AS-1046-664

REPLAY COUNTER #1					
Step Up Coil	B-25-925	A-15	58-6 81-1	White-Black Black-Red	Energized thru winner search circuit.
Reset Coil	C-28-1100	B-22	70 85-3	Orange Black-White	Energized thru shutter cam #3
S. P. D. T.	ASW-U3	H-6	95-5 60-10 36-7	Gray-White Brown Yellow-Brown	Directs circuit to #1 regular or double lites

CARD NO. 2 REPLAY UNIT DISC

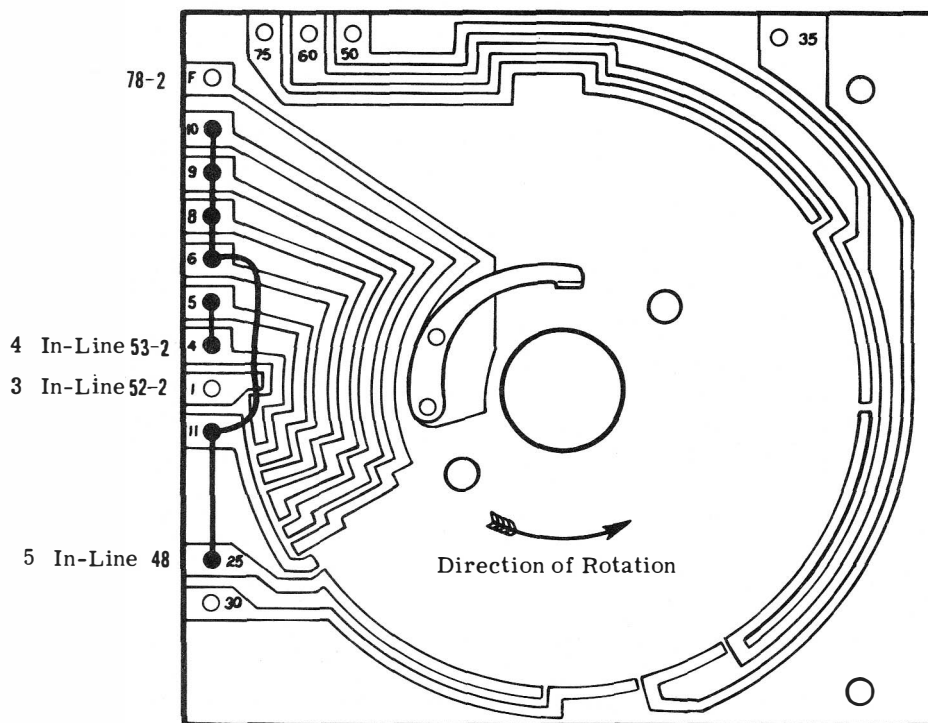

Viewed from Wiper Side

Description	Part No.
Complete Unit	AS-1022-129
Ratchet & Shaft	C-100-76
Reset Coil	C-28-1100
Step-Up Coil	B-25-925
Step-Up Plunger	AS-1366-3
Step-Up Arm	A-1765-8
Disc (Wired)	W-923-238
Wiper Assembly	AS-1046-664

REPLAY COUNTER #2					
Step Up Coil	B-25-925	A-16	60-5 81-1	Brown Black-Red	Energized thru winner search circuit.
Reset Coil	C-28-1100	A-22	70 85-3	Orange Black-White	Energized thru shutter cam #3.
S. P. D. T.	ASW-U3	H-7	57-5 61-10 52-7	White-Orange Brown-Red White-Blue	Directs circuit to #2 regular or double lites.

CARD NO. 3 REPLAY UNIT DISC

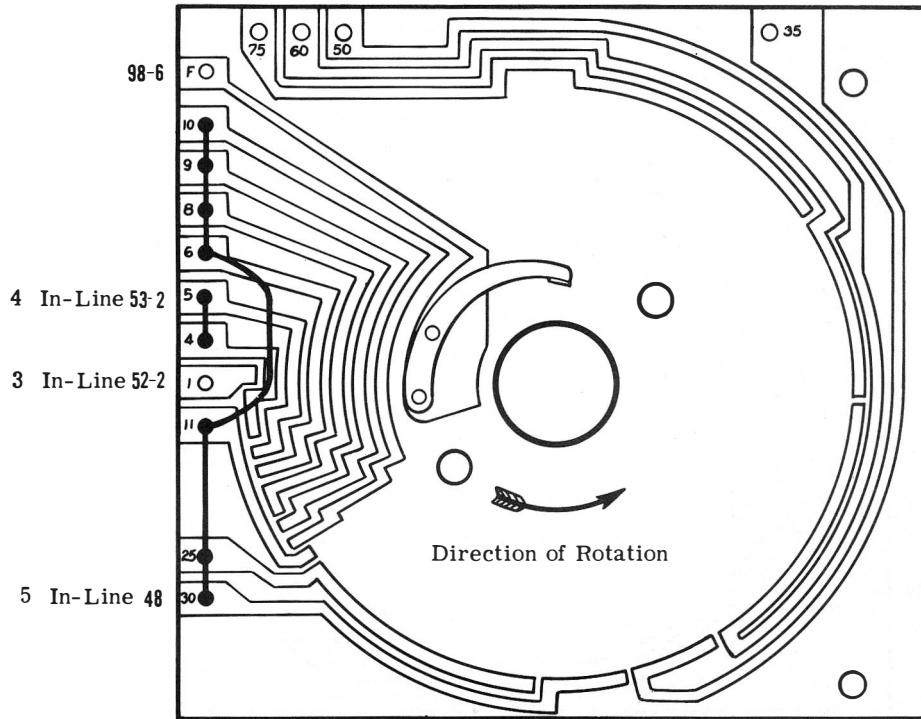

Viewed From Wiper Side

Description	Part No.
Complete Unit	AS-1022-130
Ratch & Shaft	C-100-76
Reset Coil	C-28-1100
Step-Up Coil	B-25-925
Step-Up Plunger . . .	AS-1366-3
Step-Up Arm	A-1765-8
Disc (Wired)	W-923-265
Wiper Assembly . . .	AS-1046-664

REPLAY COUNTER #3					
Step Up Coil	B-25-925	A-16	61-6 81-1	Brown-Red Black-Red	Energized thru winner search circuit.
Reset Coil	C-28-1100	A-22	70 85-3	Orange Black-White	Energized thru shutter cam #3/
S. P. D. T.	ASW-U3	H-8	58-3 63-10 95-7	White-Black Brown-Yellow Gray-White	Directs circuit to #3 regular or double lites.

CARD NO. 4 REPLAY UNIT DISC

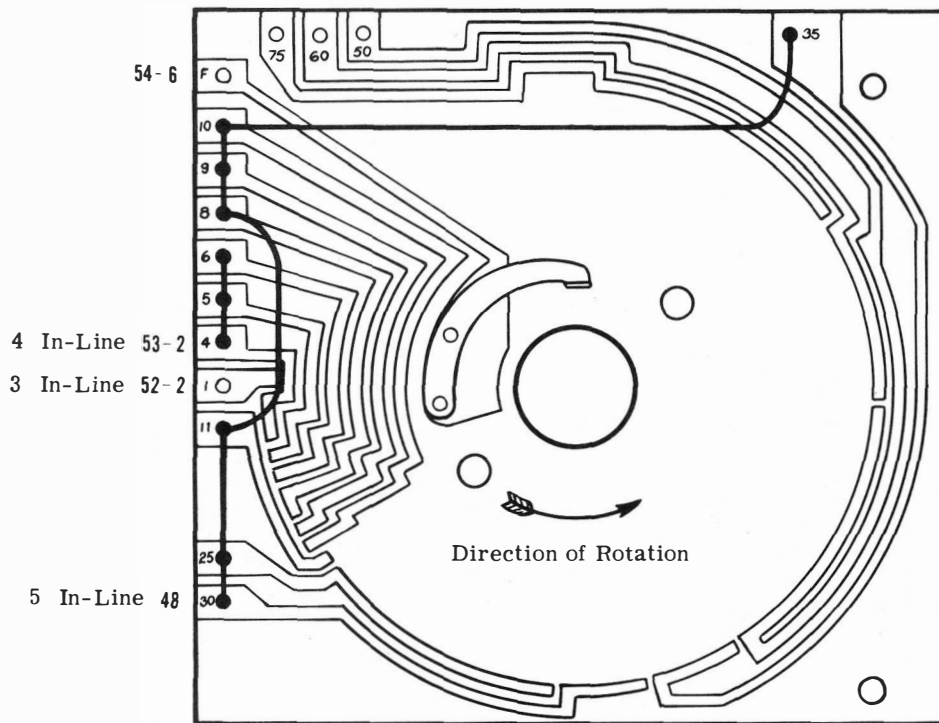

Viewed From Wiper Side

Description	Part No.
Complete Unit	AS-1022-131
Ratchet & Shaft	C-100-76
Reset Coil	C-28-1100
Step-Up Coil	B-25-925
Step-Up Plunger	AS-1366-3
Step-Up Arm	A-1765-8
Disc (Wired)	W-923-266
Wiper Assembly	AS-1046-664

REPLAY COUNTER #4					
Step Up Coil	B-25-925	A-19	63-3 81-1	Brown-Yellow Black-Red	Energized thru winner search circuit
Reset Coil	C-28-1100	B-23	70 85-3	Orange Black-White	Energized thru shutter cam #7.
S. P. D. T.	ASW-U3	H-9	21-5 65-10 90-6	Blue-Red Brown-White Gray	Directs circuit to #3 regular or double lites.

CARD NO. 5 REPLAY UNIT DISC

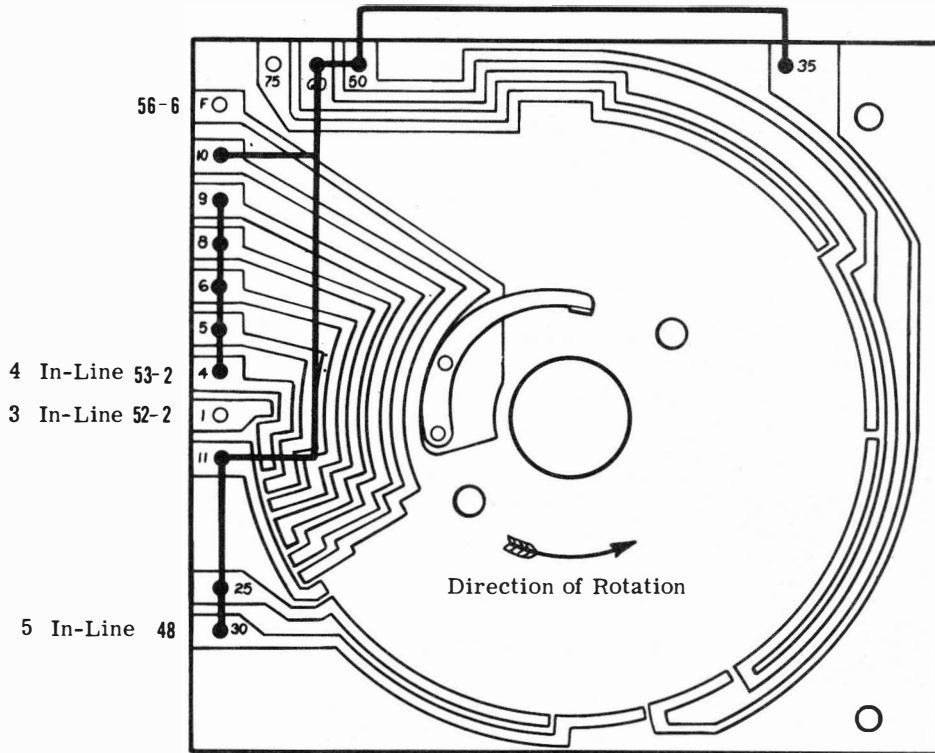

Viewed From Wiper Side

Description	Part No.
Complete Unit	AS-1022-132
Ratchet & Shaft	C-100-76
Reset Coil	C-28-1100
Step-Up Coil	B-25-925
Step-Up Plunger	AS-1366-3
Step-Up Arm	A-1765-8
Disc (Wired)	W-923-267
Wiper Assembly	AS-1046-664

REPLAY COUNTER #5					
Step Up Coil	B-25-925	A-20	71 81-1	Orange-Red Black-Red	Energized thru Winner Search Circuit.
Reset Coil	C-28-1100	A-23	70 85-3	Orange Black-White	Energized thru shutter cam #7.
S. P. D. T.	ASW-U3	H-11	53-5 95-9 75-7	White-Yellow Gray-White Orange-White	Directs circuit to #5 regular or double lites

ALWAYS GIVE MODEL AND PART NO. WHEN ORDERING SERVICE PARTS

CARD NO. 6 REPLAY UNIT DISC

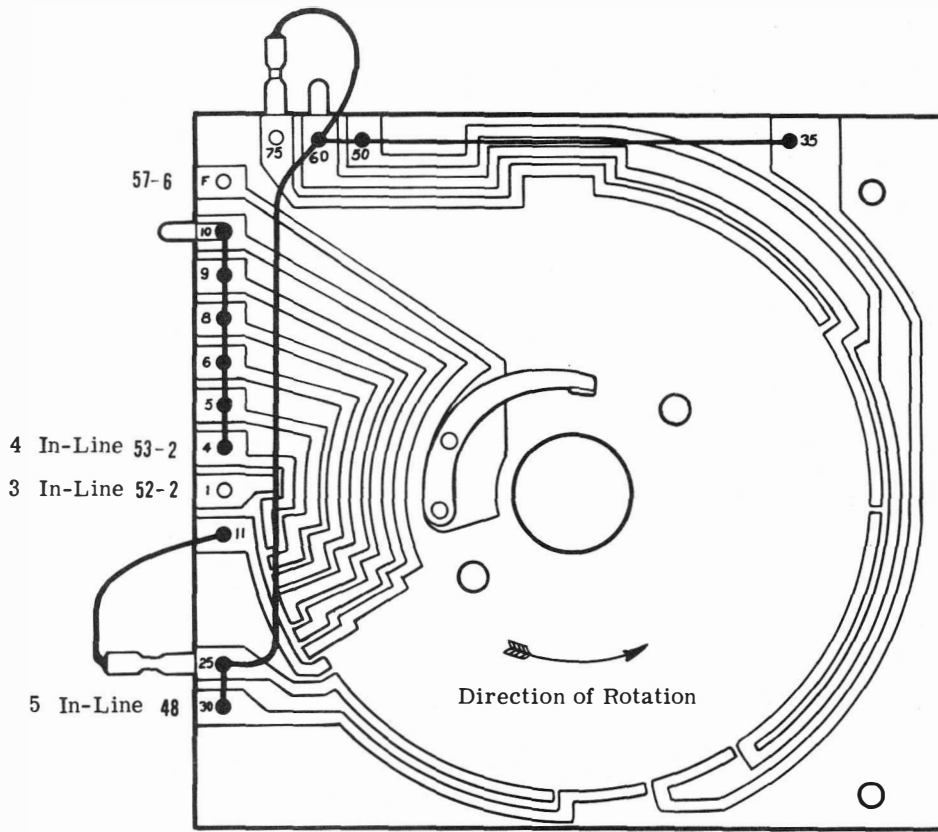

Viewed from Wiper Side

Description	Part No.
Complete Unit	AS-1022-133
Ratchet & Shaft	C-100-76
Step-Up Coil	B-25-925
Step-Up Plunger	AS-1366-3
Step-Up Arm	A-1765-8
Disc (Wired)	W-923-268
Wiper Assembly	AS-1046-664
Reset Coil	C-28-1100

REPLAY COUNTER # 6					
Step Up Coil	B-25-925	A-21	74 81-1	Orange-Green Black-Red	Energized thru winner search circuit.
Reset Coil	C-28-1100	A-23	70 85-3	Orange Black-White	Energized thru shutter cam #7.
S. P. D. T.	ASW-U3	H-12	61-5 83-5 20-7	Brown-Red Black-Yellow Blue	Directs circuit to #6 regular or double lites.

ALWAYS GIVE MODEL AND PART NO. WHEN ORDERING SERVICE PARTS

PANEL SHUTTER ASSEMBLY

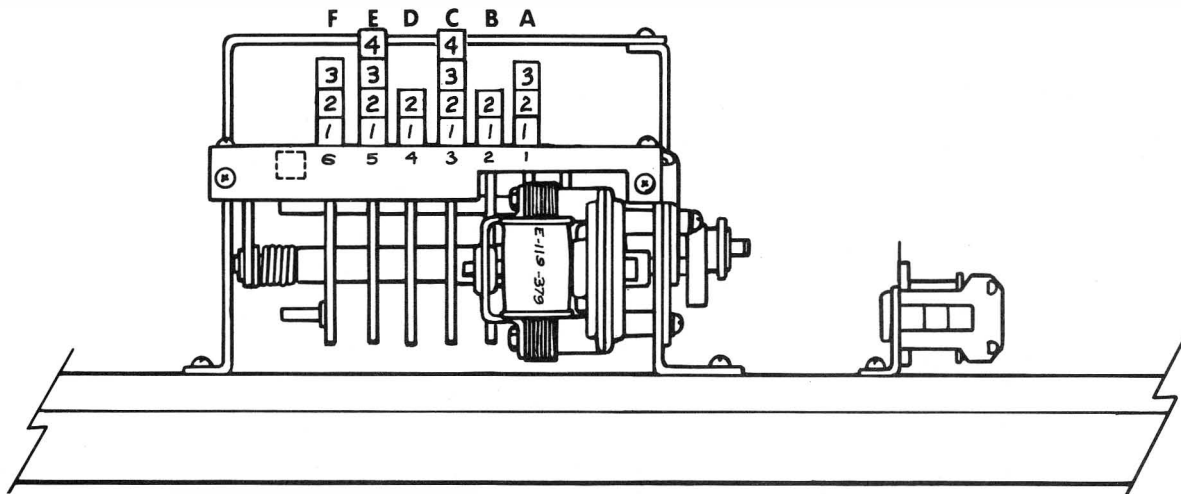

Switch/Coil	Part No.	Location on Diagram	Wire No.	Wire Color	Function
MOTOR	E-119-379	A-9	70 80-2	Orange Black	Energized when game is coined or when credits are on register thru start relay switches.
A1 N.O. Cam 1	ASW-C1-27	D-8	80-2 30	Black Yellow	Carry over switch.
A2 N.C. Cam 1	ASW-C2-15	F-14	85-1 30	Black-White Yellow	Open circuit to 1-2-3 & 4-5-6 Search Discs.
A3 N.C. Cam 1	ASW-C2-2	A-8	54 52	White-Green White-Blue	Open circuit to timer index cam coil.
B1 N.O. Cam 2 (C.W.O.)	ASW-C1-27	F-38	93-9 21-3	Gray-Yellow Blue-Red	Completes circuit to random motor.
B2 N.C. Cam 2 (O.W.O.)	ASW-C2-15	E-39	15-9 21-3	Red-White Blue-Red	Open circuit to B-3 Lockout trip.
C1 N.O. Cam 3	ASW-C1-27	E-25	98-1 30	Gray-Black Yellow	Completes circuit to timer unit reset coil.
C2 N.O. Cam 3	ASW-C1-8	E-21	30 83-3	Yellow Black-Yellow	Completes circuit to 11 trip bank motor.
C3 N.O. Cam 3	ASW-C1-8	E-23	30 85-3	Yellow Black-White	Completes circuit to selection unit & replay counters 1, 2, 3 reset coils.
C4 N.O. Cam 3	ASW-C1-8	E-22	30 90-1	Yellow Gray	Completes circuit to 18 trip bank motor.
D1 N.O. Cam 4 (O.W.O.)	ASW-C1-27	E-5	27-4 63-4	Blue-Orange Brown-Yellow	Completes circuit to the start relay if credits are on register thru replay button.
D2 N.C. Cam 4 (C.W.O.)	ASW-C1-15	F-28	21-3 74-4	Blue-Red Orange-Green	Opens a circuit to sel B-3 trip & flash control relay.
E1 S.P.D.T. Cam 5	ASW-C3-8	B-8	80-2 58 54	Black White-Black White-Green	Completes a circuit to shutter motor & opens a circuit to timer cam index coil.
E2 N.C. Cam #5 (C.W.O.)	ASW-C2-3	E-10	81-4 56-3	Black-Red White-Brown	Completes a circuit to lifter start relay coil.
E3 N.C. Cam #5 (C.W.O.)	ASW-C2-2	F-9	36-3 38-2	Yellow-Brown Yellow-Black	Completes a circuit to shutter motor if tilted.
E4 N.C. Cam #5	ASW-C2-2	C-9	27-2 38-2	Blue-Orange Yellow-Black	Completes a circuit to shutter motor thru timer unit disc.
F1 N.O. Cam #6	ASW-C10-5	E-22	90-1 30	Gray Yellow	Completes a circuit to 18 trip bank motor.
F2 N.O. Cam #6	ASW-C10-1	F-23	78-4 30	Orange-Black Yellow	Completes a circuit to 4-5-6 replay counters reset coil.
F3 N.O. Cam #6	ASW-C10-1	E-21	83-3 30	Black-Yellow Yellow	Completes a circuit to 11 trip bank motor.

PANEL SHUTTER ASSEMBLY

Switch/Coil	Part No.	Location on Diagram	Wire No.	Wire Color	Function
Lifter Start Relay	G-32-2500	A-11	70 40-3	Orange Green	Energized via shutter motor cam #5 Switch.
A. N. O.	ASW-R1-1	C-10	54-3 40-3	White-Green Green	Completes circuit when start relay is energized
B. N. C.	ASW-R2-5	D-39	20-9 15-9	Blue Red-White	Opens circuit to ball lifter cam #1 Switch
C. N. C.	ASW-R2-5	E-12	21-3 60-3	Blue-Red Brown	Opens circuit to ball lifter switch breaking circuit to ball lifter motor
D. N. C.	ASW-R2-5	D-9	57-2 38-2	White-Orange Yellow-Black	Opens circuit to shutter motor.
Ball Lifter Motor	E-119-339	A-12	70 74-3	Orange Orange-Green	Energizes ball lifter motor
Cam 1 A. N. O.	ASW-C1-6	E-12	30 61-3	Yellow Brown-Red	Completes circuit to 5th ball trough sw., ball lifter motor circuit
Cam 1 B. N. C.	ASW-C2-15	B-9	27-2 80-2	Blue-Orange Black	Opens circuit to shutter motor
Cam 1 C. N. C.	ASW-C2-2	C-39	25-9 20-9	Blue-White Blue	Opens circuit to pads on timer disc
Cam 2 A. N. O.	ASW-C1-53	D-10	48-6 63-2	Green-Black Brown-Yellow	Completes circuit to replay cams index sw., timer step-up coil circuit

STEPPING UNITS SW. & COIL CHART

Switch/Coil	Part No.	Location on Diagram	Wire No.	Wire Color	Function
Toggle Sw. N. O.	E-108-57	E-1	30-16 80-16	Yellow Black	Circuit to 10 Amp Fuse & transformer (See Schematic)
Coin Sw. N. O.	AS-2744	D-6	53-8 51-2 91-3	White-Yellow White-Red Grey-Red	Completes circuit to multi-play (91-3), then directs circuit to 53-8 & 13-7 start relay.
Coin Lockout Coil	AS-2717-14	A-6	70 45-3	Orange Green-White	De-energized via replay register "O" Switch.
Replay Button Sw. N. O.	ASW-A1-37	D-5	95-3 90-2	Grey-White Grey	Directs circuit to start relay.
REPLAY REGISTER					
Step Up Coil	A-27-1400	A-13	70 78-3	Orange Orange-Black	Energized thru control unit cam #5 also thru replay key switch.
Reset Coil	A-26-1100	A-5	70 50	Orange White	Energized thru S16 Pulse control unit cam #2.
Transfer "O" Switch S. P. D. T.	ASW-U3-6	E-5	56-2 63-4 51-2	White-Brown Brown-Yellow White-Red	Directs circuit to start relay via the 'R' button switch when credits on register.
"O" Switch N. O.	ASW-U1-6	C-5	95-3 10-1	Grey-White Red	Completes a circuit to the start replay when credits are on register.

STEPPING UNITS SW. & COIL CHART

Switch/Coil	Part No.	Location on Diagram	Wire No.	Wire Color	Function
'C' Button (Collect) A.	ASW-A11-4 Bottom	C-24	54-2 18-2	White-Green Red-Black	Can be pushed in after 4th ball on winner. Energizes 1-2-3 search wiper lock coil - must be pushed in before R or D button.
'C' Button (Collect) B.	ASW-A11-4	D-25	21-3 52-3	Blue-Red White-Blue	Energizes Timer Reset Coil
Select Button	ASW-A1-22	D-40	13-8 25-5	Red-Yellow Blue-White	Can be pushed in after shooting 2nd ball if select before 3 trips. Also can be pushed in before shooting 4th ball if select before -4 trips to select spot on cards.
'R' Button Regular Win S.P.D.T.	ASW-A21-22	D-26	23-5 95 15J	Blue-Yellow Gray-White Red-White	Can be pushed in after pushing in 'C' button (winner search) (after 4th or 5th ball) to put a regular win on register.
'D' Button (Double or Nothing)	ASW-A1-22	C-26	65-8 15J	Brown-White Red-White	Can be pushed in after pushing 'C' button (winner search) (after 4th or 5th ball) to determine double or nothing win on register.
Replay Button (Red) Sw. N.O.	ASW-A1-37	D-5	90-2 95-3	Gray Gray-White	When there are credits on register replay button can be pressed to set up a new game.
Manual Lift Button Below Plunger A. N.O.	ASW-A1-26	D-12	60-3 61-3	Brown Brown-Red	Completes a circuit to ball lift
N.C. B.	ASW-A2-9	D-11	56-3 30	White-Brown Yellow	Opens a circuit to lifter start relay.
FRONT CABINET UNITS					
5th Ball Through Sw. N.O.		D-11	61-3 74-3	Brown-Red Orange-Green	Completes a circuit to ball lifter motor.
3rd Ball Through Sw. N.C.		C-39	25-9 10-9	Blue-White Red	Opens a circuit to B-3 Lockout trip re.
2nd Ball Through Sw. N.C.		C-39	25-9 80-5	Blue-White Black	Opens a circuit to B-4 Lockout trip re.
Ball Runway Sw. N.O.	ASW-A1-30	C-10	30 40-3	Yellow Green	Energizes lifter start re & hold in thru ball gate sw.
Ball Gate Sw. N.C.	ASW-A2-5	D-10	56-3 54-3	White-Brown White-Green	Drops lifter start relay when ball enters the playfield.
REPLAY KEY SWITCH					
Replay Key Meter	E-130-10	A-14	70 43-3	Orange Green-Yellow	Energized in series with replay register step up thru turning the key (single step).
1. N.C.	ASW-B-1	A-5	98-3 48-2	Gray-Black Green-Black	Opens circuit to start relay coil.
2. N.O.	ASW-B-2	C-13	93-2 80-3	Gray-Yellow Black	Completes circuit to key meter & register step up.
3. N.O.	ASW-B-2	B-13	78-3 43-3	Orange-Black Green-Yellow	Completes a circuit to key meter.
4. N.O.	ASW-B-2	B-11	21-3 65-1	Blue-Red Brown-White	Completes a circuit to tilt trip relay.
5. N.O.	ASW-B-2	C-4	30 15-7	Yellow Red-White	Completes a circuit to anti cheat relay.
6. S.P.D.T.	ASW-C3-6	B-13	14 78-3 80-3	Red-Green Orange-Black Black	Completes circuit to key meter & register step up.

MOTOR PARTS GUIDE

CONTROL UNIT MOTOR E-119-452

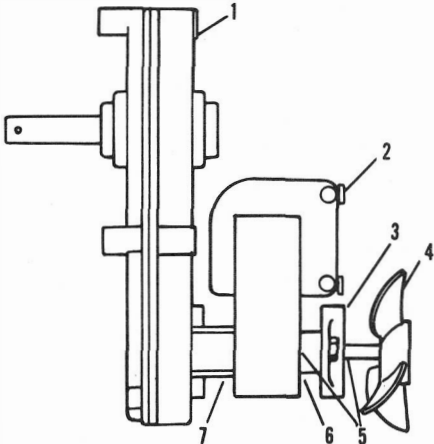

Index No.	Part No.	Description	No. Req.
1	GC3-4017-1	Transmission Unit . . .	1
2	AS3-4017-1	Stator Unit	1
3	ABB-1010-02	Bearing & Brkt. Assy. . .	1
4	S-1011-00	Fan	1
Note: Order Index No.'s 5 - 7 as a unit			
5	AR3-4017-1	Rotor & Shaft Unit . . .	1
6	W-1014-03	Rotor Shaft Washer . . .	1
7	W-1017-20	Rotor Shaft Washer . . .	1
	W-1014-15	Rotor Shaft Washer . . .	1
	W-1014-25	Rotor Shaft Washer . . .	1

TRIP BANK RELAY MOTOR E-119-464

Index No.	Part No.	Description	No. Req.
1	GC2-2543-1	Transmission Unit	1
2	AS2-2543-1	Stator Unit	1
3	ABB-1010-01	Bearing & Brkt. Assy. . . .	1
Note: Order Index No.'s 4 - 6 as a unit			
4	AR2-2543-1	Rotor & Shaft Unit	1
5	W-1015-03	Rotor Shaft Washer	1
6	W-1014-03	Rotor Shaft Washer	1
	W-1014-09	Rotor Shaft Washer	3

PANEL SHUTTER MOTOR E-119-379

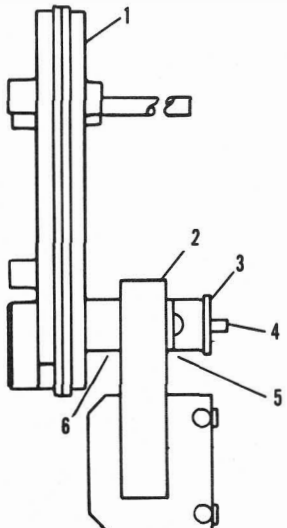

Index No.	Part No.	Description	No. Req.
1	GC2-1725-1	Transmission Unit	1
2	AS2-1725-1	Stator Unit	1
3	ABB-2010-01	Bearing & Brkt. Assy. . . .	1
Note: Order Index No.'s 4 - 6 as a unit			
4	AR2-1725-1	Rotor & Shaft Unit	1
5	W-1015-03	Rotor Shaft Washer	1
6	J-1011-60	Shaft Shim Spring	1

BALL LIFTER MOTOR E-119-339

Index No.	Part No.	Description	No. Req.
1	GC2-1743-1	Transmission Unit	1
2	AS2-1743-1	Stator Unit	1
3	ABB-1010-1	Bearing & Brkt. Assy. . . .	1
Note: Order Index No.'s 4 - 6 as a unit			
4	AR2-1743-1	Rotor & Shaft Unit	1
5	W-1015-03	Rotor Shaft Washer	1
6	J-1011-60	Shaft Shim Spring	1

ALWAYS GIVE MODEL AND PART NO. WHEN ORDERING SERVICE PARTS

PARTS GUIDE

FRONT CABINET ASSEMBLY

Part No.	Description
CA-1197-9	Front Cabinet
M-281-58	Lock (Replay Switch)
AS-982-673	Replay Key Sw. Assy. (top)
AS-982-671	Replay Key Sw. Assy. (bottom)
AS-982-1103	R. D & Select Button Sw. Bracket Assembly
AS-982-933	C Button Sw. & Bracket Assembly
E-108-57	Game Off-On Switch
A-2618	Legs
M-106-1	Leg Bolt (8)
M-163-4	Leg Adjuster
N3-816-1110	Leg Adj. Nut
A-2719-4	Coin Slide Assy.
A-2790-59	Cash Box Assy.
P-3089-55	Cash Box Cover
P-921-68	Chrome Glass Molding - Left
P-921-69	Chrome Glass Molding - Rt.
G-213	Top Glass
CA-439-27	Ball Return Panel
P-5940-18	Front Door Trim Right
P-5940-33	Front Door Trim Left
P-5940-40	Front Door Trim Top
P-5940-41	Front Door Trim Bottom
M-168-15	Ball Set (5)
AS-187-17	Ball Shooter Assembly
A-100-7	Knob & Shooter Rod
SP-243	Front Compression Spring
AS-1835	Front Shooter Guide Unit
SP-200-24	Rear Compression Spring
P-2879	Spring Cap (rear)
P-2891-8	Retaining Ring
R-108-3	Shooter Tip

BACK CABINET ASSEMBLY

Part No.	Description
G-394-9	Blue Chip Back Glass
CA-713-93	Back Cabinet
M-475-1	Nut (2 req'd) Glass Molding Retainer
CA-1173-4	Wood Side Molding - Right
CA-1173-5	Wood Side Molding - Left
P-2830	Lock Bracket (2)
M-281-31	2 Lock Set
P-2831	Lock Retainer (2)
E-126-63	Cord Set
A-1511-34	Back Door Hinge (top)
A-1511-33	Back Door Hinge (bottom)
	Front Molding
AS-1305-62	Front Molding Assembly (complete)
A-1272-20	Button & Pin Assy. (D)
A-1272-25	Button & Pin Assy. (C)
A-1272-59	Button & Pin Assy. (R)
A-1272-60	Button & Pin Assy. (sel.)
P-2210-	Coin Drop Plate (As Req'd.)

FRONT DOOR ASSEMBLY

AS-2041-83	Front Door Assembly (complete)
M-281-54	Lock
A-254-117	Hinge Assembly
	Slug Rejector (specify coin denomination)
AS-2517-14	Coin Lockout Assembly
AS-2517-12	Coin Deflector (cash box split)
E-108-92	Coin Switch
P-6431 Series	Coin Guide Spacer (specify coin denomination)
P-6694 Series	Coin Guide (Specify coin denomination)
A-1729-16	Push Button Assy. (replay)
P-800-2	Washer
P-2891-7	Retaining Ring
ASW-A1-37	Replay Switch
ASW-A1-27	Tilt Switch

BACK DOOR ASSEMBLY

CA-1120-45	Back Door (painted)
P-2335-9	Hinge (2)
M-281-24	2 Lock Set
P-758-16	Lock Cam (bottom)
P-758-17	Lock Cam (top)
R-206-1	Rubber Bumper (outside door) - 2 Req'd

NOTE: ALL PLASTIC PARTS can easily be repaired by using 3M Scotch-Grip Industrial Adhesive 4475.

PLAYFIELD PANEL

AS-2042-163	Playfield Panel - Complete W/All Units Installed
CA-638-95	Panel
CA-1100-9	Arch Bottom
CA-1103	Arch Guide Strip
CA-1104	Arch Top
C-326-9	Light Shield Post (White)
E-125-2	Light Bulb #47 (8 Req'd)
M-170	Rebound Spring Unit (8 Req'd)
SP-112-1	Short Panel Spring (4 Req'd)
SP-112	Long Panel Spring (8 Req'd)
S-196	Playfield Pin (Springs - 15 Req'd)
S-1071-84	Pinning Rods (29)
C-119-21	Red Bumper Post (4)
R-243-2	Red Bumper Rubber (4)
C-119-23	Yellow Bumper Post (30)
R-243	Bumper Rubber (26)
R-135	Double Bumper Rubber (2)
R-115-4	Top Rebound Rubber
C-153	Red Plastic Ball Lift Cover

[NOTE: FOR YOUR CONVENIENCE EXTRA REPLACEMENT SCORE CARDS]

DEPOSIT COINS OR PLAY REPLAYS

BY PRESSING RED BUTTON
TO LIGHT 1 TO 6 CARDS
ONE CARD GUARANTEED
for each coin deposited

CORNERS PANELS
AND SUPER LINES
LIGHT ON MYSTERY BASIS
AS CARDS LIGHT

DEPOSIT ADDITIONAL COINS
FOR
SELECT-A-SPOT FEATURE

**3 IN LINE scores as 4 IN LINE
4 IN LINE scores as 5 IN LINE
when lined up in a
LIT SUPER LINE**

BC-1

**AFTER SHOOTING 5 BALLS
FIRST PRESS "C" BUTTON
WHEN**

DOUBLE OR NOTHING

**LIGHTS FLASH
PRESS "D" BUTTON
TO TRY FOR DOUBLE OR NOTHING**
in any desired winning card or cards

OR

**PRESS "R" BUTTON
TO COLLECT REGULAR SCORE**
in any desired winning card or cards

BC-2

ONLY HIGHEST SCORE PER CARD REGISTERS—REGULAR OR DOUBLE.

SCORE VOID IF GAME IS TILTED.

1st CARD	2nd CARD	3rd CARD	4th CARD	5th CARD	6th CARD
3 IN LINE ... 4	3 IN LINE ... 4	3 IN LINE ... 4	3 IN LINE ... 4	3 IN LINE ... 4	3 IN LINE ... 4
4 IN LINE ... 20	4 IN LINE ... 20	4 IN LINE ... 20	4 IN LINE ... 24	4 IN LINE ... 36	4 IN LINE ... 40
5 IN LINE ... 100	5 IN LINE ... 100	5 IN LINE ... 120	5 IN LINE ... 140	5 IN LINE ... 240	5 IN LINE ... 240

BC-3B

A GAME OF SKILL FOR AMUSEMENT ONLY. NO GAMBLING PERMITTED.

ONLY HIGHEST SCORE PER CARD REGISTERS—REGULAR OR DOUBLE.

SCORE VOID IF GAME IS TILTED.

1st CARD	2nd CARD	3rd CARD	4th CARD	5th CARD	6th CARD
3 IN LINE ... 4	3 IN LINE ... 4	3 IN LINE ... 4	3 IN LINE ... 4	3 IN LINE ... 4	3 IN LINE ... 4
4 IN LINE ... 16	4 IN LINE ... 20	4 IN LINE ... 20	4 IN LINE ... 24	4 IN LINE ... 36	4 IN LINE ... 44
5 IN LINE ... 100	5 IN LINE ... 100	5 IN LINE ... 120	5 IN LINE ... 140	5 IN LINE ... 240	5 IN LINE ... 300

BC-3A

A GAME OF SKILL FOR AMUSEMENT ONLY. NO GAMBLING PERMITTED.

ONLY HIGHEST SCORE PER CARD REGISTERS—REGULAR OR DOUBLE.

SCORE VOID IF GAME IS TILTED.

1st CARD	2nd CARD	3rd CARD	4th CARD	5th CARD	6th CARD
3 IN LINE ... 4	3 IN LINE ... 4	3 IN LINE ... 4	3 IN LINE ... 4	3 IN LINE ... 4	3 IN LINE ... 4
4 IN LINE ... 20	4 IN LINE ... 20	4 IN LINE ... 20	4 IN LINE ... 24	4 IN LINE ... 36	4 IN LINE ... 44
5 IN LINE ... 100	5 IN LINE ... 100	5 IN LINE ... 120	5 IN LINE ... 140	5 IN LINE ... 240	5 IN LINE ... 300

BC-3

A GAME OF SKILL FOR AMUSEMENT ONLY. NO GAMBLING PERMITTED.