

Bally
CONTINENTAL

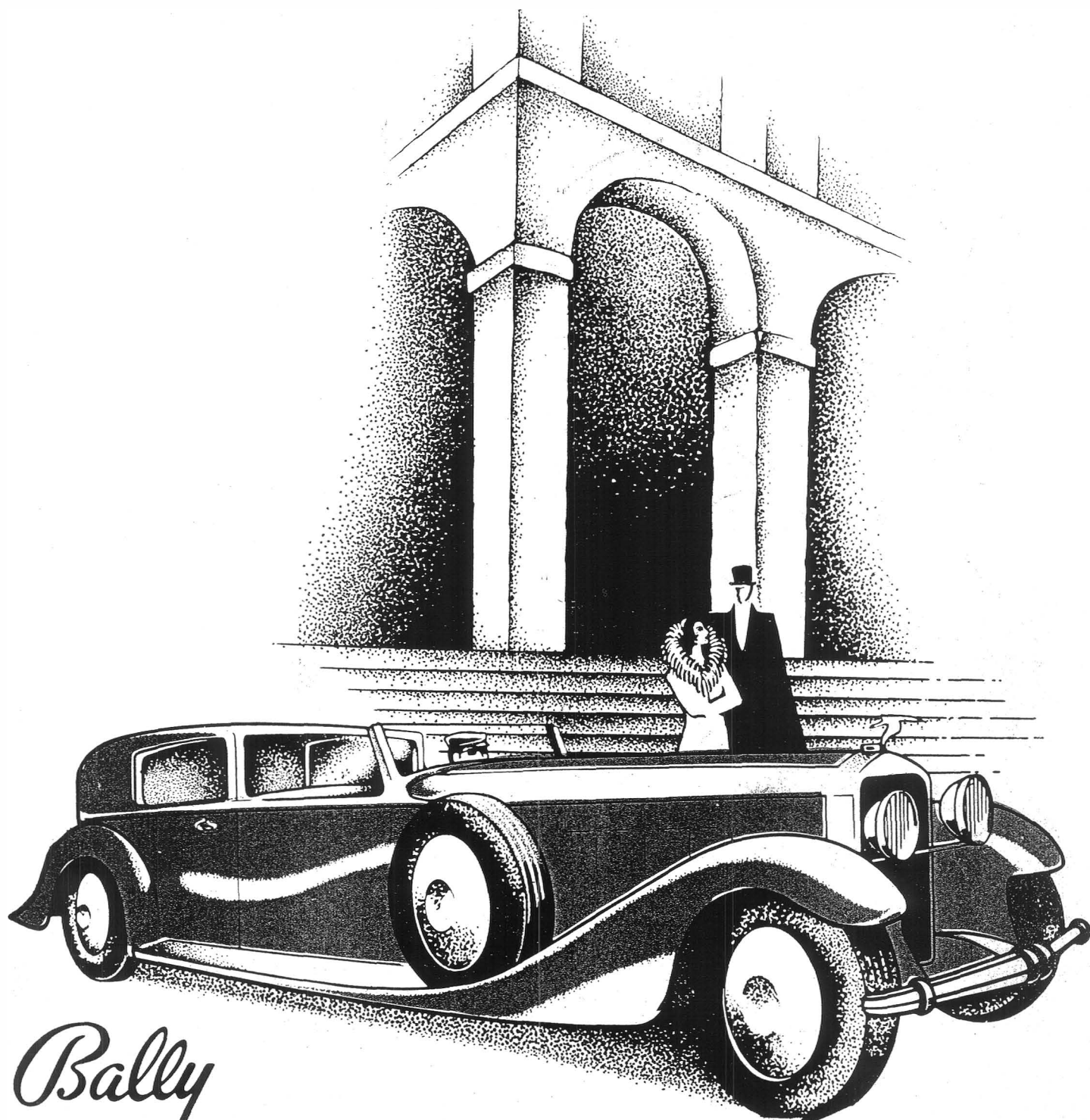

Bally

Manufacturing Corporation

© BALLY MFG. CORP. 1980
ALL RIGHTS RESERVED

CONTENTS

	PAGE
I. INTRODUCTION	2
II. INSTALLATION	6
III. GAME OPERATION	
A. GENERAL	9
B. REMOTE CONTROL	10
IV. BOOKKEEPING FUNCTIONS – KEYBOARD DISPLAY UNIT (KDU)	
A. ELECTRONIC	11
B. MECHANICAL	12
V. GAME ADJUSTMENTS	
A. PLAYFIELD	13
B. BACK BOX	13
C. FRONT DOOR	14
VI. ROUTINE MAINTENANCE	
A. DIAGNOSTIC TESTS	15
B. KEYBOARD OPERATION	15
C. TEST PROCEDURE	15
D. SERVICE HINTS	20
VII. UNIT ASSEMBLY LAYOUT	
A. PLAYFIELD	21
B. FRONT CABINET	23
C. BACK BOX	24
D. LAMP DRIVER MODULE – (LDA)	25
E. LAMP DRIVER MODULE – (LDB)	25
F. MICROPROCESSOR MODULE (MPU)	26
G. PARTS LIST	27
VIII. SCHEMATIC DIAGRAMS	28

I. INTRODUCTION

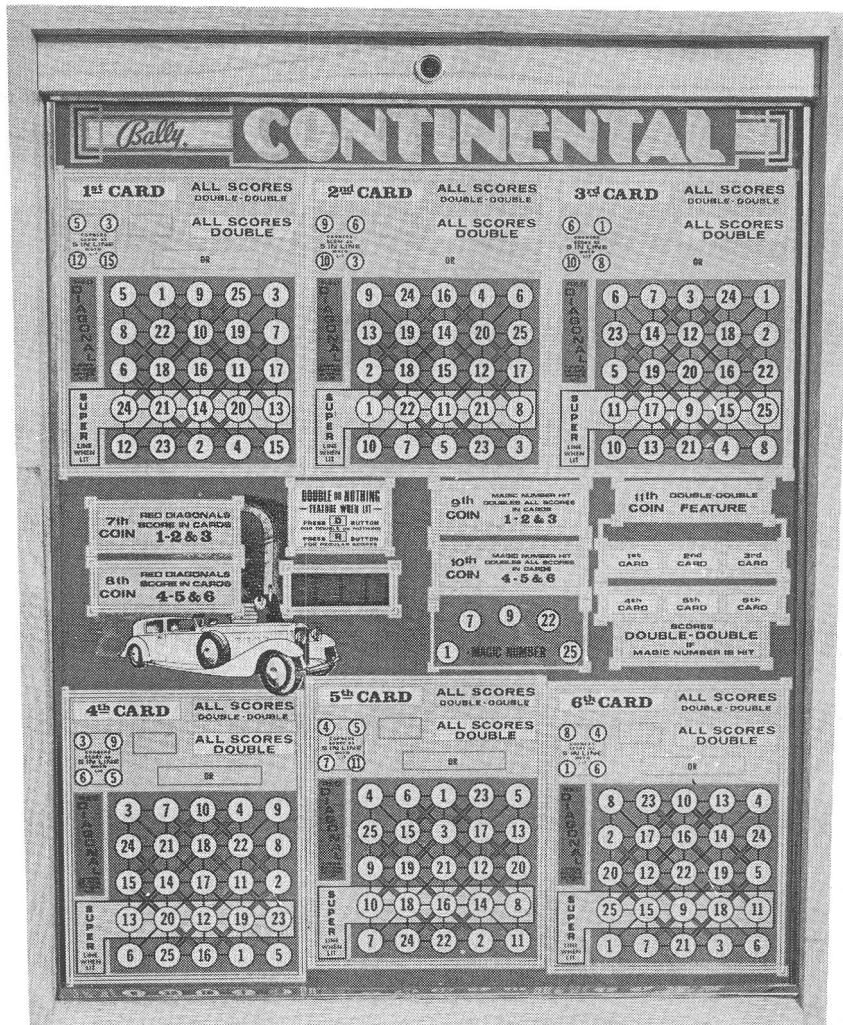

The Continental is the first bingo game from Bally to fully employ digital techniques and self-monitoring microprocessor control. Based on the well received six card games offered previously, and self-diagnostic features which provide business information and quicker, easier maintenance.

As in other 11 coin games, the initial six coins put all cards in play, the seventh and eighth coins make diagonal winners possible.

MAGIC NUMBERS

After the ninth coin is inserted and the first ball shot, the magic numbers flash and one or two remain lit on a random basis. If a player gets a ball into a hole corresponding to a lit magic number, all scores in cards 1-2-3 are doubled, the tenth coin extends this feature for cards 4-5-6.

DOUBLE DOUBLE SCORES

When the eleventh coin or credit (replay) is played, upon shooting the first ball, in addition to magic numbers, double-double selection lights are activated under two cards, chosen at random.

Winners on these cards receive double-double scores when a ball is in the hole corresponding with a lit magic number. With subsequent use of the Double or Nothing feature button, even double-double-double scores become possible. Other favorite scoring highlights continued in the Continental are: (when lit) corners score as 5-in-line, Superlines in which 3-in-line scores as 4-in-line and 4-in-line as 5-in-line.

SCORE MULTIPLIER

Winning scores may be multiplied up to X10 when additional credits are played after the first eleven. Each additional eleven credits played increases the multiplier to the next whole number. For example, playing 22 credits makes possible a X2 score and when the maximum 110 credits are played, the X10 multiplier circuits are activated. This feature may be turned off or limited to a X6 factor (see section V).

REMOTE CONTROL UNIT

This device can be used to register any number of credits or reset the game to zero from a remote location.

Schematic diagrams are in the final section of the manual. Appearance items, cabinet parts and mechanical assemblies are listed at the end of Section VII.

BLOCK DIAGRAM-ELECTRONIC BINGO GAME
1195E-1

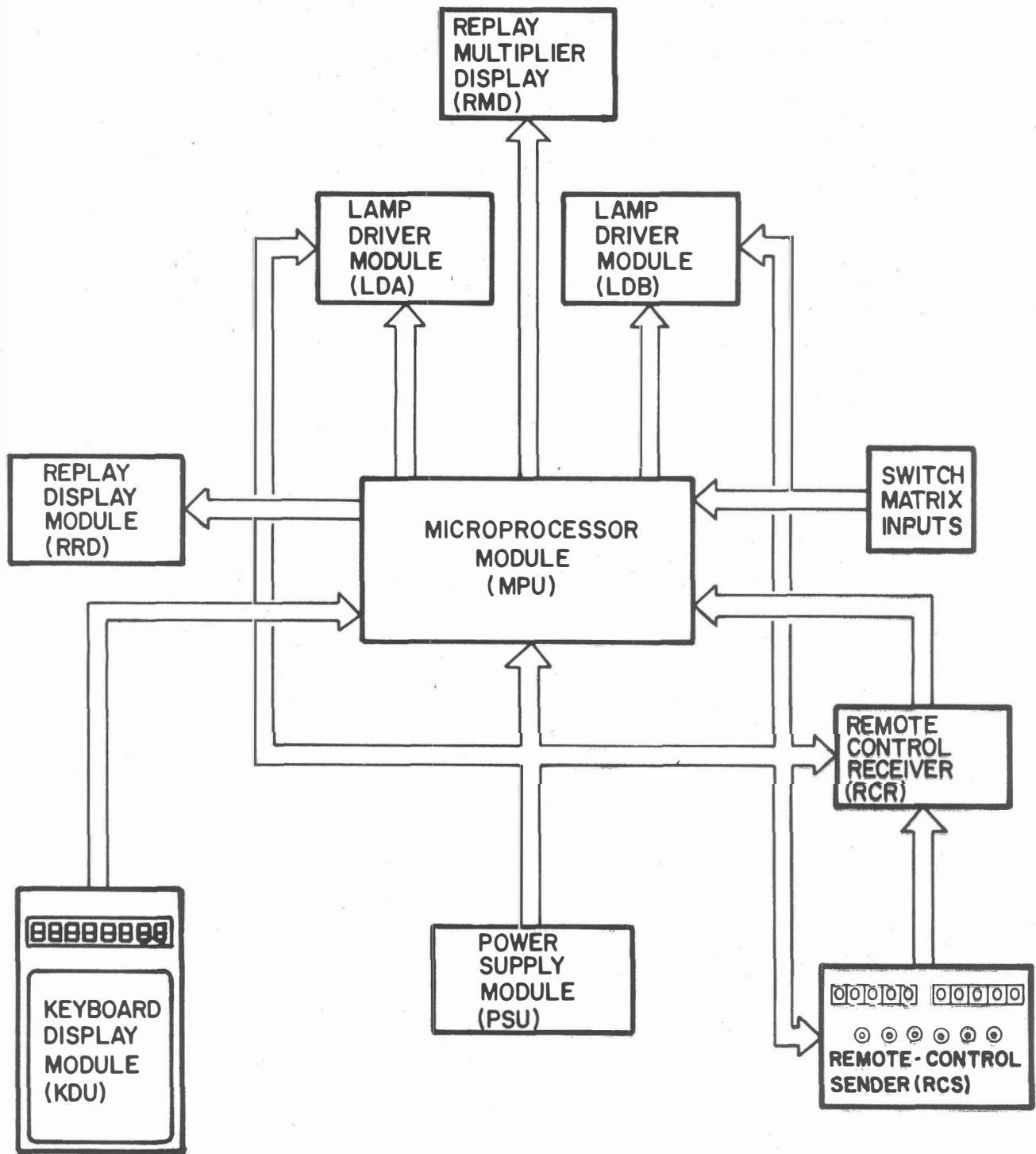

CIRCUIT FUNCTIONS

The block diagram shows the signal flow between the component modules of the 1195E-1 bingo game. The points where arrows enter the Microprocessor Module lead to Input Ports — the communication link between the microprocessor and data from the Keyboard Display Module, Remote Control Sender and the Switch Matrix which acts as the “eyes” of the microprocessor. Arrows emerging from the MPU board are from Output Ports, by which instructions and data are transferred from the microprocessor or memory components to output devices such as the lamp driver modules, displays, solenoids and motors.

The microprocessor is a *programmed* integrated circuit which performs a wide variety of electronic tasks. It is connected to other integrated circuits on the MPU module thru the data bus and address bus by which data and instructions pass back and forth. A control bus links the components to synchronize system functions.

Specific sequential instructions to be carried out by the microprocessor are stored in the *program* memory. When the “power up” state is reached, the first instruction will be obtained from this memory via the data bus. After executing this instruction the microprocessor will signal for the second, etc.

The microprocessor tests the MPU module first, then makes the game ready for play. A large part of the MPU activity consists of monitoring the memory record of the switches on the playfield and in the cabinet, other tasks include servicing display updates, motors, solenoids and scanning lamps and momentary switches. Several additional memory IC's store more data and instructions for the microprocessor.

II. INSTALLATION

A. Assembly (See Figure 1)

1. Using flat washers under bolt heads, bolt legs to cabinet.
2. Unlock and remove back glass from back box, loosen screws on light panel retaining brack
3. Position back box on cabinet, lift and tilt light panel forward to rest on cabinet for access main cable and printed circuit board.
4. Bolt back box to cabinet.
5. Gently feed cable connectors and ground braids from cabinet through port in back box.
6. Bolt ground braids to stud on power supply chassis.
7. Carefully and fully insert (4) back box cable connectors into cabinet connectors.
8. Insert power supply cable connector completely into receptacle on chassis.

B. Inspection

After assembly, a visual inspection of the game must be made to correct loose connections or proper switch adjustments that may occur due to rough handling during shipment.

Caution: Do not plug in line cord before completing the following steps:

1. Check that all cable connectors are completely seated on printed circuit assemblies.
2. Check that all cables are clear of moving parts.
3. Check for any wires that may have become disconnected.
4. Check switches for loose solder or other foreign material that may be shorting contacts.
5. Check that fuses are firmly seated and making good contact.
6. Check that integrated circuits mounted on P.C. sockets are firmly seated.

(Continued)

INSTALLATION

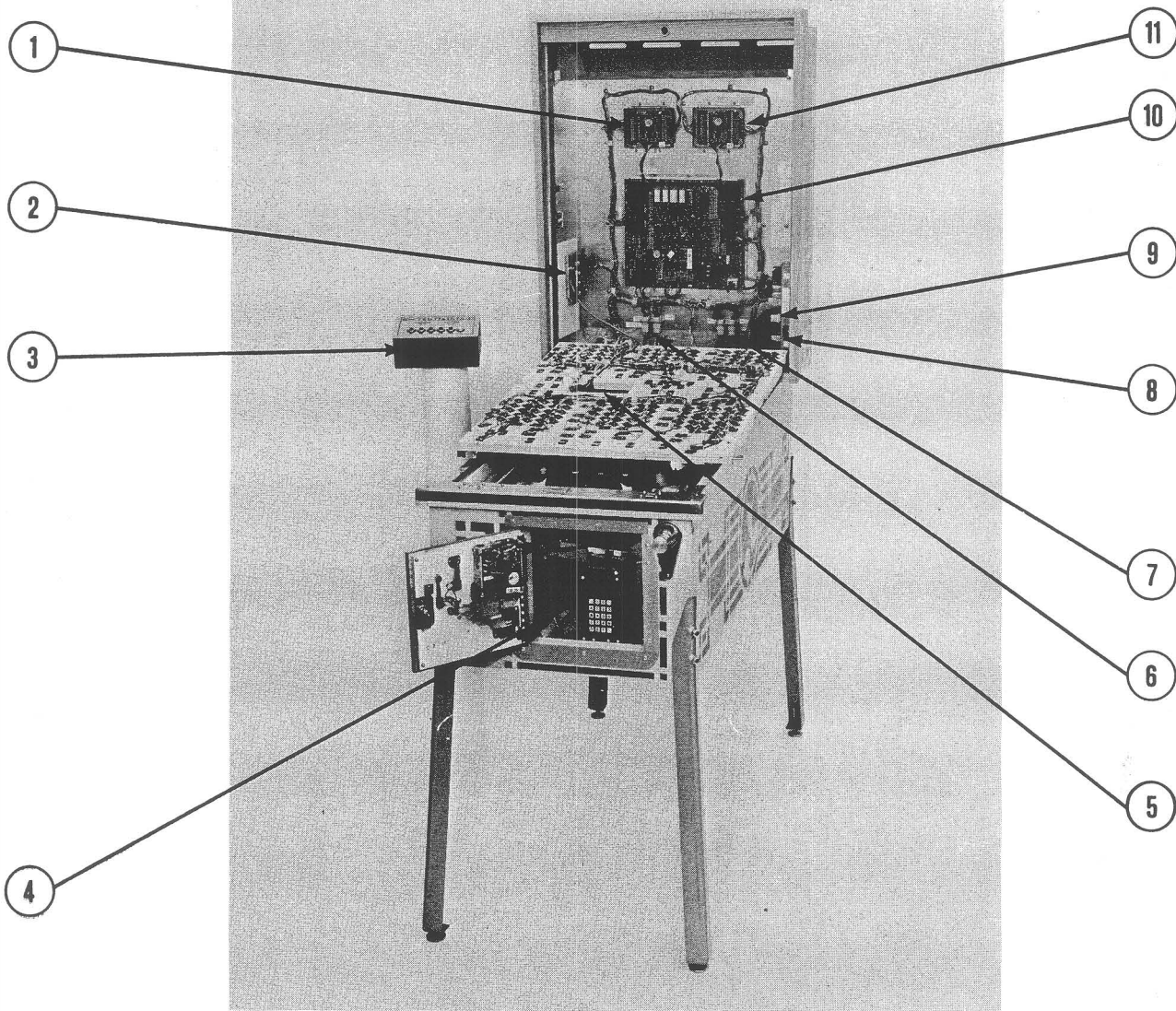

FIGURE 1 MODEL 1195E-1 BINGO GAME

- | | |
|----------------------------------|-------------------------------|
| 1. Lamp Driver Unit (LDA) | 7. Front Cabinet Plugs |
| 2. Remote Control Receiver (RCR) | 8. Power Supply Plug |
| 3. Remote Control Sender (RCS) | 9. Line Code Plug |
| 4. Keyboard Display Unit (KDU) | 10. Microprocessor Unit (MPU) |
| 5. Replay Display (RRD) | 11. Lamp Driver Unit (LDB) |
| 6. Panel Plugs | |

(Continued)

INSTALLATION

7. Check adjustment of the (3) tilt switches (normally open).
 - a. Slam switch on front door.
 - b. Slam switch on bottom right side of cabinet.
 - c. Plumb bob tilt switch on left side of cabinet.

NOTE: Game should be placed on desired location and leg levelers adjusted before setting plumb bob tilt switch.

8. Check power supply for any foreign material shorting across components.
9. Check location line voltage and adjust power supply to suitable value.

TO ADJUST POWER SUPPLY:

Insert correct "line code" plug into receptacle on power supply chassis to match power input available, as shown in Figure 1. Games are normally supplied with two plugs, one wired for 120 VAC and the other for 220 VAC operation. Figure 2 shows wiring of "line code" plugs.

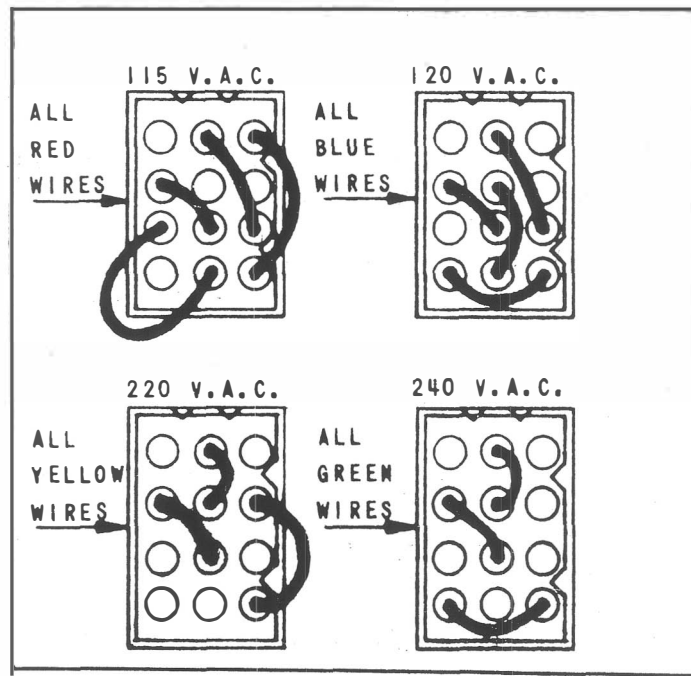

FIGURE 2

III. GAME OPERATION

A. GENERAL

Plug in line cord. Move power On-Off master switch to "On" position. The general illumination panel and back glass lamps will light. After several seconds the electronic replay display will light. The display will show all zeros. If there is a value other than zero on the display it will change to zero after a few seconds. The game is ready for play.

One card or feature is granted for each coin or credit that is played. The credits are reduced by one each time the credit button is depressed until the credits are reduced to zero or the maximum credits per game is reached.

Upon buying the first card or feature (either by coin or credit) any balls remaining on the playfield from the previous game will be dumped. When all balls have reached the ball trough the first ball will lift to the ball shooter. The game is now ready to play. In the case where a ball was left at the ball shooter, from the previous game, if the remaining four balls are allowed to settle to the ball trough, the ball at the shooter will be the first ball of the game.

Shooting the ball initiates game play. Attaining three, four or five lights in a row or at corners when the feature is lit, awards credits according to the replay schedule.

Closing any of the tilt switches, results in ending the game. The hole lights and all feature lights go out and the tilt light turns on. Any winning combinations attained but not credited are void.

The multiplication factor for a game being played is shown on the Score Multiplier Display, located at the lower left corner of the playfield.

When scores are increased up to X10 using the Score Multiplier, the number of credits awarded may exceed 9999. If this should occur, the replay display will return to zero and resume counting. At the same time the "L" in "CONTINENTAL" lites up on the back glass to indicate overflow. Maximum capacity of the credit (replay) memory is 19,999, after which the game tilts out.

(Continued)

GAME OPERATION

B. REMOTE CONTROL

From a remote location, the game may be reset to zero or credits may be awarded in amounts of 1, 10, 25, 50 or 100 by pressing the proper button on the Remote Control Unit. When the reset button is actuated, the game cannot be operated until all credits have run off and the Replay Display returns to zero.

The unit has two meters, one records credits registered on the game by remote control (telephone in) and the other meter shows credits removed by using the reset button (telephone out).



AS-3062 REMOTE CONTROL SENDER (RCS)

IV. BOOKKEEPING FUNCTIONS—KEYBOARD DISPLAY UNIT (KDU)

A. ELECTRONIC

A large part of the design effort realized in the game is devoted to help the operator perform accounting tasks.

Bookkeeping functions are obtained and displayed by means of a hand held Keyboard Display Unit (AS-3051) supplied with the game. For use, connect the attached extension cable to terminal J23-B, which is located just inside and slightly left of the cabinet door.

There are two states of operation for the Bally Electronic Bingo game. One is the normal (play) mode and the other is a diagnostic mode obtained by pressing the KEYBD/CLR button on the Keyboard Display Unit (KDU). When not in use, the KDU may be left connected and stored in the front cabinet.

To return game to the normal (play) mode, depress the "Game" button.

Caution: Position the KDU and cable carefully in the cabinet to avoid moving parts and terminals.

To view a particular function, switch the game to the diagnostic mode as described and enter the code unique to that function on the keypad. The value contained in the memory reserved for the function will then be displayed.

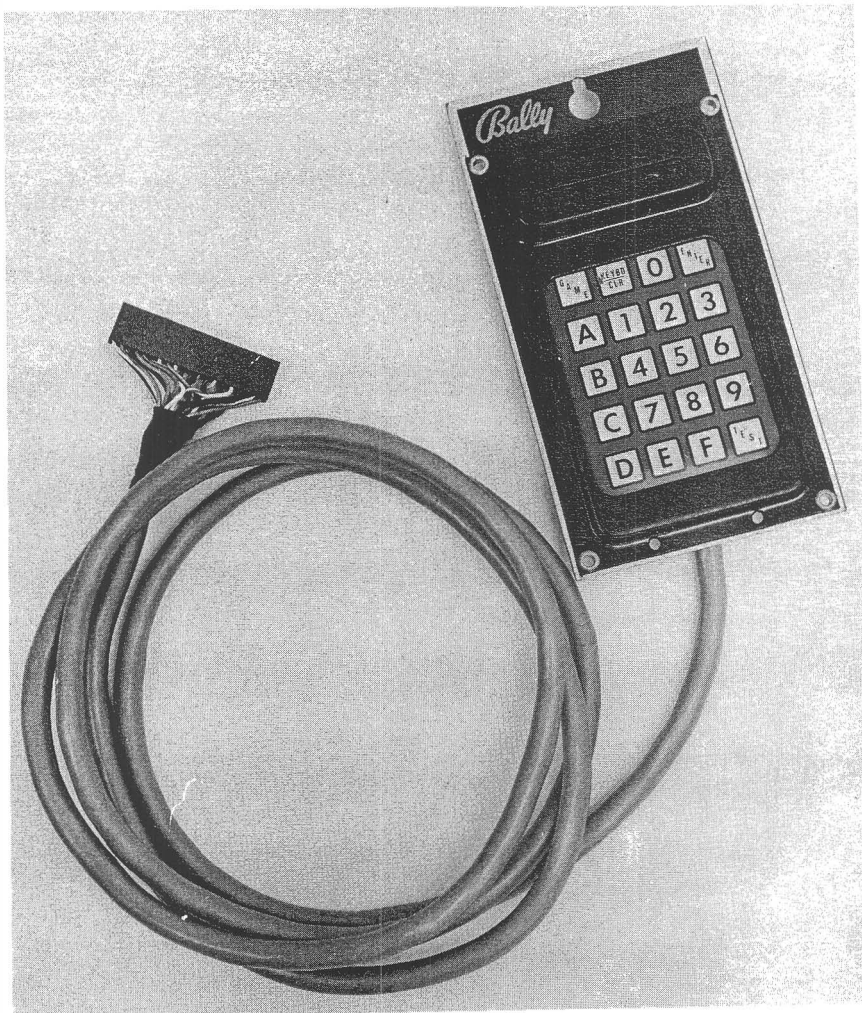

AS-3051 KEYBOARD DISPLAY UNIT (KDU)
(Continued)

BOOKKEEPING FUNCTIONS—KEYBOARD DISPLAY UNIT (KDU)

Note: When using the Keyboard Display Unit, the information shown on the replay display should be ignored.

The bookkeeping functions and their keypad entry codes are as follows:

Code	Function
0A	Total number of coins inserted into the coin chute.
1A	Telephone in — Number of credits put onto the game by the Remote Control Unit.
2A	Telephone Out — Number of credits removed using the reset button.
2B	Total in (Coins and Replays).
3A	Total actual number of games played.
4A	Total Out (Replays).
5A	Number of times Double or Nothing was played.
6A	Number of Double winners.

After the data in all the bookkeeping registers has been recorded they can be set to zero by entering the key code 99B. Note: The coin-in count (0A) is not affected by the reset code.

The game retains in its memory the number of coins dropped through the coin chute, total number of coins and credits (replays) and the actual number of games played. In addition, occurrences of certain features specific to the game model will be recorded to aid in monitoring overall revenue performance. This data is stored in U45 and U49 on the MPU module (non-volatile CMOS RAMS). A storage battery, connected to U45 and U49 only, provides power whenever the game is turned off (see schematic W-1222, sheet 1, left side). The battery is charged through CR29 while the game is on. Since the standby (quiescent) power consumption of U45 and U49 is in microwatts, a fully charged battery can maintain storage of bookkeeping and score information for months. If memory retention is affected, check for battery failure and/or a leaky charging diode.

B. MECHANICAL

Meters located in the cabinet, near the front door, monitor the following functions:

1. Coins In	All coins passing through the coin chute.
2. Total In	All credits and coins played.
3. Total Out	Credits won on the game.
4. Telephone In	Credits awarded from the Remote Control Unit.
5. Telephone Out	Credits removed from the game with the Reset button on the Remote Control Unit.

The Telephone in and out meters are in parallel with the meters in the Remote Control Unit and duplicate the information on them.

V. GAME ADJUSTMENTS

A. PLAYFIELD PANEL POST ADJUSTMENT

Rebound of the ball on the playfield may be adjusted by changing the rubber rings on the playfield posts. A soft rubber ring will increase the ball rebound and a hard rubber ring will decrease rebound.

B. BACK BOX GAME ADJUSTMENTS (SEE SECTION VII, P. 24)

Caution: Turn off power to game before making back box adjustments. Touch the ground braid frequently to avoid damage to the IC modules from static discharge.

Each game has eight switches located on the MPU module in the back box. These switches allow play to be customized to the location. The switches are contained in one sixteen lead package numbered S1-8. The "On" position is marked on the assembly.

Credits/Coin Adjustments:

The credits per coin are selectable by means of S1-S3. The switch settings allow credits per coin as follows:

S1	S2	S3	Credits/Coin
Off	Off	Off	1/1 Coin
On	On	On	1/1 Coin
On	On	Off	10/1 Coin
Off	On	On	4/1 Coin
On	Off	Off	5/1 Coin
Off	Off	On	1/2 Coin
On	Off	On	5/2 Coin
Off	On	Off	1/3 Coin

Score Multiplier Adjustments:

The position of switches S5 and S6 determines the maximum score multiplication allowed.

<u>S5</u>	<u>S6</u>	<u>Multiplier Limit</u>
Off	On	X6
On	Off	X10
Off	Off	X1
On	On	X1

(Continued)

GAME ADJUSTMENTS

Mechanical Meter Counting Rate

Switch S4 controls the rate of impulses transmitted to the mechanical meters. With the factory-installed meters which are not designed to count more than 10 impulses per second, this switch must remain in the "Off" position. For user-installed high-speed meters, switch S4 should be moved to "On" to obtain a 25 impulse per second counting rate.

C. FRONT DOOR GAME ADJUSTMENTS

Several functions of the Reflex Unit are accessible using the Keyboard Display Unit (see section IV-A).

<u>Code</u>	<u>Function</u>
10A	Reflex Factor
11A	Reflex Ratio

Reflex Unit Adjustments:

The Reflex Factor may be adjusted over a range of one to nine to allow the operator to immediately adjust the game play without changing the long term percentage associated with changing the Reflex Ratio.

Changing the Reflex Factor is accomplished as follows:

Display the Reflex Factor by entering the factor code into the Keyboard (10A). Enter the new value (between 1 and 9) into the keyboard. Depress "Enter". The new value is now loaded into the Reflex Factor register.

The Reflex Ratio may be set to any value between 70 and 99. It comes pre-set from Bally at 76, which approximates a number 3 gear ratio of a mechanical game.

To adjust the Reflex Ratio, display the present value of the ratio by entering the Reflex Ratio code (11A) into the keyboard. Next, enter into the keyboard the new, two digit ratio followed by depressing the "Enter" key. The new value is now stored in the register and the Reflex Circuit will stop at this new ratio during game play.

Note: The range of adjustment for the Reflex Ratio is limited to between 70 and 99 percent. Should the ratio be set to a value outside this range, the game will initialize the ratio back to 76 percent.

VI. ROUTINE MAINTENANCE

A. DIAGNOSTIC TESTS

Prior to activating the built-in test routines, the game must be switched from its normal (play) mode to the diagnostic mode (see Keyboard Display Unit installation, section IV). This is done with the game on, by depressing the KEYBD/CLR Button on the Keyboard Display Unit (KDU). As the game enters the diagnostic mode, all feature lights are turned off, the replay display blanks out and the tilt light is turned on. The KDU (Keyboard Display Unit) may now be used to aid service personnel in the performance of diagnostic routines which either indicate that the game is functioning properly or help isolate faulty circuits for repair.

B. KEYBOARD OPERATION

To start any diagnostic routine, the specific code for that routine must be entered on the keyboard. The codes and the routines they initiate are:

<u>Code</u>	<u>Function</u>
1B	Lamp Test
3B	Cyclic Lamp, Coil & Motor Test
2B	Switch Test

C. TEST PROCEDURE

1. LAMP TEST (1B)

After entering the "1B" code, repeated depressing of the "B" button (8 additional times), sequentially energizes eight groups of lamp circuits. As each group of circuits is energized, the number designating that group will appear on the KDU readout.

The circuit groups are listed in the order they are energized.

<u>Code</u>	<u>Lamp Circuits</u>
8	#25 Magic number 4th card double hit 5th card double hit 6th card double hit
7	3rd card double-double hit 3rd card double hit #22 magic number #3 & #6 double-double card feature 6th card regular win 6th card double-double hit

(Continued)

ROUTINE MAINTENANCE

<u>Code</u>	<u>Lamp Circuits</u>
6	2nd card double-double hit 2nd card double hit #9 magic number #2 & #5 double-double card feature 5th card double-double hit
5	1st card double-double hit 1st card double hit #7 magic number #1 & #4 double-double coin feature 4th card double-double hit 5th card regular win
4	2nd card nothing All card ball lights: #4, #8, #12, #16, #20, #24 All cards red diagonals Double or nothing features 8th coin feature Tilt #1 magic number 4th card 4th card nothing 6th card nothing
3	2nd card regular win 2nd card double 3rd card All cards ball lights: #3, #7, #11, #15, #19, #23 7th coin feature 9th coin feature 11th coin feature Magic number feature Magic number feature hit 4th card regular win 4th card double win 6th card double win
2	1st card nothing 2nd card lite 3rd card nothing All cards hole lights: #2, #6, #10, #14, #18, #22 All cards super line feature 10th coin feature 5th card nothing 6th card Corner and Super Line panel rollovers

(Continued)

ROUTINE MAINTENANCE

<u>Code</u>	<u>Lamp Circuits</u>
1	1st card All cards corner 1st card regular win 1st card double win All card ball lights: #1, #5, #9, #13, #17, #21, #25 3rd card regular win 3rd card double win 5th card 5th card double win

Note: After completing the 1B test, codes for other routines may be entered directly, if any difficulty arises, press the "KEYBD/CLR" button and re-enter the desired code.

2. CYCLIC LAMP, COIL AND MOTOR TEST (3B)

This routine is similar to the 1B lamp test except that the coil and motor circuits of the game are energized with the lamp groups and no further action is required after entering the 3B code. When this is done, the groups of circuits are energized automatically in the same order (#8 thru #1).

The sequence will cycle continuously until another code is entered on the keyboard or the KEYBD/CLR button (or "Game" button) is pressed.

Note: The (3B) cyclic routine was designed as a factory burn-in test to assure proper functioning of components after a period of use.

(Continued)

ROUTINE MAINTENANCE

3. SWITCH TEST (2B)

Remove (5) balls from the game before running the switch test. After entering the 2B code, the keyboard display should read 8 00. The "8" indicates the switch group being monitored and the "00" reports all switches open in that group. Each additional time the "B" button is pressed, the code for the next group of switches being checked will appear on the left hand side of the keyboard display. At the same time, in a game that is working properly, "00" will be displayed on the right hand side of the keyboard readout, to report all switches open. This repeated pressing of the "B" button commands the Main Processing Unit (MPU) to identify and monitor each group of switches sequentially (#8 thru #1, see chart) and return to group #8.

Each switch in the game also has a unique code, based on its group and position numbers. This specific code will be shown only if that particular switch is closed when its group number is selected. Switch codes appear in place of the "00" on the right hand side of the Keyboard display.

Example: If the Key Switch in group #8 is closed, the display will show 8 04.

When two or more switches in the same group are closed, the sum of all closed switches are displayed.

Example: In group #8, if the Replay Button Switch is closed along with the Key Switch, the display will show 8 05.

Note: The code numbers differ sufficiently to allow switch identification by subtraction of the individual switch codes.

If the KDU shows any closed switches during the test described, locate and check for adjustment, tracing associated circuits if necessary.

To complete the 2B routine, step the KDU to group #8 and manually close switches in the group, one at a time. As each switch is actuated, the correct code should appear in the keyboard display. Repeat with groups #7 thru #2 (group #1 is not used). If response is intermittent or does not occur, clean contacts.

Caution: Do not burnish or file switch contacts or damage to gold plating will occur. Clean with unused business card or equivalent only.

(Continued)

ROUTINE MAINTENANCE

<u>GROUP CODE</u>	<u>SWITCH CODE</u>	<u>SWITCH</u>
8	01	Replay Button
	04	Key Switch
	08	"C" Button
	10	"D" Button
	20	"R" Button
	80	Tilt
7	02	Ball Elevator Switch
	04	Ball Trough 1
	08	Ball Trough 2
	10	Ball Trough 3
	20	Ball Trough 4
	80	Coin Switch
6	01	Gate
	02	Super Line Rollover
	04	Corner Rollover
	20	Ball Shooter
5	01	Hole #1
	02	Hole #2
	04	Hole #3
	08	Hole #4
	10	Hole #5
	20	Hole #6
	40	Hole #7
4	01	Hole #8
	02	Hole #9
	04	Hole #10
	08	Hole #11
	10	Hole #12
	20	Hole #13
	40	Remote Control Data 2
	80	Remote Control Data 1
	3	01
02		Hole #15
04		Hole #16
08		Hole #17
10		Hole #18
40		Remote Control Data 0
80		Remote Control Qualifier
2		01
	02	Hole #20
	04	Hole #21
	08	Hole #22
	10	Hole #23
	40	Hole #24
1	01	Hole #25
	40	Hole #25
1	NOT USED	

(Continued)

ROUTINE MAINTENANCE

D. SERVICE HINTS

1. ELECTRONIC

Bally recommends checking out electronic games weekly by performing the diagnostic tests described in Section VI. A complete set of schematic diagrams is provided in Section VIII to use in conjunction with the tests and help locate faulty components.

2. MECHANICAL SWITCHES

a. Tilt Switches

Front door and cabinet tilt switches should be adjusted to have about a 1/16" gap between contacts. The *weighted* blade should be positioned to achieve this gap. A larger gap is less sensitive to tripping and a smaller gap increases sensitivity.

b. Other Switch Assemblies

Tighten assembly mounting screws (closest to contact end first) before adjusting to prevent leaves from fanning out. Leaf springs should be adjusted for a 1/16" gap between contacts in the open position and .010 additional travel upon closing. All contacts are gold plated and must not be filed. Clean by closing on a clean business card and pulling it back and forth three times.

CAUTION: Damage to contacts may occur if abrasive tools are used. Pitted or damaged contacts must be replaced as an assembly. Lubrication should not be used.

3. General

Periodic cleaning of the playfield will extend the life and maintain the appearance of its finish. An excellent cleaner to use is Wildcat #125 compound. If not available locally, ask your distributor to order it from the Wildcat Chemical Company, 1333 Seminary Drive, Ft. Worth, Texas, 76115. Avoid waxing or polishing with products that accumulate residue and yellow with age.

CAUTION: Do not use large amounts of water, caustic or abrasive cleaners.

Inspect each ball every month and polish with a clean cloth. Replace any chipped balls promptly – a chipped ball can damage the playfield in a short time.

Use the printed circuit board removal tool (M-1651-96) when replacing or working on modules. Always disconnect game from main power source *first* and touch the ground braid.

PANEL ASSEMBLY—PLAYFIELD

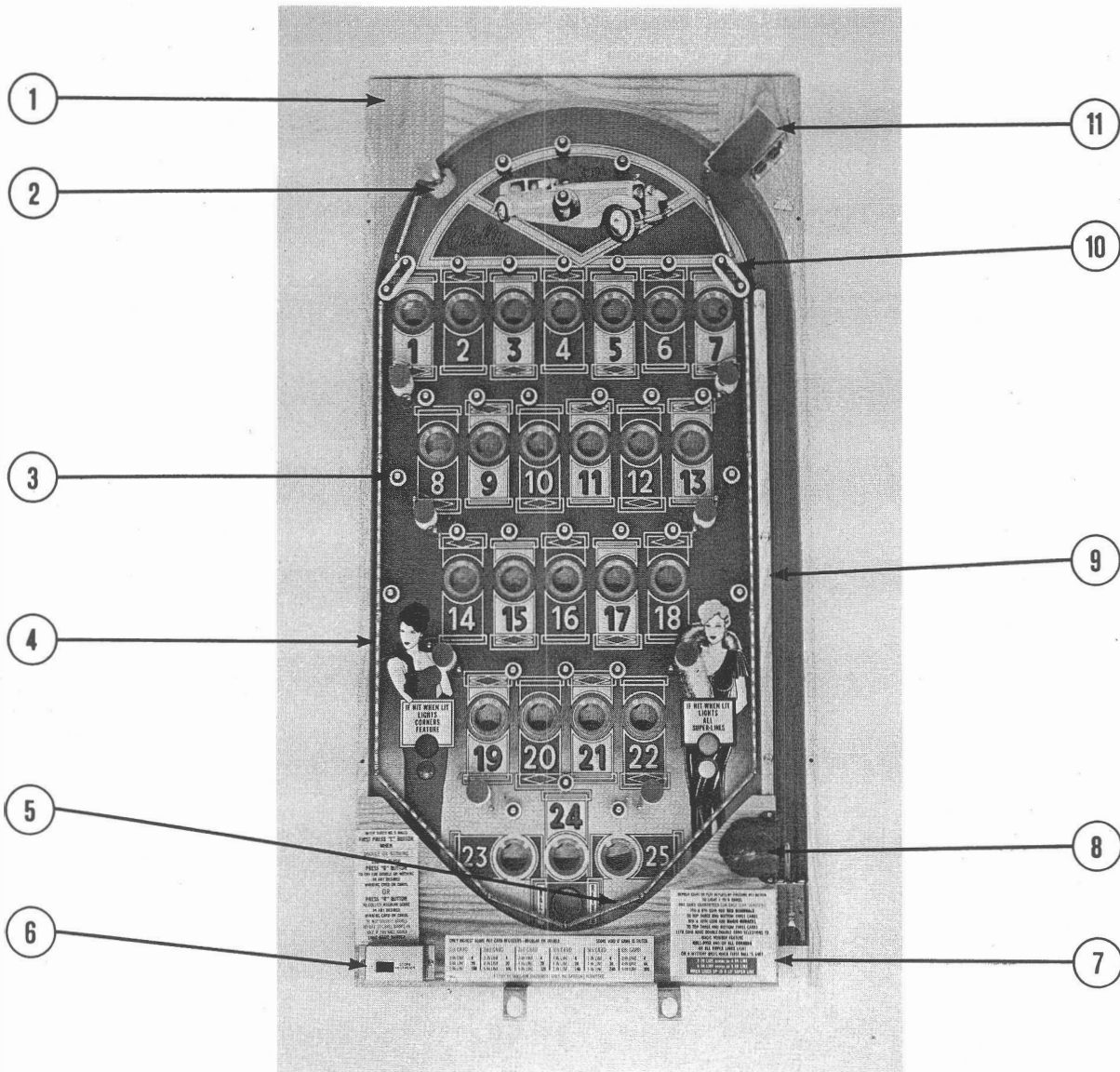

NOTE: ALL SWITCHES ARE DIODE PROTECTED (E-587-6).

Key No.	Part No.	Description	Page
1	CA-1104	Arch Top	
2	R-115-4	Rebound Rubber	
3	R-243	Bumper Rubber — White.	13
4	SP-112	Long Panel Spring	
5	SP-112-1	Short Panel Spring	
6	AS-3069	Multiplier Display Assy.	2
7	CA-1100-12	Front Arch (BEL)	
8	C-153	Ball Lifter Cover	
9	R-243-2	Bumper Rubber — Grey	13
10	CA-1103	Arch Guide Strip	
11	R-521-1	Bumper Rubber — Two Post	13
12	AS-1315-9	Ball Gate & Switch Assy.	

PANEL ASSEMBLY—BOTTOM

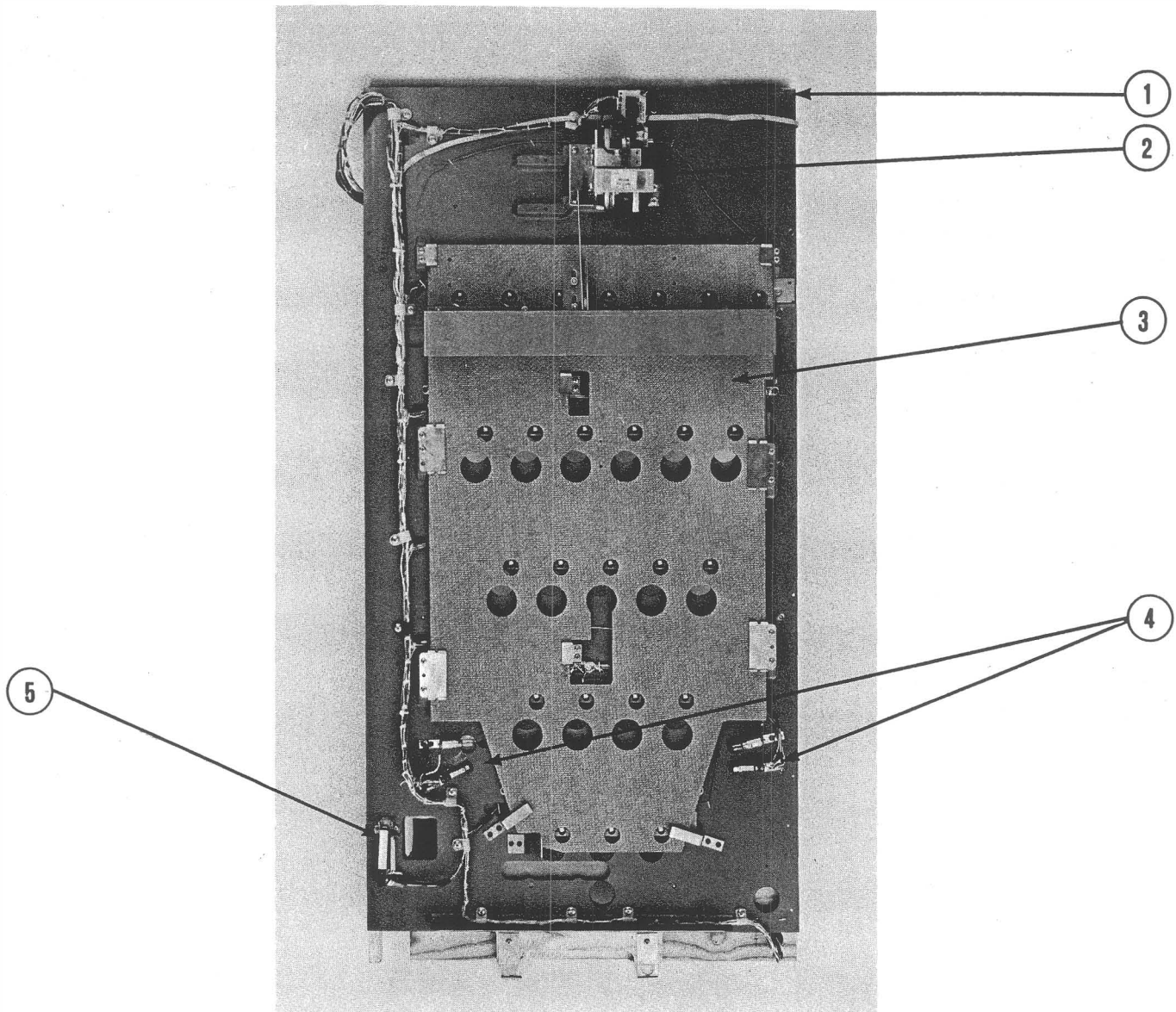

ALL SWITCHES ARE DIODE PROTECTED (E-587-6).

Key No.	Part No.	Description
1	CAP-638-117	Panel
2	AS-232-107	Shutter Motor Assy. (BEL)
3	AS-1433-20	Shutter Assy.
4	ASW-A1-177	Rollover Switches
5	ASW-A1-178	Ball Runway Switch

FRONT CABINET

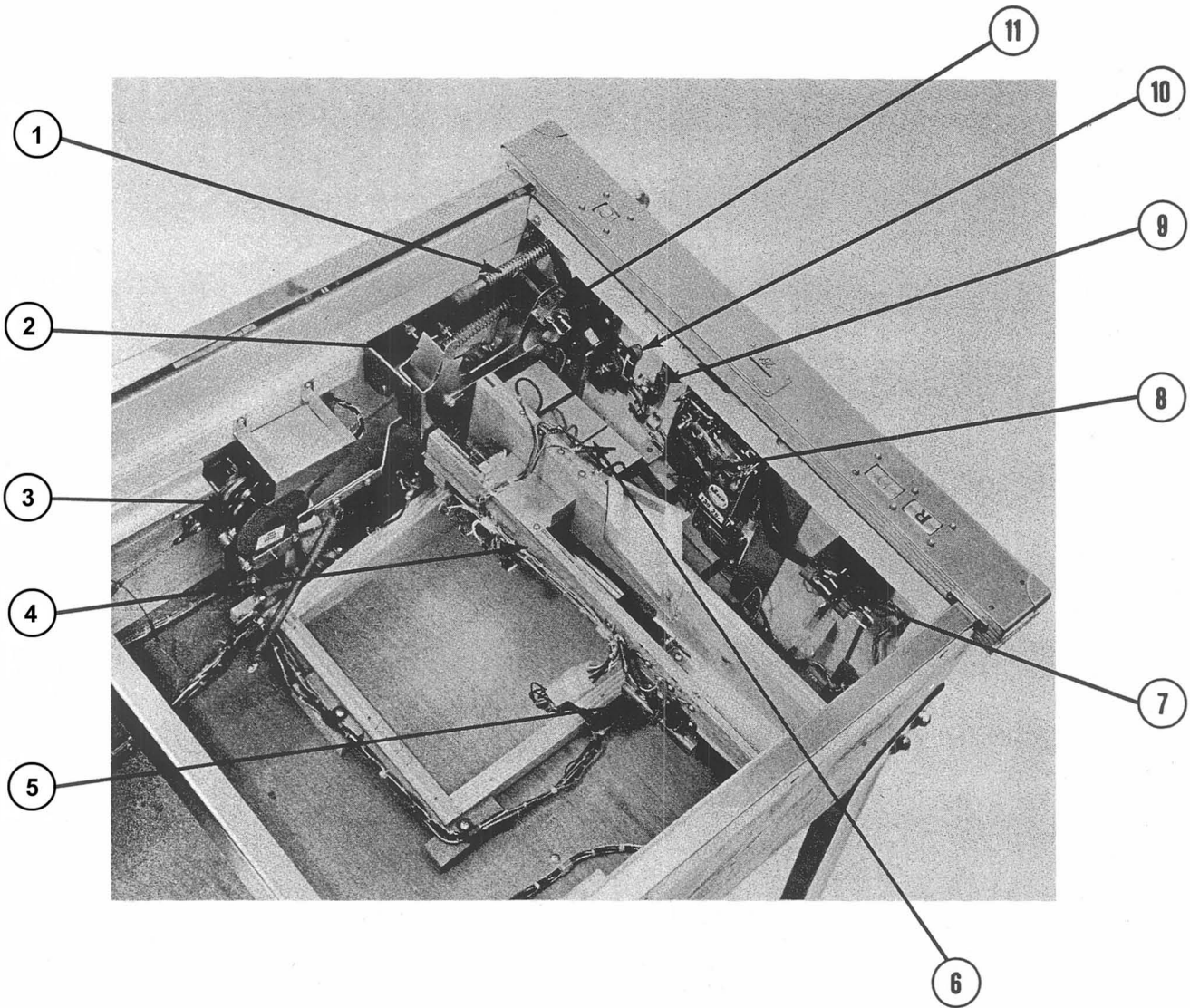

No.	Part No.	Description	Page
1	AS-187-20	Ball Shooter Assy.	
2	AS-186-18	Ball Lifter Assy.	
3	AS-1139-39	Ball Lifter Motor Assy.	
4	AS-1145-61	Ball Trough & Switch Assy.	
5	E-130-29	Tele In & Out Meters	12
6	E-130-29	Coin and Total In & Out Meters	12
7	AS-982-1281	"R" & "D" Switch & Bracket Assy.	
8	AS-277-172	Coin Switch	
9	ASW-A1-180	Red Button Switch	
10	ASW-A1-183	Tilt Switch	
11	ASW-A1-173	"C" Button Switch	

BACK BOX

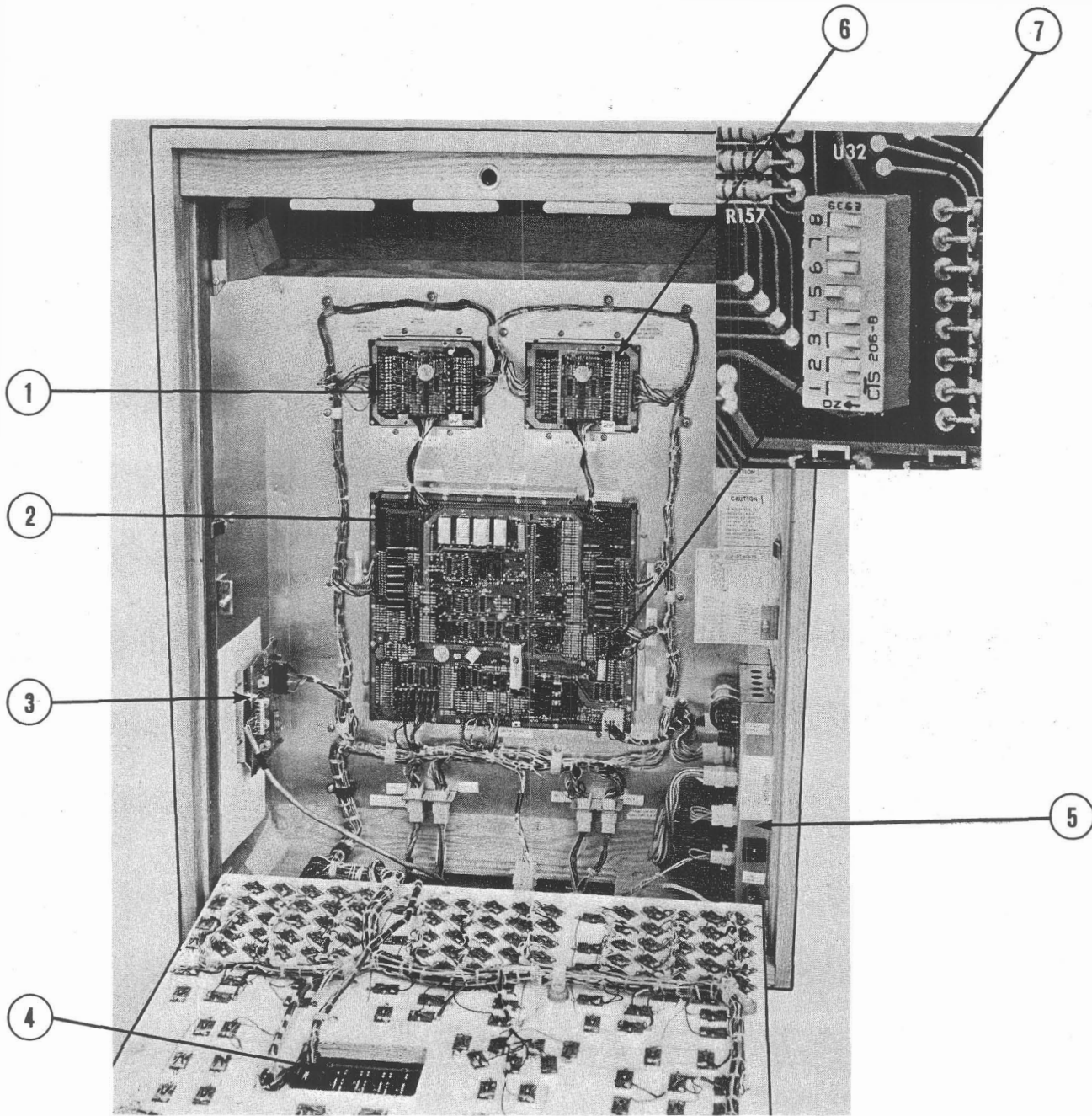

Key No.	Part No.	Description	Page
1	AS-3050	Lamp Driver Assy. (LDA)	25
2	ASE-3044	Microprocessor Assy. (MPU)	26
3	AS-3058	Remote Control Receiver (RCR)	10
4	ASE-3042	Electronic Replay Assy.	9
5	AS-3040	Power Supply Assy. (PSU)	
6	AS-3045	Lamp Driver Assy. (LDB)	25
7	E-677	Adjustment Switches (Detail)	13

LAMP DRIVER UNIT—LOW CURRENT (LDA)

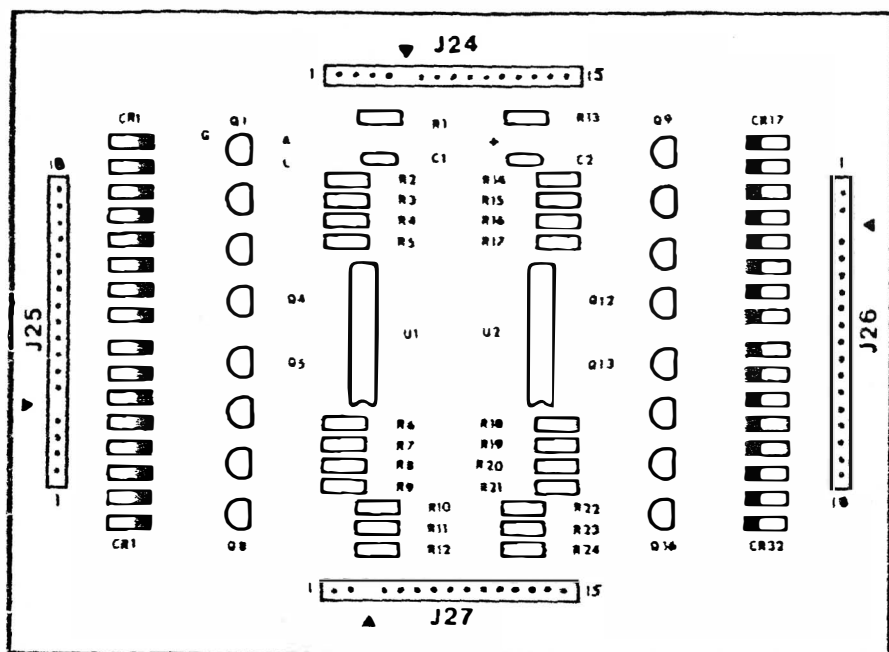

REF.	VALUE	DESCRIPTION
U1 - U2	MC140158CP	DUAL 4-BIT SHIFT REGISTER
Q1 THRU Q16	2N5060	S.C.R.
CR1 THRU CR32	1N4004	DIODE
R1		
R2 THRU R9	4.7K OHM, 1/4 W. 5%	RESISTOR
R10 THRU R12	2.2K OHM, 1/4 W. 5%	RESISTOR
R13	1 MEG OHM, 1/4 W. 5%	RESISTOR
R14 THRU R21	4.7K OHM, 1/4 W. 5%	RESISTOR
R22 THRU R24	2.2K OHM, 1/4 W. 5%	RESISTOR
C1	.1 MFD, 100 V	CAPACITOR (AXL)
C2	4.7 MFD, 25 V	CAPACITOR (TANT)
J24 AND J27	15 PIN	KK-100 WAFER
J28 - J29	18 PIN	KK-100 WAFER
	M 645 455	P.C. BOARD

LAMP DRIVER UNIT—HIGH CURRENT (LDB)

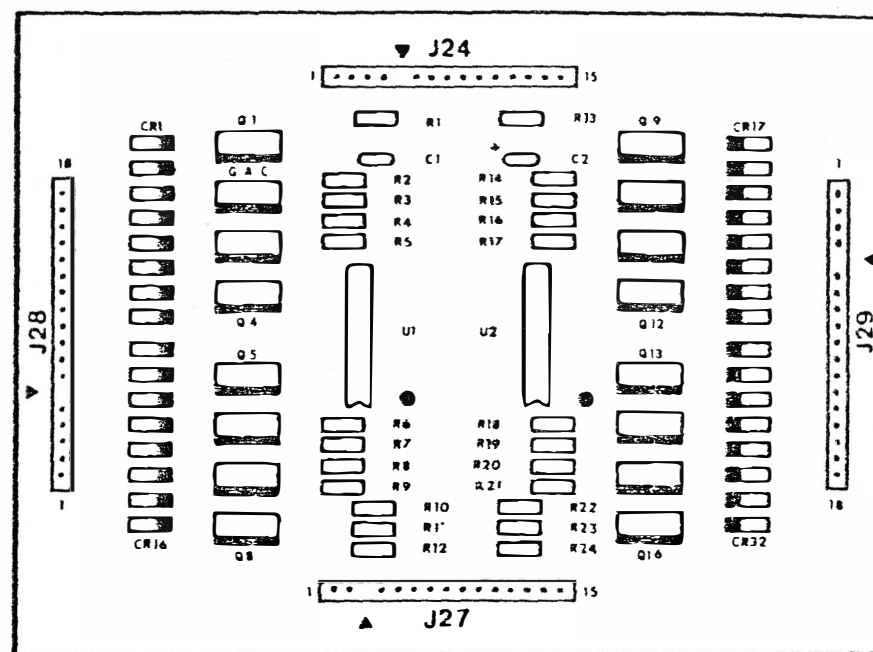

REF.	VALUE	DESCRIPTION
U1 - U2	MC140158CP	DUAL 4-BIT SHIFT REGISTER
Q1 THRU Q16	MCR106-1 (OR EQUIV)	S.C.R.
CR1 THRU CR32	1N4004	DIODE
R1		
R2 THRU R9	4.7K OHM, 1/4 W. 5%	RESISTOR
R10 THRU R12	2.2K OHM, 1/4 W. 5%	RESISTOR
R13	1 MEG OHM, 1/4 W. 5%	RESISTOR
R14 THRU R21	4.7K OHM, 1/4 W. 5%	RESISTOR
R22 THRU R24	2.2K OHM, 1/4 W. 5%	RESISTOR
C1	.1 MFD, 100 V	CAPACITOR (AXL)
C2	4.7 MFD, 25 V	CAPACITOR (TANT)
J24 AND J27	15 PIN	KK-100 WAFER
J28 - J29	18 PIN	KK-100 WAFER
	M 645 456	P.C. BOARD

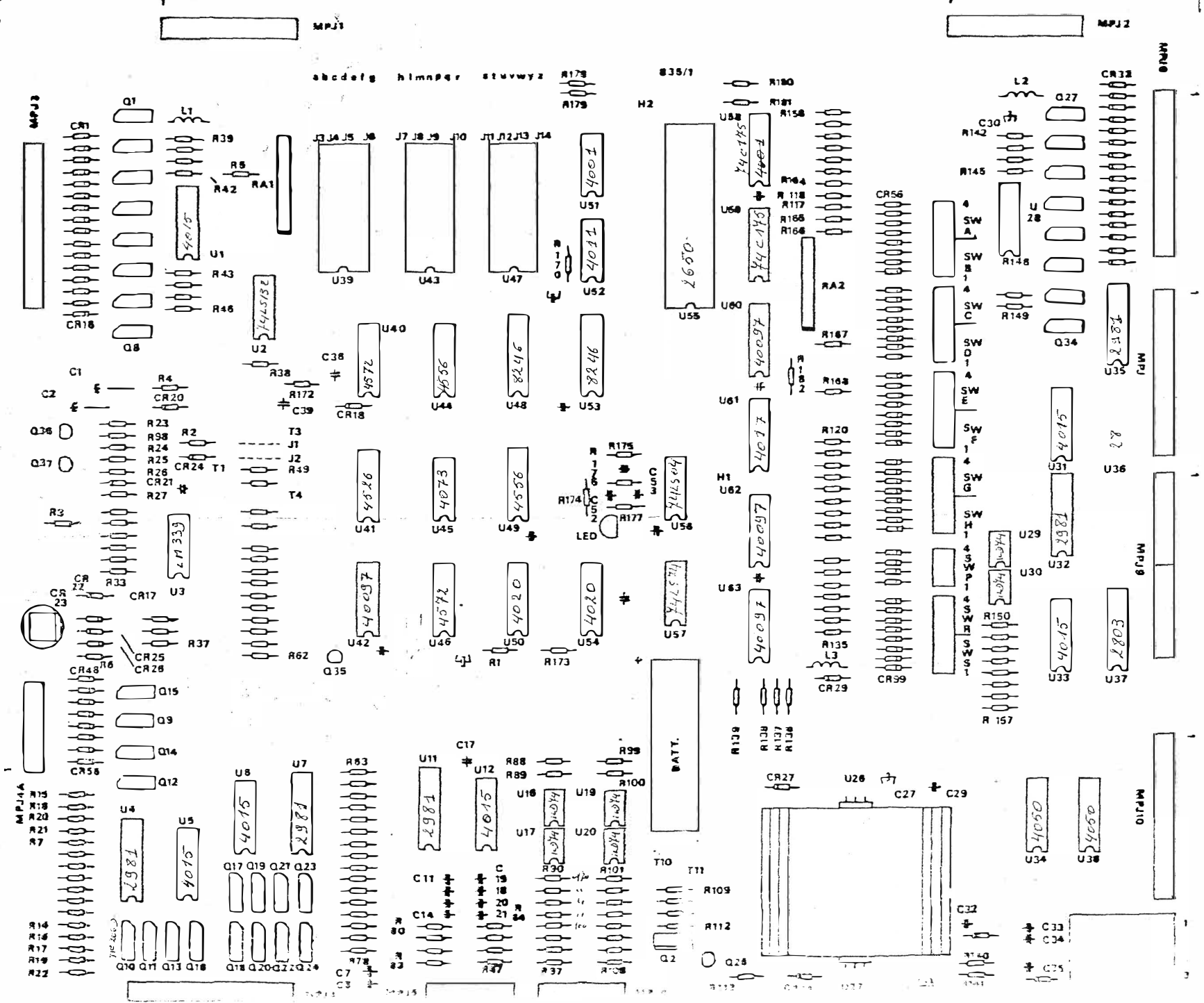
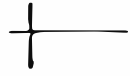

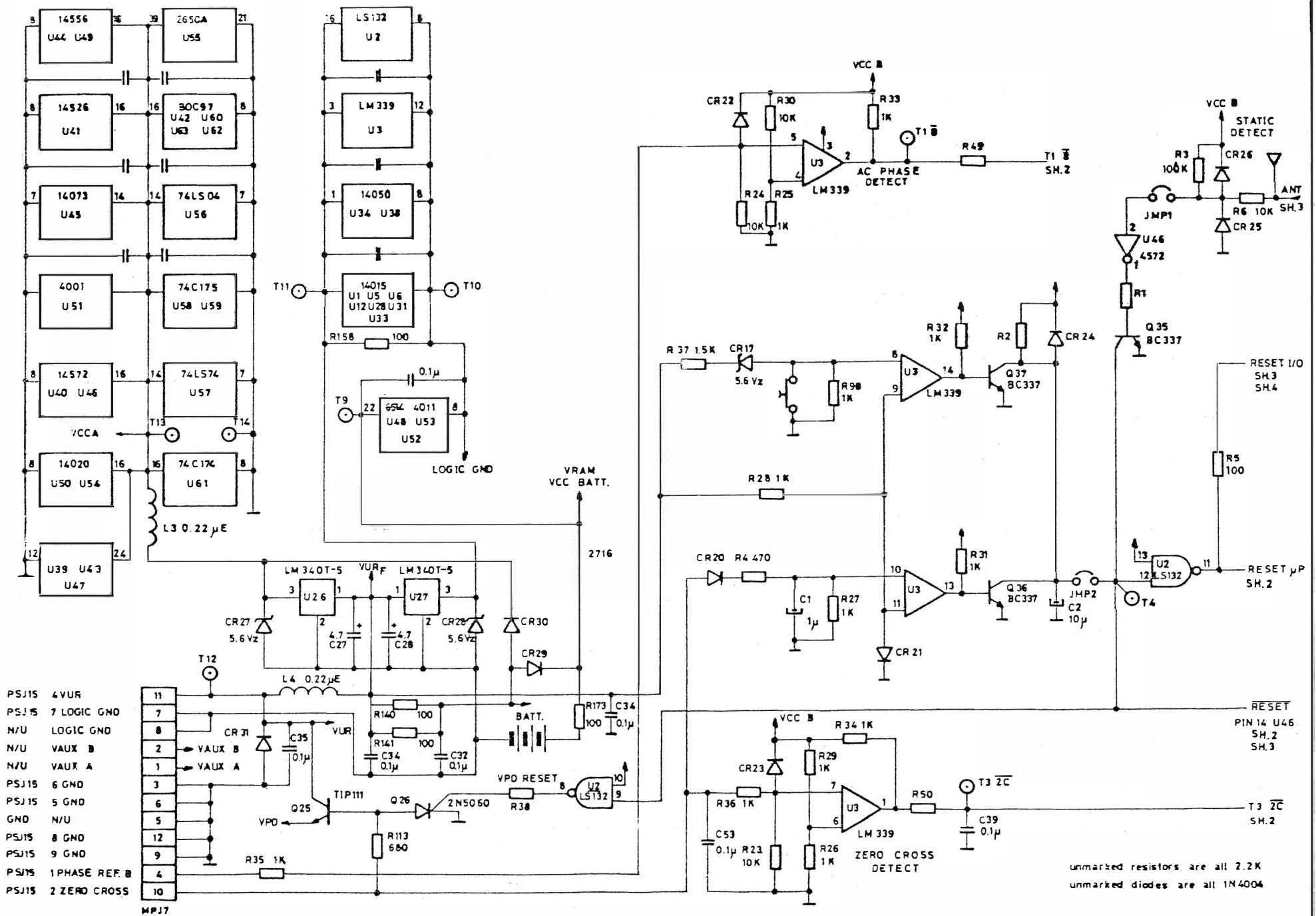

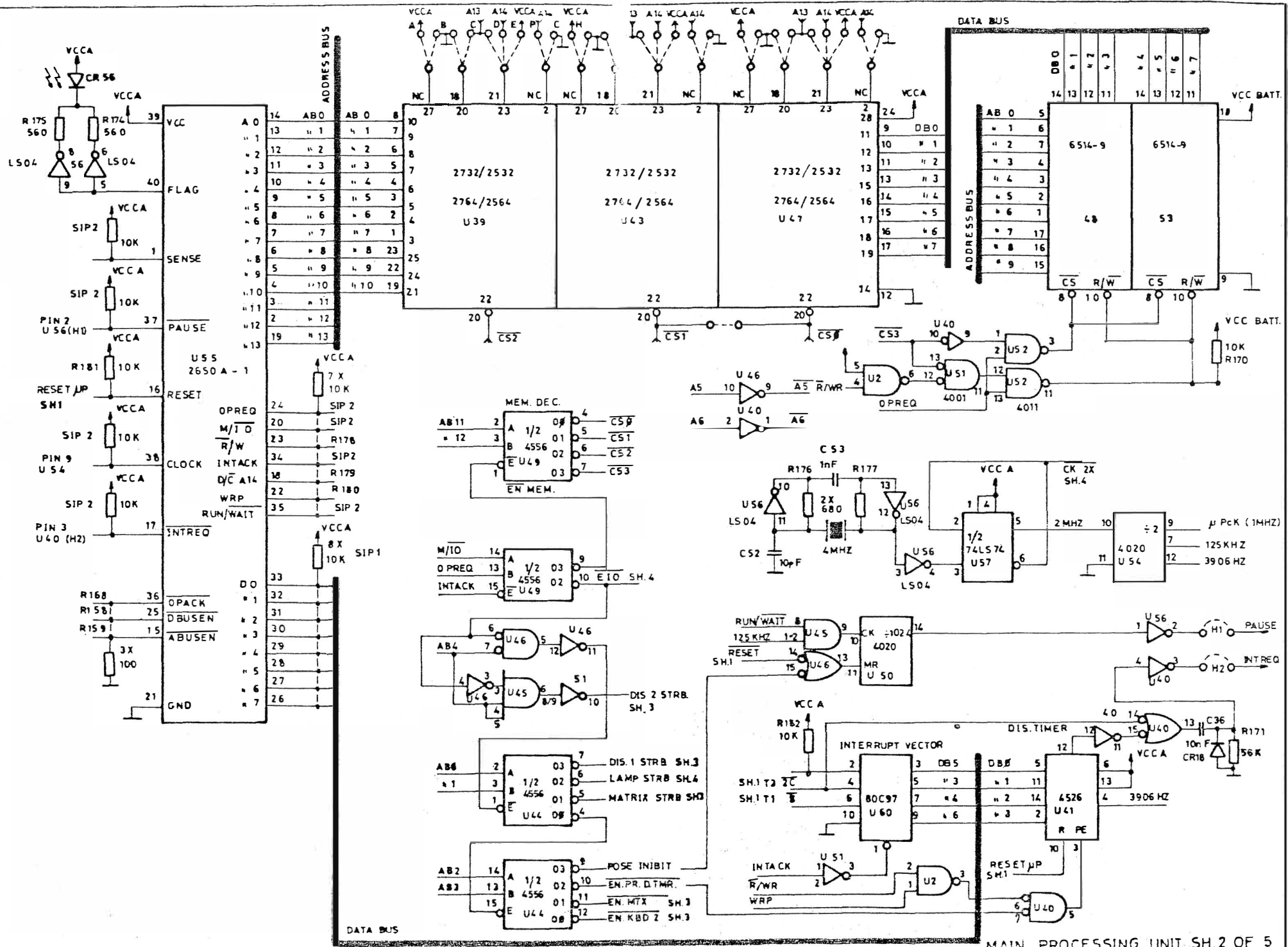

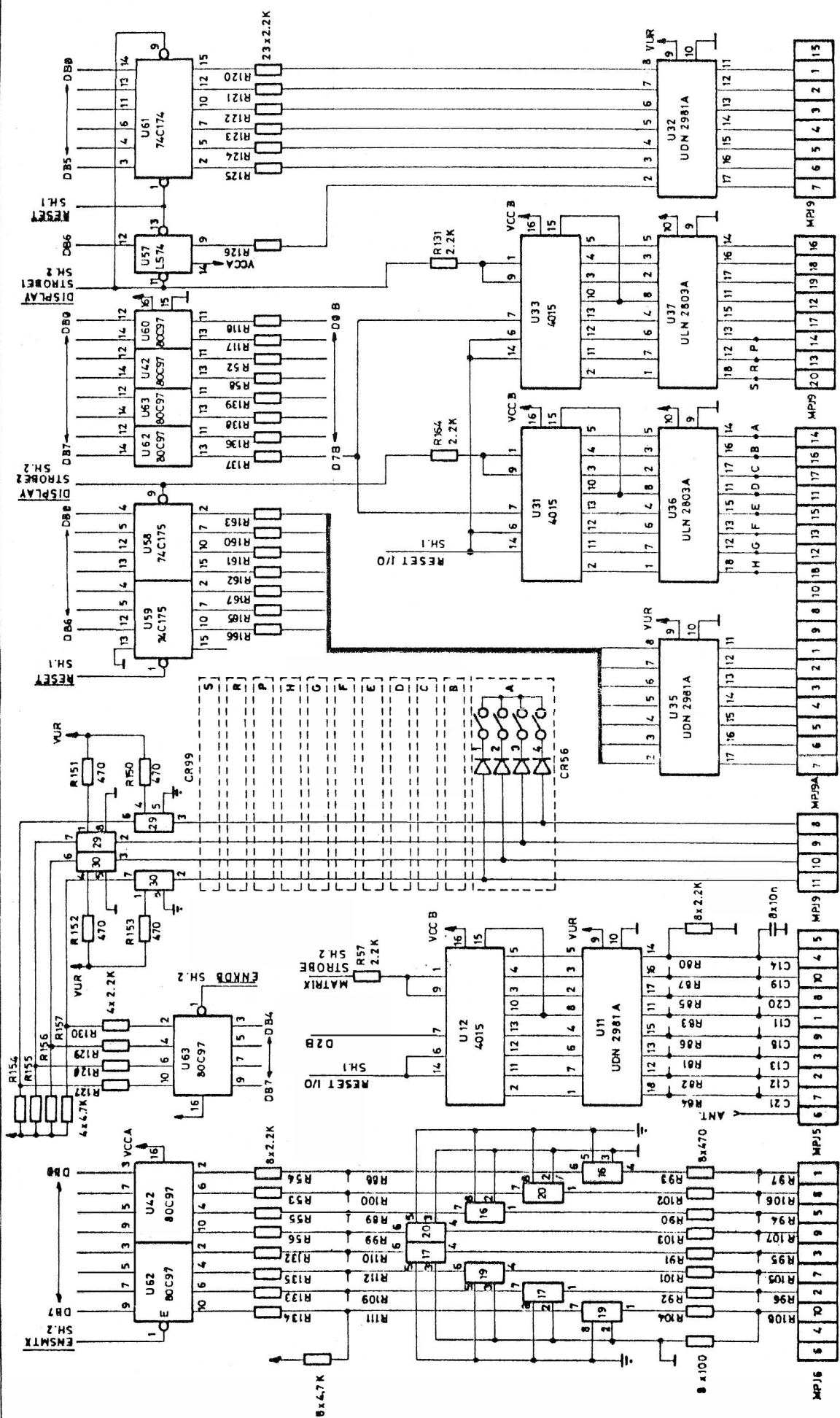

- NU. KEY
- 82-1 BRC-9 RTN8
- 72-1 BRF-12 RTN7
- 62-1 BRC-8 & BRF-10 RTN8
- 52-1 BRC-7 & BRF-8 RTN8
- 43-1 BRC-6 & BRF-6 RTN4
- 32-1 BRC-5 & BRF-4 RTN3
- 23-1 BRC-4 & BRF-1-8 RTN2
- 13-1 BRC-2 & BRF-1-1 RTN1
- 23 BRC-6 & BRF-2-3 ANT
- NU. BRF-1-11 S107
- 71-1 BRF-1-9 S108
- 61-1 BRF-1-7 S105
- 41-1 BRF-1-5 S104
- 31-1 BRF-1-3 S103
- 21-1 BRC-4-3 S102
- 12-1 BRC-4-1 S101
- KEY
- 13-5 RRJ19-11 NRD4
- 14-5 RRJ19-10 NRD5
- 15-5 RRJ19-9 NRD6
- 16-5 RRJ19-8 NRD7
- RRJ19A-7 SEC. G
- RRJ19A-6 SEC. F
- RRJ19A-5 SEC. E
- RRJ19A-4 SEC. D
- RRJ19A-3 SEC. C
- RRJ19A-2 SEC. B
- RRJ19A-1 SEC. A
- RRJ19A-12 DIG. STM. 8
- RRJ19A-10 DIG. STM. 7
- RRJ19A-9 DIG. STM. 6
- RRJ19A-8 DIG. STM. 5
- RRJ19A-14 DIG. STM. 3
- RRJ19A-13 DIG. STM. 2
- RRJ19A-11 DIG. STM. 1
- 81-5 RRJ19-20 S108
- 71-5 RRJ19-13 S107
- 61-5 RRJ19-14 S106
- 51-5 RRJ19-17 S105
- 12-5 RRJ19-12 S104
- 31-5 RRJ19-19 S103
- 21-5 RRJ19-18 S102
- 12-5 RRJ19-16 S101
- 36-5 RRJ19-7 SEC. G
- 35-5 RRJ19-6 SEC. F
- 34-5 RRJ19-5 SEC. E
- 27-5 RRJ19-3 SEC. C
- 23-5 RRJ19-2 SEC. B
- 23-5 RRJ19-1 SEC. A
- KEY

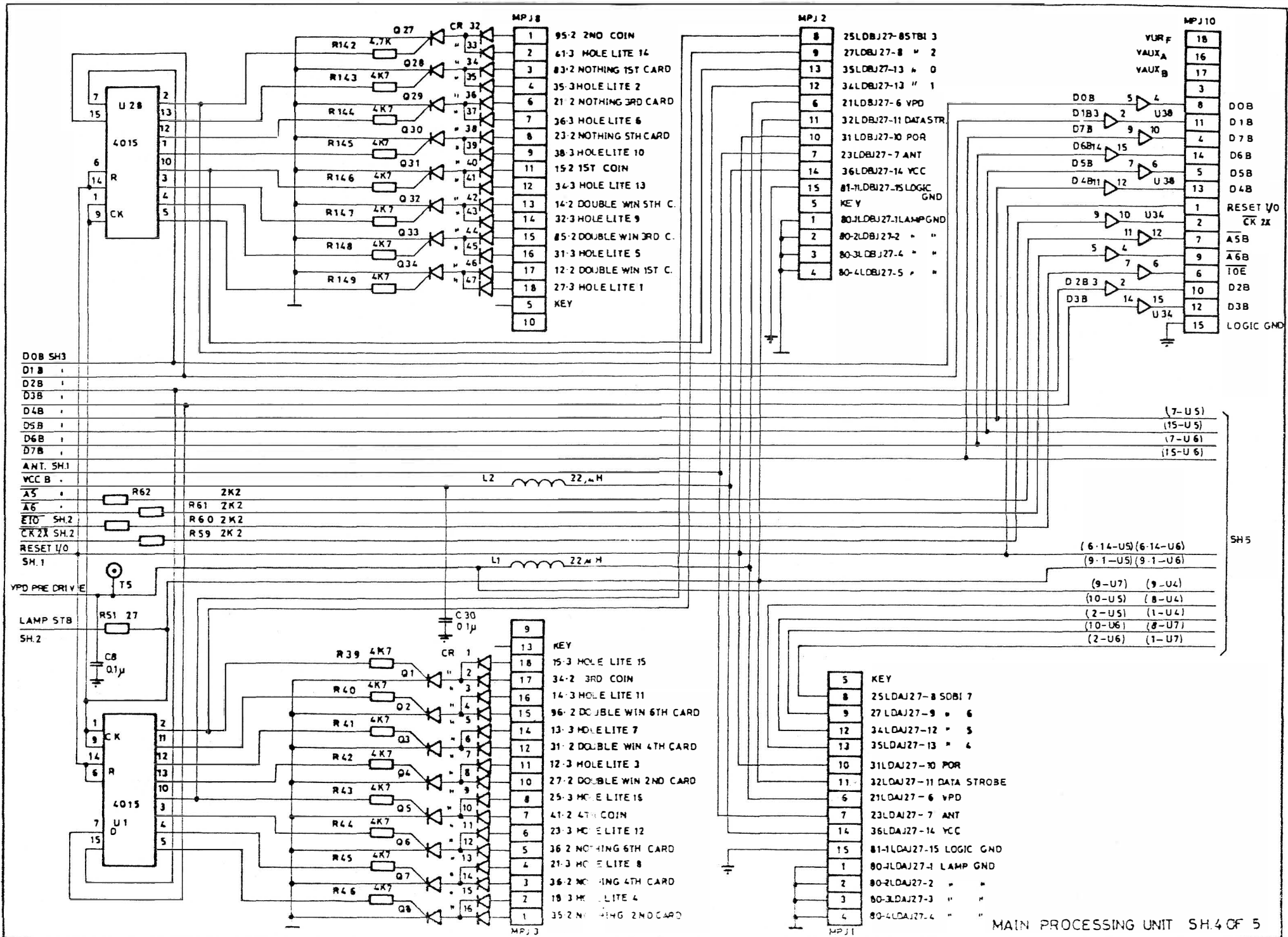

SH4

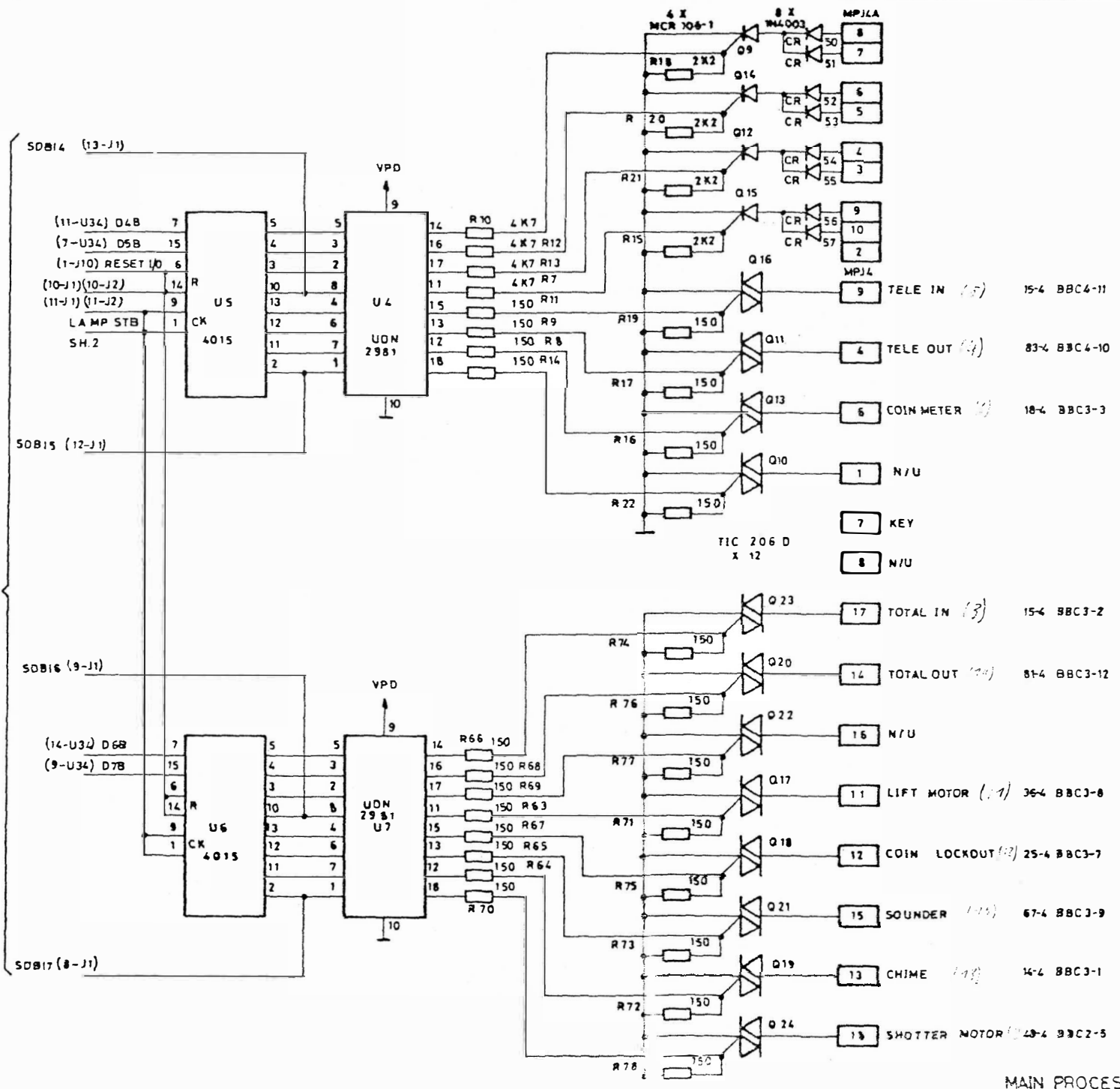

- 13-5 MPJ9 11
- 14-5 MPJ9 10
- 15-5 MPJ9 9
- 16-5 MPJ9 8
- 12-5 MPJ9 16
- 21-5 MPJ9 18
- 31-5 MPJ9 19
- 41-5 MPJ9 12
- 00
- KEY
- 15
- 81-5 MPJ9 20
- 71-5 MPJ9 13
- 61-5 MPJ9 14
- 51-5 MPJ9 17
- 01
- 36-5 MPJ9 7
- 35-5 MPJ9 6
- 34-5 MPJ9 5
- 32-5 MPJ9 4
- 27-5 MPJ9 3
- 25-5 MPJ9 2
- 23-5 MPJ9 1

11	KEYBOARD RETURN D4
10	KEYBOARD RETURN D5
9	KEYBOARD RETURN D6
8	KEYBOARD RETURN D7
16	DIGIT STROBE 1
18	DIGIT STROBE 2
19	DIGIT STROBE 3
12	DIGIT STROBE 4
00	
15	KEY
20	DIGIT STROBE 8
13	DIGIT STROBE 7
14	DIGIT STROBE 6
17	DIGIT STROBE 5
01	
7	SEGMENT "G"
6	SEGMENT "F"
5	SEGMENT "E"
4	SEGMENT "D"
3	SEGMENT "C"
2	SEGMENT "B"
1	SEGMENT "A"

- 11 13-5 KDUP 19 11
- 10 14-5 KDUP 19 10
- 9 15-5 KDUP 19 9
- 8 16-5 KDUP 19 8
- 16 12-5 KDUP 19 16
- 18 61-5 KDUP 19 18
- 19 71-5 KDUP 19 19
- 12 31-5 KDUP 19 12
- 00
- 15 KEY
- 20 41-5 KDUP 19 20
- 13 21-5 KDUP 19 13
- 14 51-5 KDUP 19 14
- 17 12-5 KDUP 19 17
- 01
- 7 36-5 KDUP 19 7
- 6 35-5 KDUP 19 6
- 5 34-5 KDUP 19 5
- 4 32-5 KDUP 19 4
- 3 27-5 KDUP 19 3
- 2 25-5 KDUP 19 2
- 1 23-5 KDUP 19 1

RRJ19

RRJ20

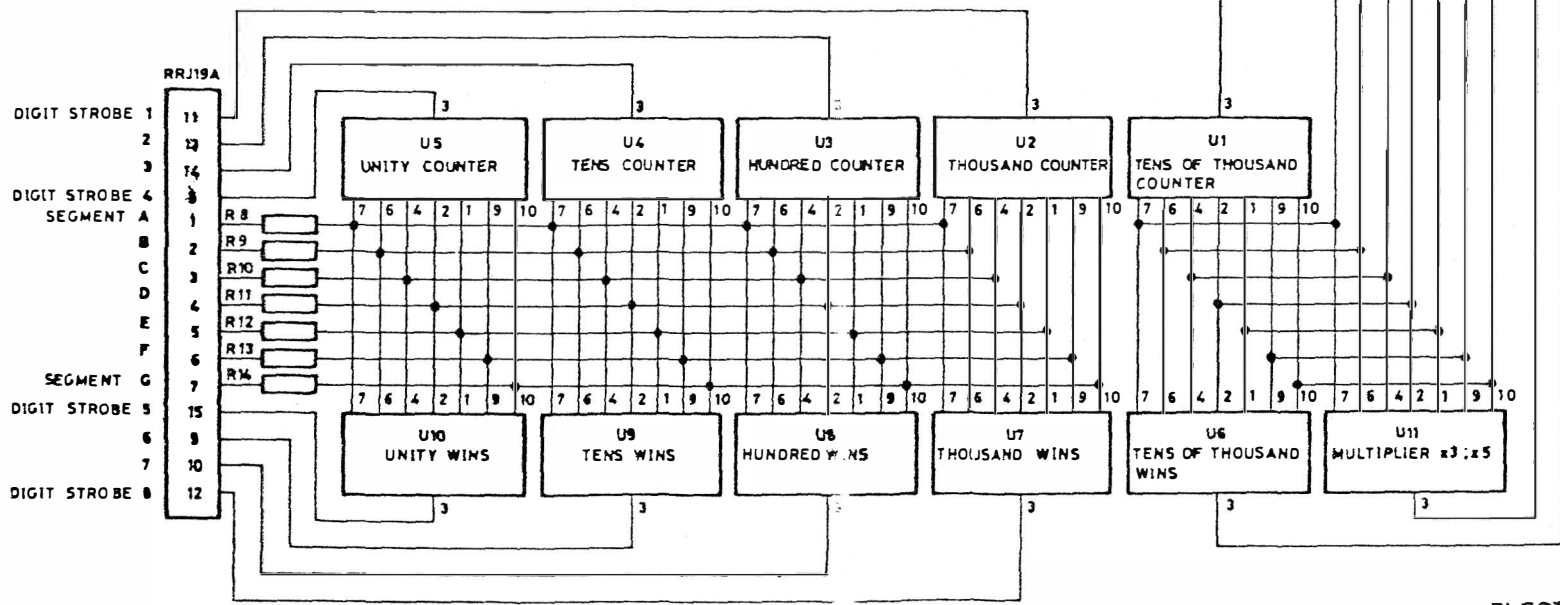
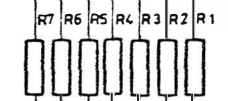

ALL RESISTORS ARE 100Ω 1/2 W
ALL DISPLAYS ARE FND500

ELECTRONIC DISPLAY REGISTER

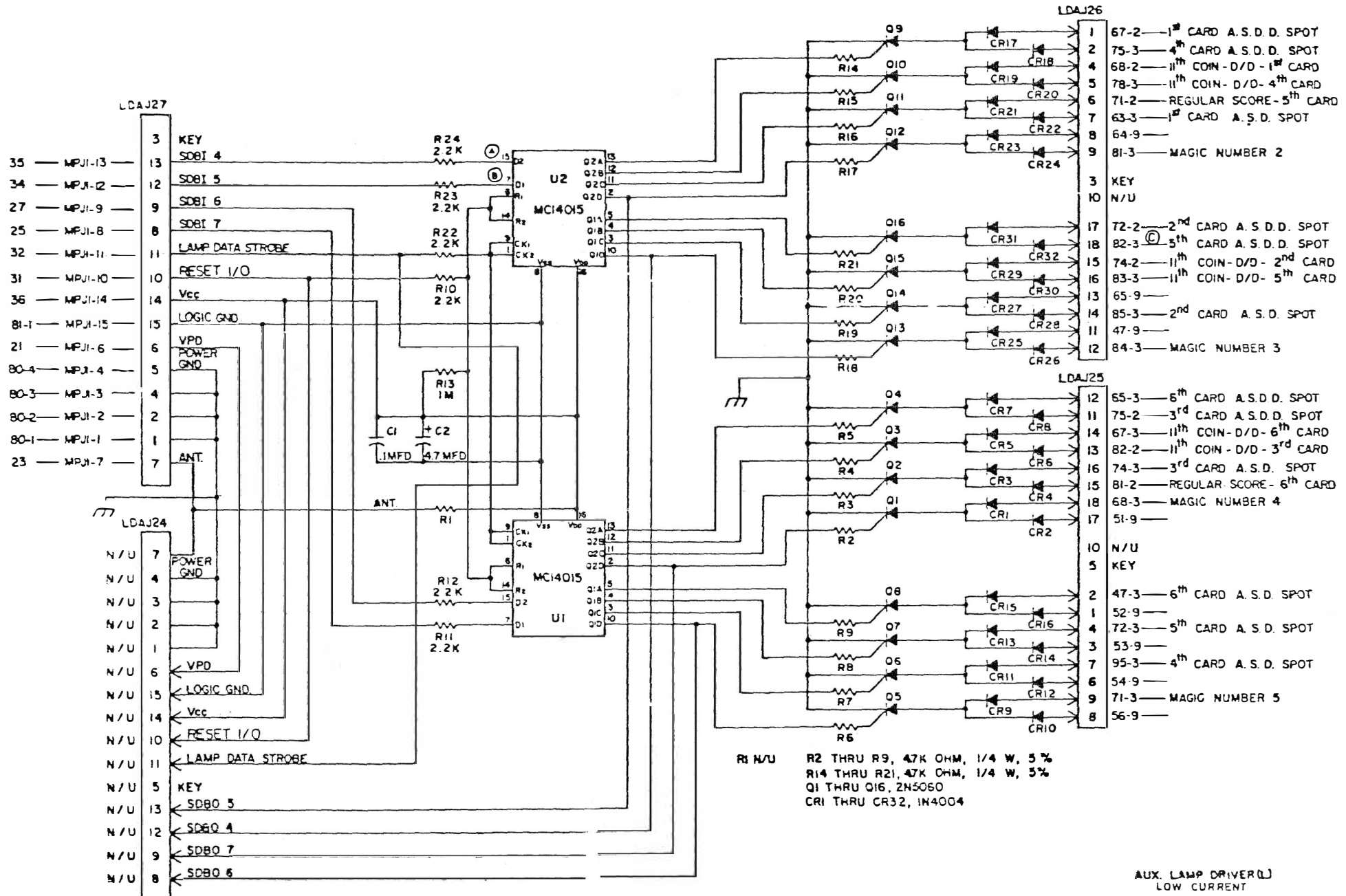

AUX. LAMP DRIVER (J)
LOW CURRENT

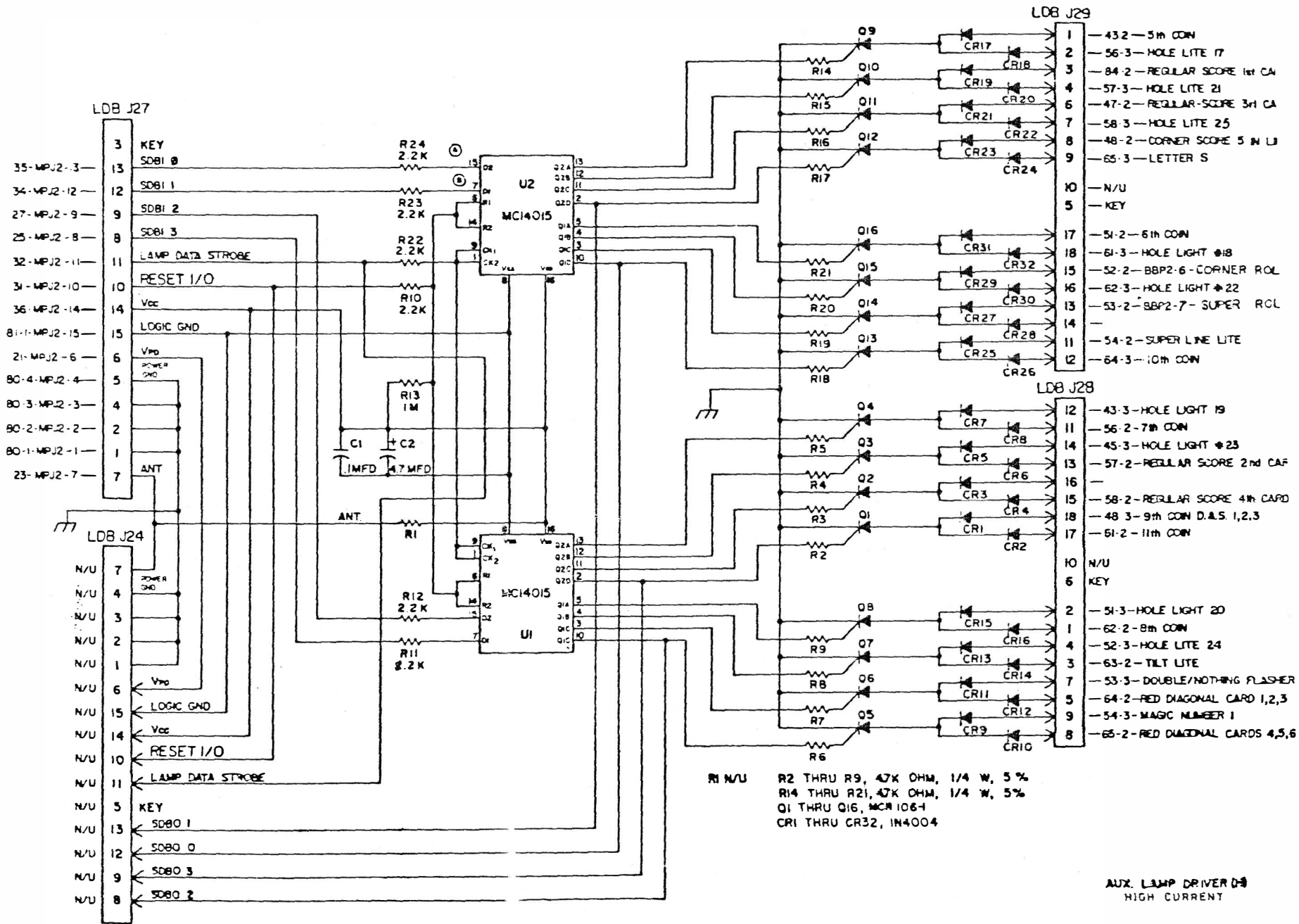

- LDB J27**
- 35-MPJ2-3
 - 34-MPJ2-12
 - 27-MPJ2-9
 - 25-MPJ2-8
 - 32-MPJ2-11
 - 31-MPJ2-10
 - 36-MPJ2-14
 - 8-1-MPJ2-15
 - 21-MPJ2-6
 - 80-4-MPJ2-4
 - 80-3-MPJ2-3
 - 80-2-MPJ2-2
 - 80-1-MPJ2-1
 - 23-MPJ2-7

- LDB J24**
- N/U 7
 - N/U 4
 - N/U 3
 - N/U 2
 - N/U 1
 - N/U 6
 - N/U 15
 - N/U 14
 - N/U 10
 - N/U 11
 - N/U 5
 - N/U 13
 - N/U 12
 - N/U 9
 - N/U 8

- LDB J29**
- 1 -43-2-5th COIN
 - 2 -56-3-HOLE LITE 17
 - 3 -84-2-REGULAR SCORE 1st CA
 - 4 -57-3-HOLE LITE 21
 - 6 -47-2-REGULAR SCORE 3rd CA
 - 7 -58-3-HOLE LITE 25
 - 8 -48-2-CORNER SCORE 5th LI
 - 9 -65-3-LETTER S
 - 10 -N/U
 - 5 -KEY
 - 17 -51-2-6th COIN
 - 18 -61-3-HOLE LIGHT #18
 - 15 -52-2-BBP2-6-CORNER ROL
 - 16 -62-3-HOLE LIGHT #22
 - 13 -53-2-BBP2-7- SUPER ROL
 - 14 -
 - 11 -54-2-SUPER LINE LITE
 - 12 -64-3-10th COIN

- LDB J28**
- 11 -43-3-HOLE LIGHT 19
 - 12 -56-2-7th COIN
 - 14 -45-3-HOLE LIGHT #23
 - 13 -57-2-REGULAR SCORE 2nd CAF
 - 15 -
 - 16 -58-2-REGULAR SCORE 4th CARD
 - 18 -48-3-9th COIN D.A.S. 1,2,3
 - 17 -61-2-11th COIN
 - 10 -N/U
 - 6 -KEY
 - 2 -51-3-HOLE LIGHT 20
 - 1 -62-2-8th COIN
 - 4 -52-3-HOLE LITE 24
 - 3 -63-2-TILT LITE
 - 7 -53-3-DOUBLE/NOTHING FLASHER
 - 5 -64-2-RED DIAGONAL CARD 1,2,3
 - 9 -54-3-MAGIC NUMBER 1
 - 8 -65-2-RED DIAGONAL CARDS 4,5,6

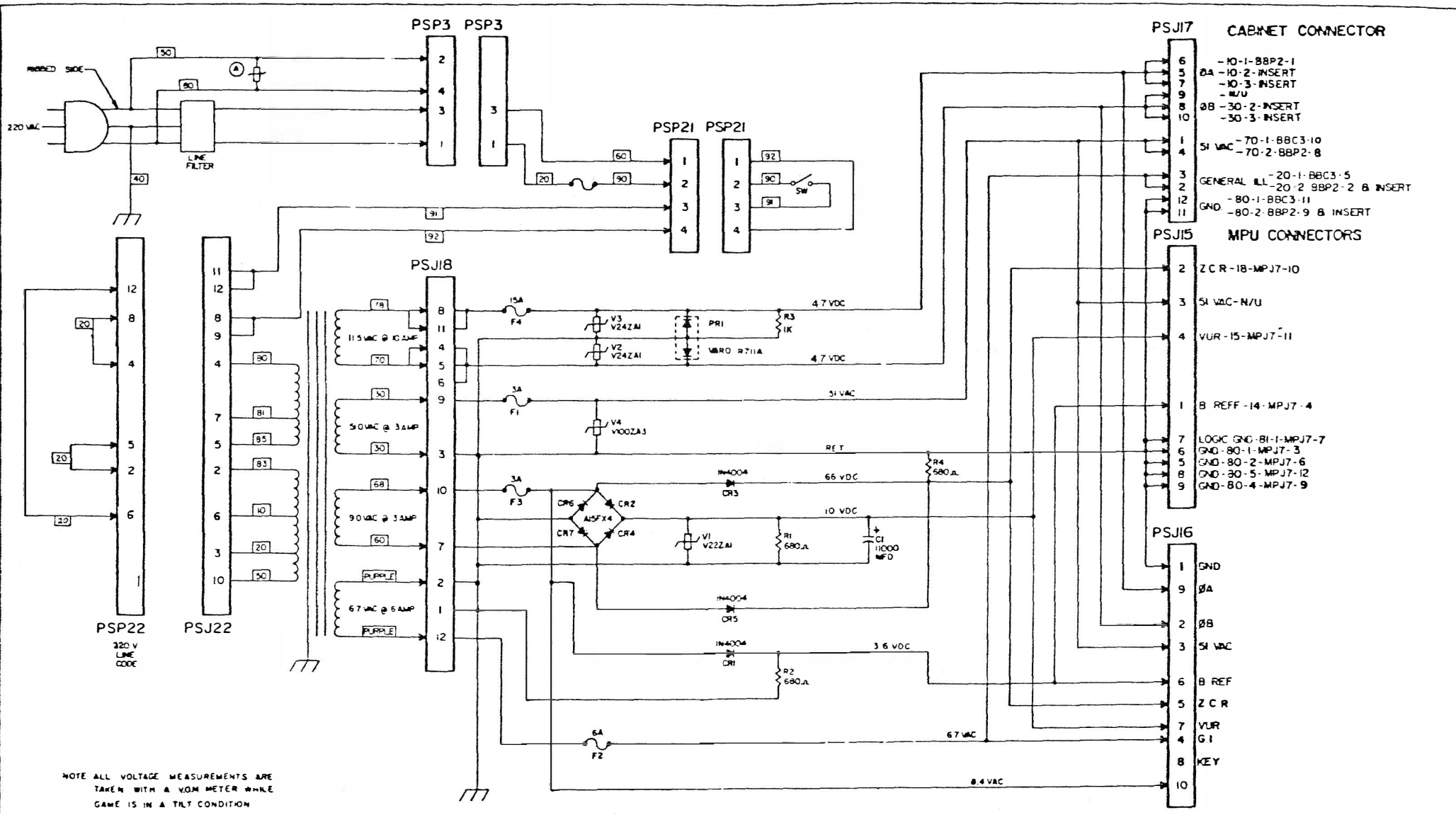

NOTE ALL VOLTAGE MEASUREMENTS ARE TAKEN WITH A VOM METER WHILE GAME IS IN A TILT CONDITION

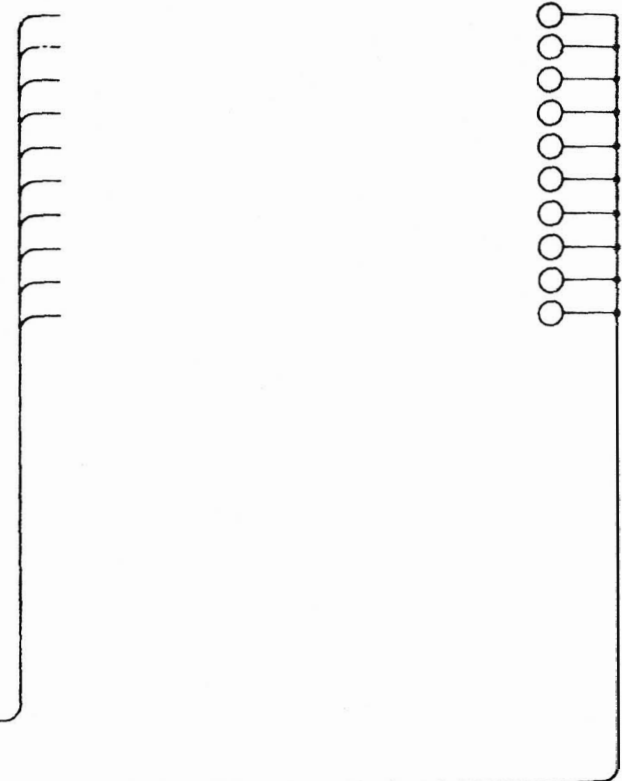
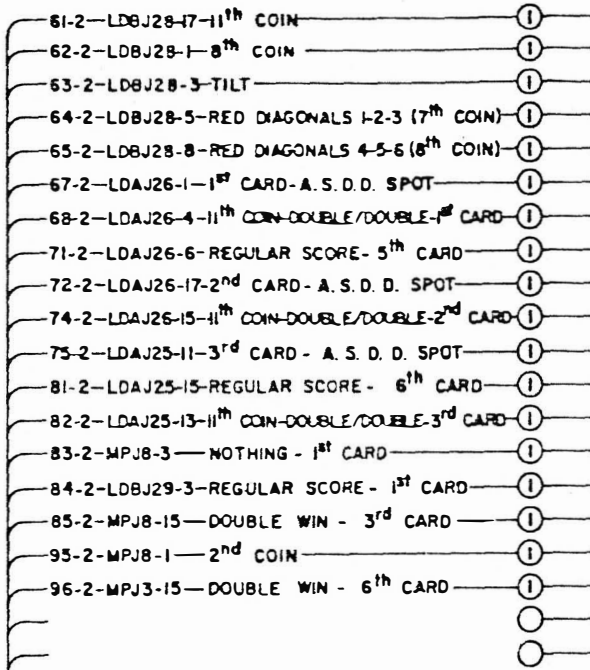
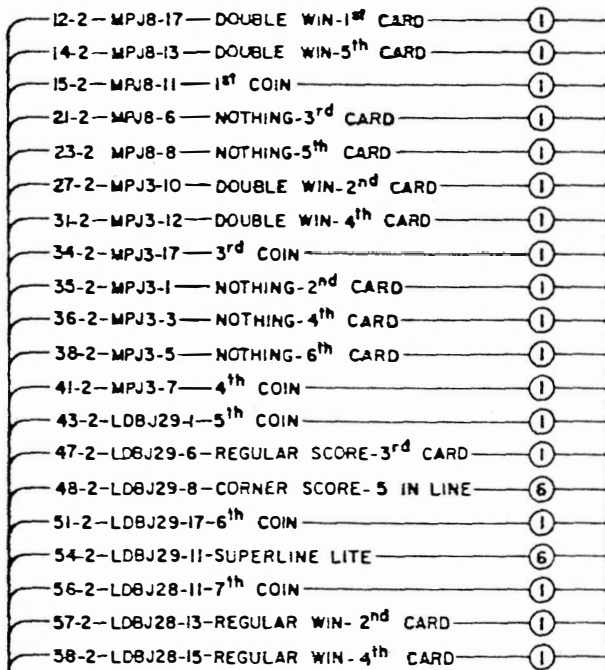

10-2 PSJ17-5
10-3 PSJ17-7 ⚡

NOTE:
VALUES INSIDE LAMP SYMBOLS INDICATE THE NUMBER OF LAMPS PER CIRCUIT.
GENERAL ILLUMINATION CIRCUIT IS CONNECTED TO BOTH PHASES.

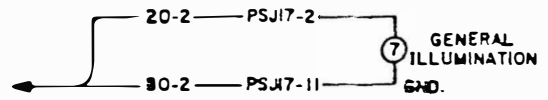

INSERT WIRING DIAGRAM
"A" PHASE

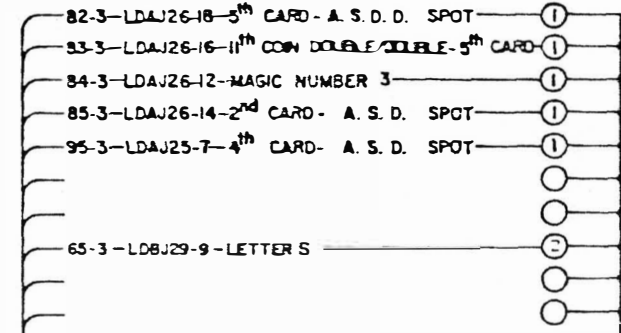
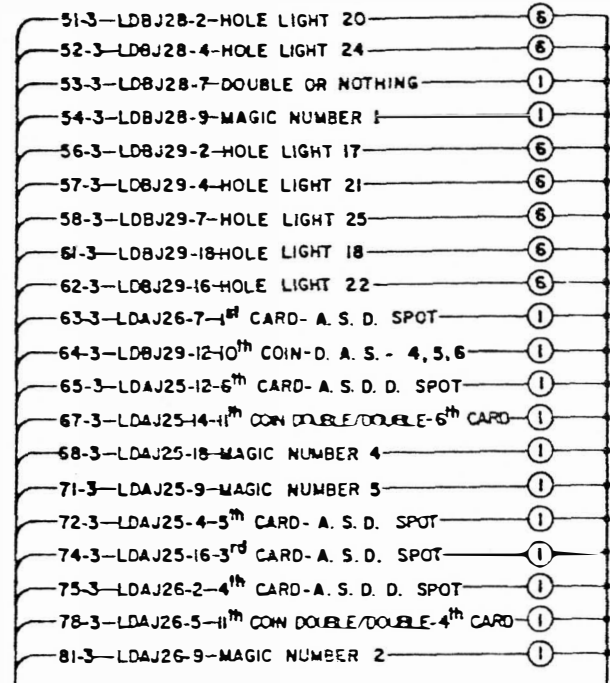
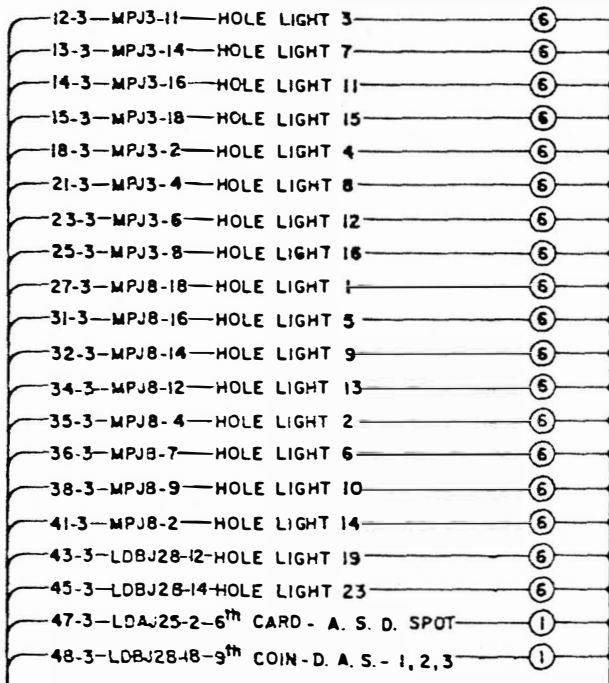

30-2 PSJ17-8
30-3 PSJ17-10

NOTE:
VALUES INSIDE LAMP SYMBOLS INDICATE
THE NUMBER OF LAMPS PER CIRCUIT.

INSERT WIRING DIAGRAM
"B" PHASE

RETURNS

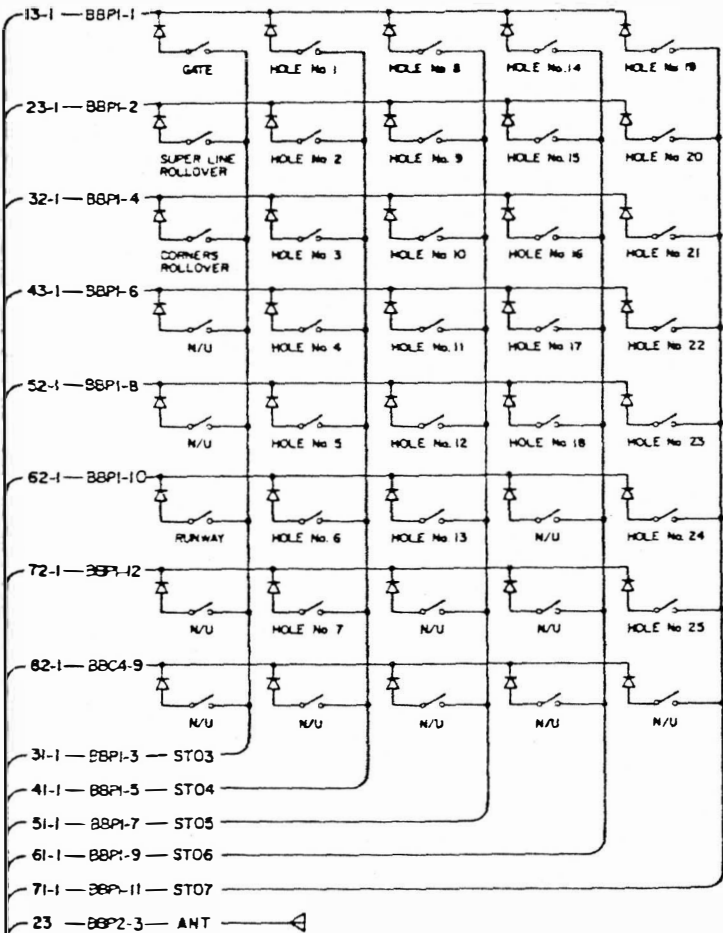

STROBES



TO BACKBOX
(BBP1 BBP2 & BBP3)

FROM BBP-3

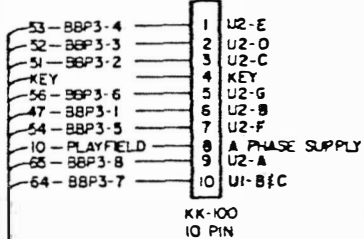

TO
REPLAY
MULTIPLIER
DISPLAY
BOARD
AS 3042-1

NOTE:
ALL DIODES ARE 1N4004

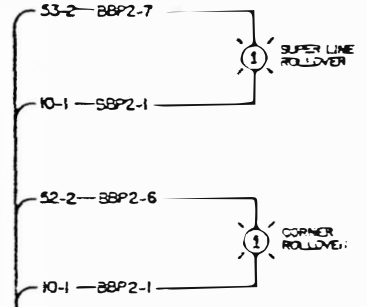
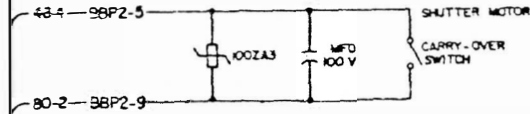
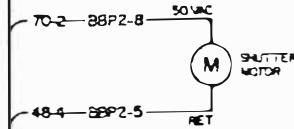

PLAY FIELD WIRING

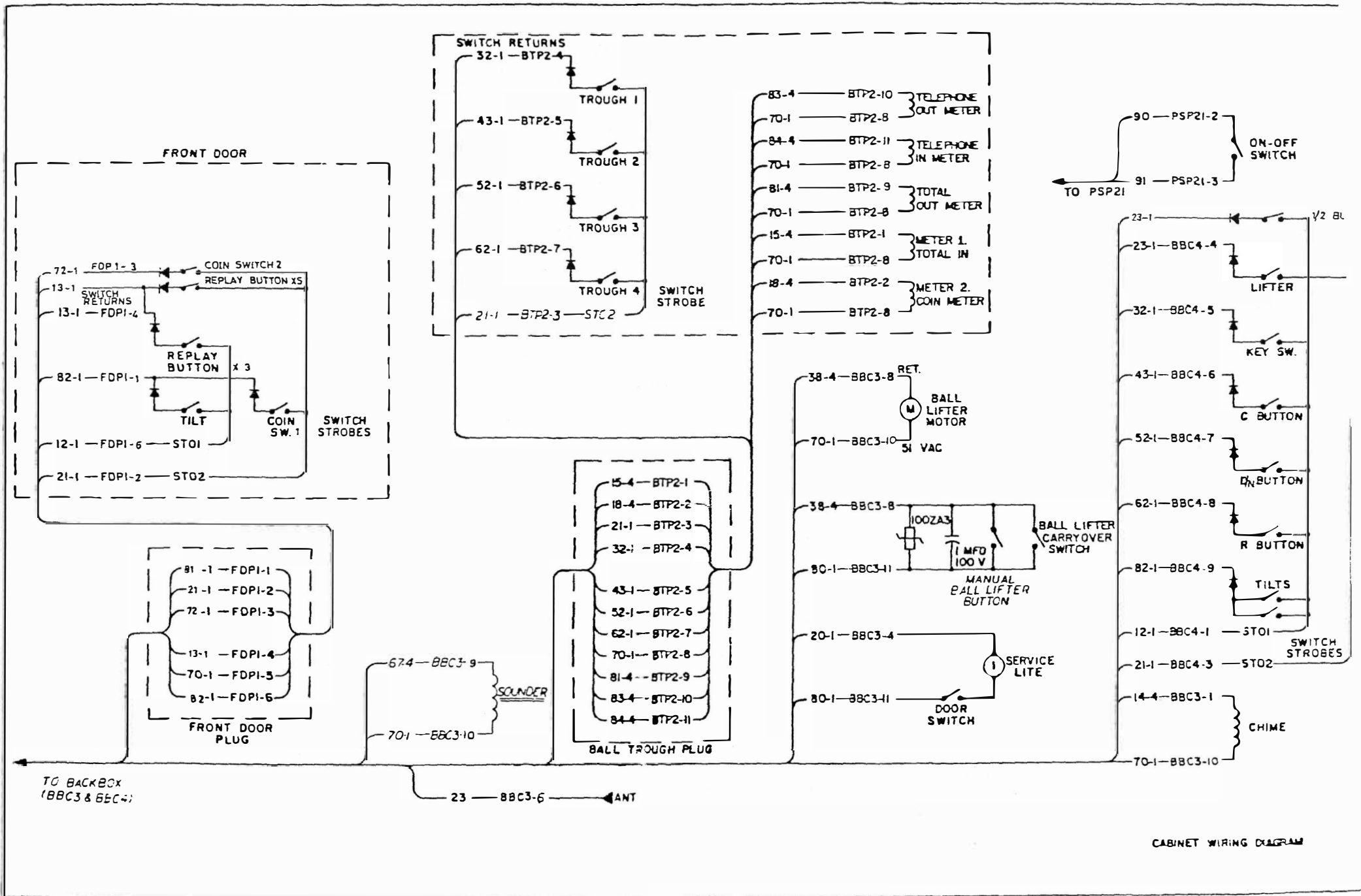

CABINET WIRING DIAGRAM

