

# Bally®

# LOTTA-FUN

(OHIO-FUN-WAY)  
MODEL

## OPERATING INSTRUCTIONS AND PARTS CATALOG

Part Numbers are marked on illustrations  
and a list of miscellaneous parts appears  
on back cover.

**FOR QUICKEST SERVICE  
STATE CORRECT PART NUMBER  
WHEN ORDERING PARTS**

Code	
N.C. ___	Normally closed
N.O. ___	Normally open
M.B.B. ___	Make before break
S.P.D.T. ___	Single pole double throw

*Home of Ballygames and Ballyrides*

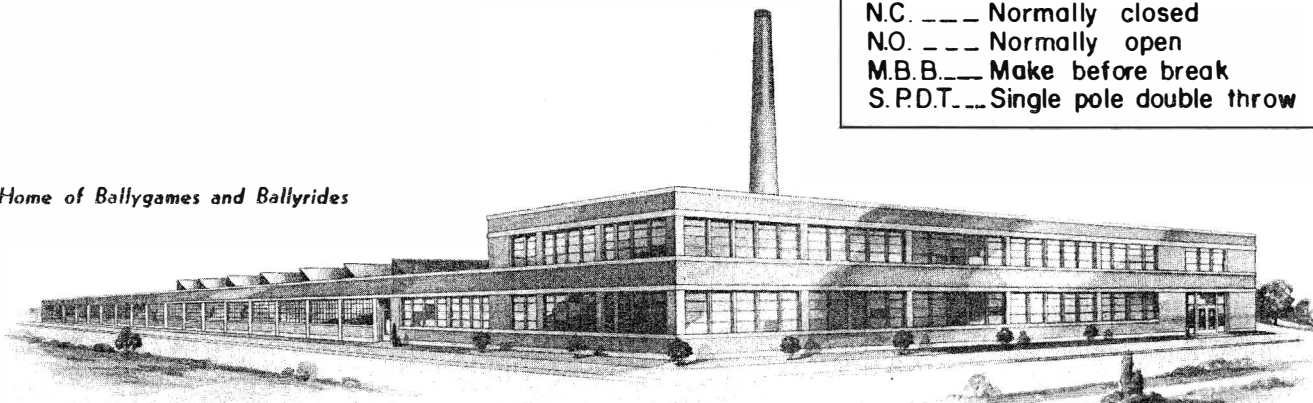



# SELECTION UNIT DISC viewed from BUTTON or WIPER side

6 step unit. Wipers shown in zero or reset position

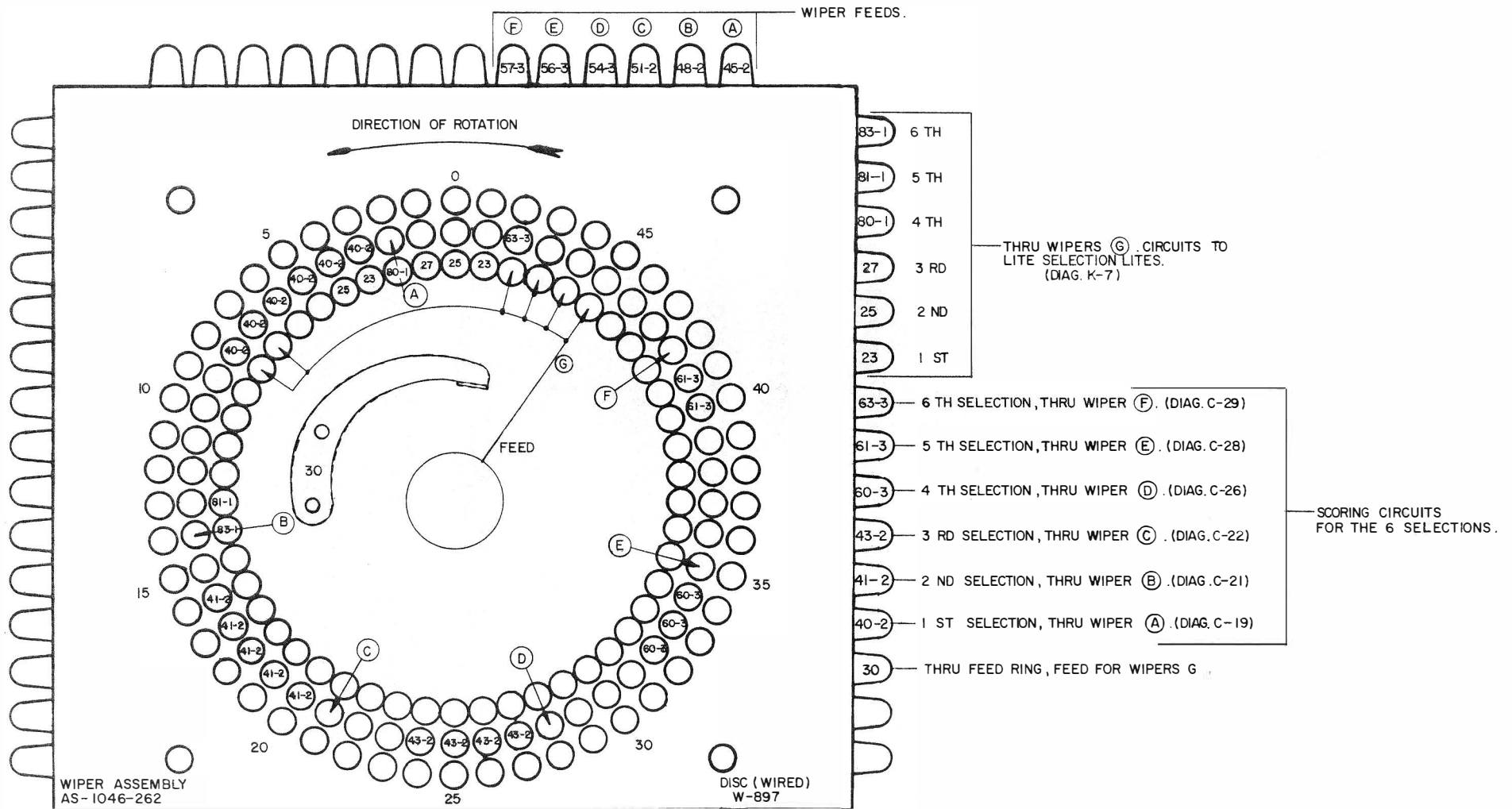

- COMPLETE UNIT.....AS-1022-47
- RESET COIL.....28-R-15
- STEP-UP COIL.....25-GG-7
- STEP-UP PLUNGER.....S-496-100
- STEP-UP ARM.....A-1765-4
- RATCHET & SHAFT.....C-1050-6-39

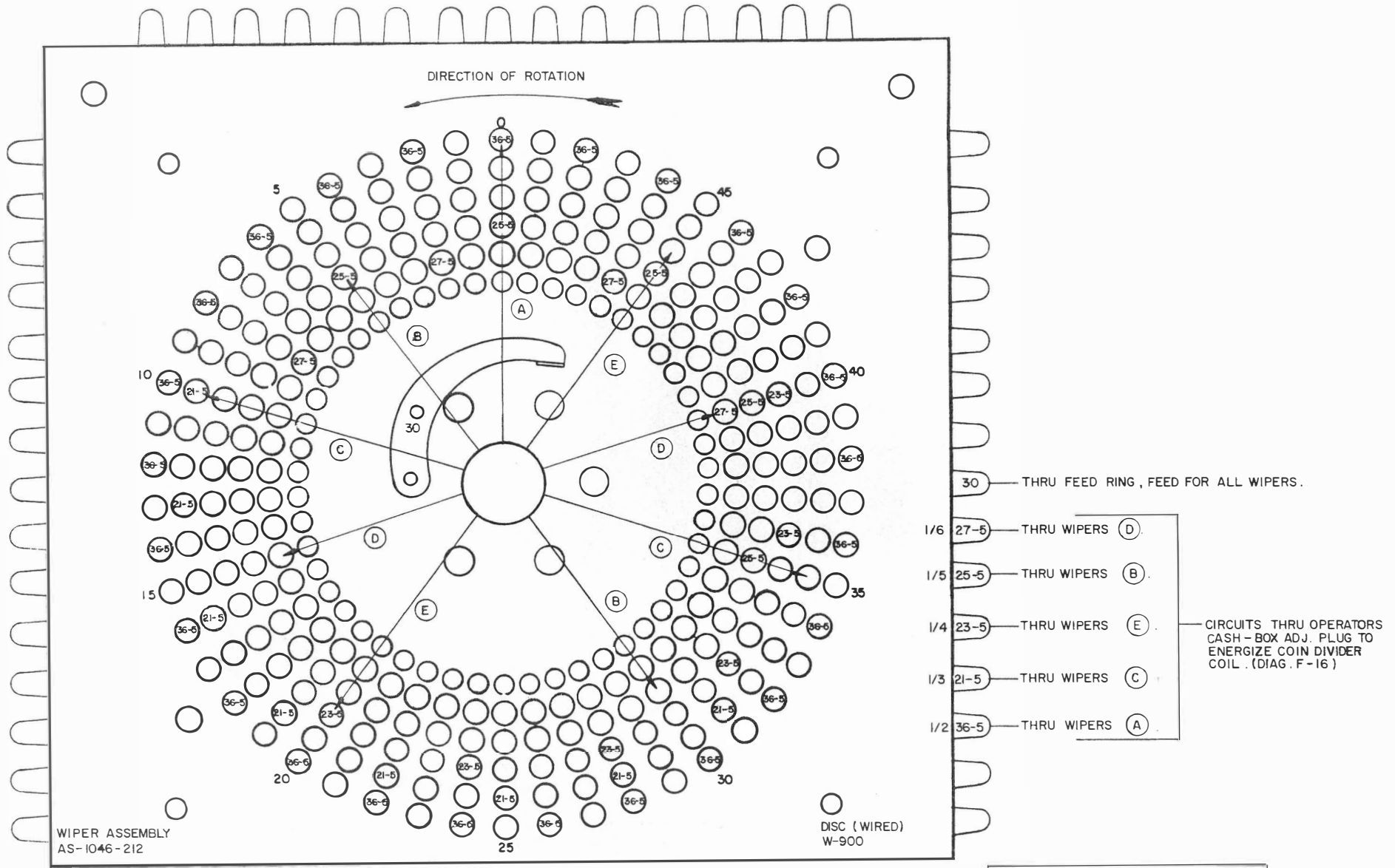

WIPER ASSEMBLY  
AS-1046-212

DISC (WIRED)  
W-900

- 30 — THRU FEED RING, FEED FOR ALL WIPERS.
- 1/6 27-5 — THRU WIPERS (D)
- 1/5 25-5 — THRU WIPERS (B)
- 1/4 23-5 — THRU WIPERS (E)
- 1/3 21-5 — THRU WIPERS (C)
- 1/2 36-5 — THRU WIPERS (A)

CIRCUITS THRU OPERATORS  
CASH - BOX ADJ. PLUG TO  
ENERGIZE COIN DIVIDER  
COIL (DIAG. F-16)

COMPLETE UNIT.....AS-1358-11  
STEP-UP COIL.....E-184-125  
STEP-UP PLUNGER...S-496-100  
STEP-UP ARM.....A-1765-4  
RATCHET & SHAFT...C-1050

# SPOTTING UNIT DISC viewed from BUTTON or WIPER side

Continuous step unit. Wipers shown in zero or reset position

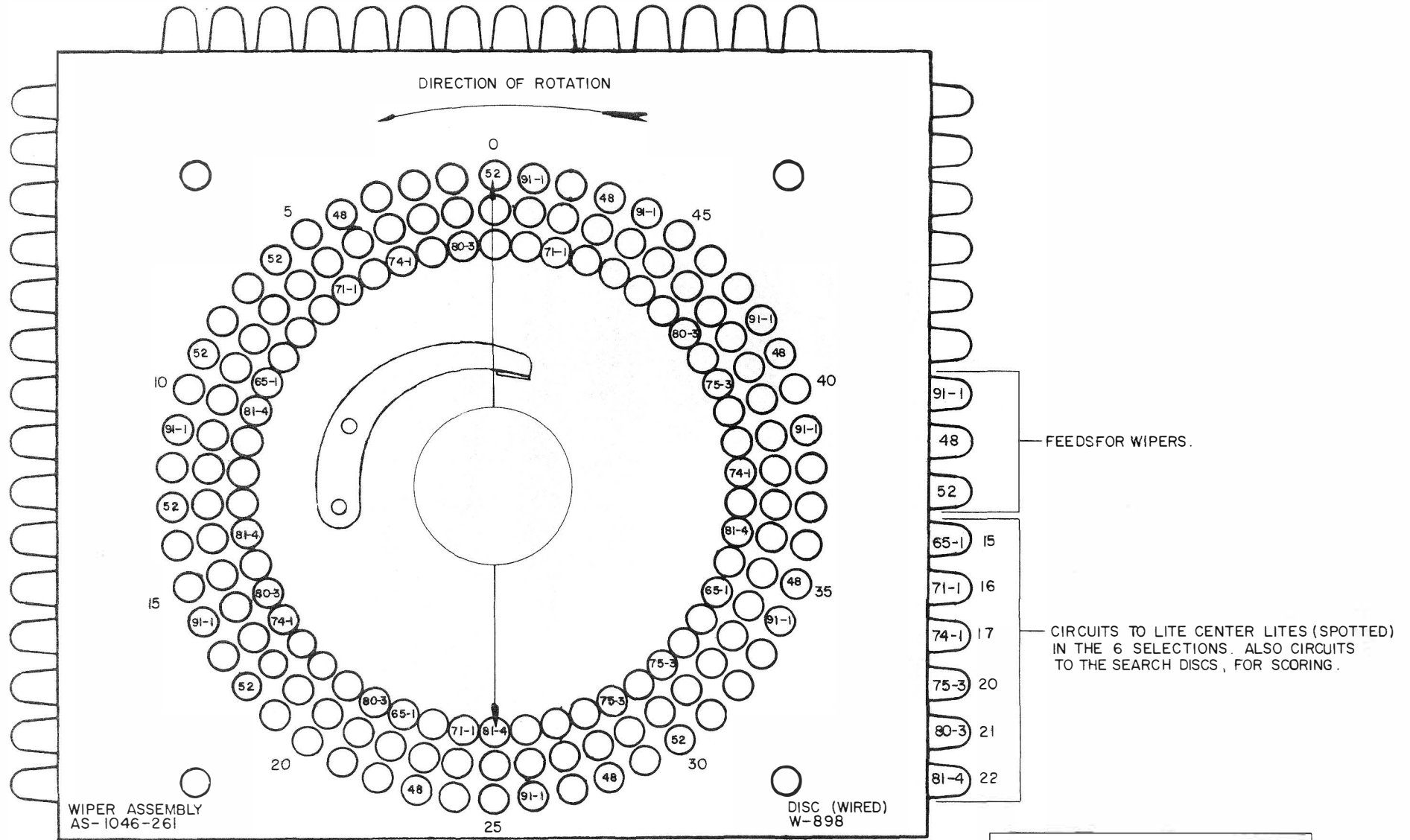

- COMPLETE UNIT.....AS-1358-10
- STEP-UP COIL.....E-184-125
- STEP-UP PLUNGER.....S-496-100
- STEP-UP ARM.....A-1765-4
- RATCHET & SHAFT.....C-1050

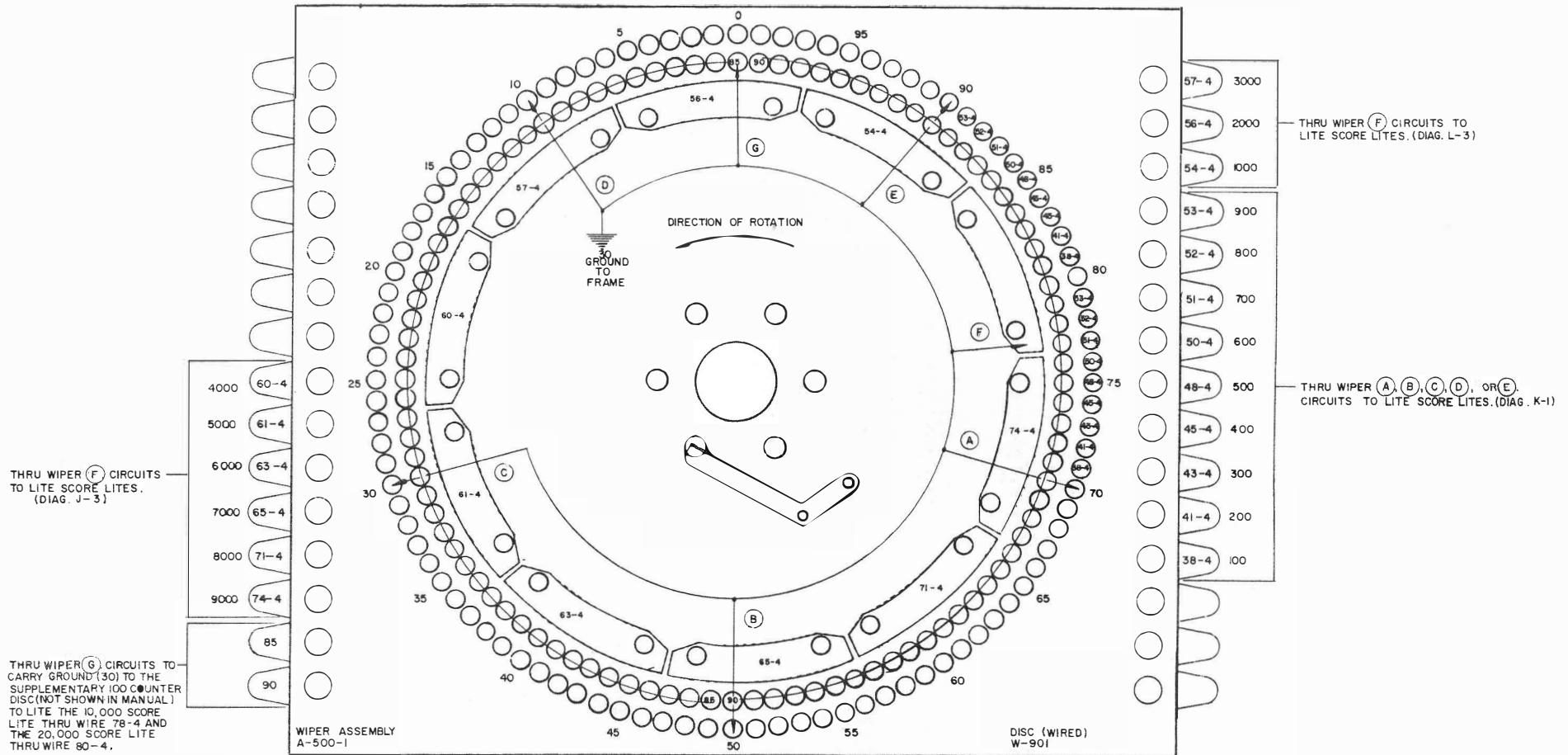

COMPLETE UNIT	AS-405-1
RESET COIL	28-E-15
STEP-UP COIL	26-A-9
STEP-UP ARM	A-279
STEP-UP PLUNGER	S-496
RATCHET & SHAFT	A-716-2
HUB & GEAR ASSEMBLY	A-190

SUPPLEMENTARY 100 COUNTER ASSEMBLY. (PART OF THIS UNIT BUT NOT SHOWN IN MANUAL)	
COMPLETE ASSEMBLY	AS-843-1
DISC (WIRED)	W-901-1
WIPER ASSEMBLY	A-480
GEAR, CAM & SHAFT ASSEMBLY	A-482

# SCORE COUNTER viewed from BUTTON or WIPER side

6 used (see code box at left)

LUG	SCORE COUNTERS # 1-2 -3	SCORE COUNTERS # 4-5-6
100	57-2	45-3
36	31-5	18-5
32	15-4	25-4
28	14-4	23-4
24	13-4	21-4
20	53-2	41-3
4	52-2	27-3
200	60-2	48-3

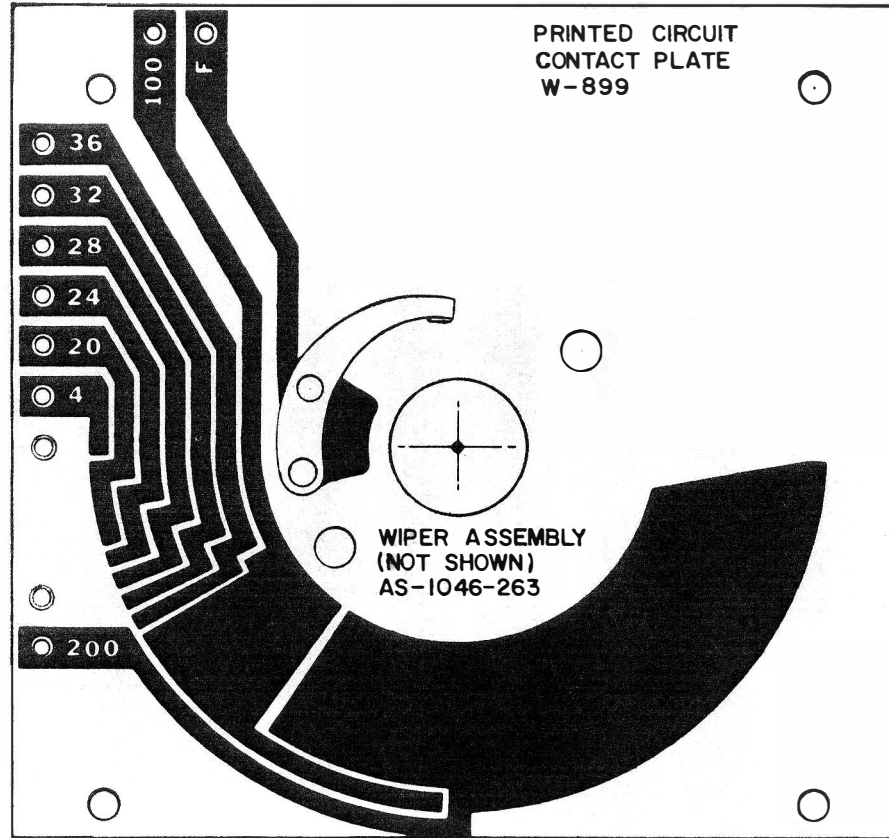

- COMPLETE UNIT\_\_\_\_\_AS-797-45
- RESET COIL\_\_\_\_\_28-R-15
- STEP-UP COIL\_\_\_\_\_25-GG-7
- STEP-UP PLUNGER\_\_\_\_S-496-116
- STEP-UP ARM\_\_\_\_\_A-1765-4
- RATCHET & SHAFT\_\_\_C-100

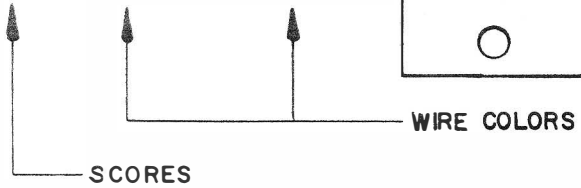

LUG	*1	*2	*3	*4	*5	*6
F	45-2	48-2	51-2	54-3	56-3	57-3







SEARCH POSITIONS						
	WIPER (A) AT POSITION	WIPER (B) ROW 7 SEARCH RELAY #1	WIPER (D) ROW 8 SEARCH RELAY #2	WIPER (A) ROW 9 SEARCH RELAY #3	WIPER (E) ROW 6 SEARCH RELAY #4	WIPER (C) ROW 5 SEARCH RELAY #5
	1					
	2					
	3					
DIAGONAL	4	9	22	17	20	6
	5	3	21	17	19	5
	6	9	8	2	23	5
VERTICAL	7	4	22	11	19	1
	8	10	18	17	12	16
	9	7	21	14	20	25
	10	3	24	15	13	6
	11	6	25	16	1	5
	12	13	20	12	19	23
HORIZONTAL	13	15	14	17	11	2
	14	24	21	18	22	8
	15	3	7	10	4	9
	16					
	17					
	18					
	19					
	20					
DIAGONAL	21	6	20	15	22	10
	22	9	19	15	21	3
	23	6	25	17	8	3
	24	4	20	12	21	23
VERTICAL	25	16	14	15	11	5
	26	24	19	18	22	7
	27	9	13	2	1	10
	28	10	7	5	23	3
	29	1	22	11	21	8
HORIZONTAL	30	2	18	15	12	17
	31	13	19	14	20	25
	32	9	24	16	4	6
	33					
	34					
	35					
	36					
	37					
DIAGONAL	38	3	19	16	21	12
	39	5	22	16	20	15
	40	3	7	17	13	15
	41	25	19	11	20	4
VERTICAL	42	9	10	16	14	2
	43	1	22	18	21	23
	44	5	8	6	24	12
	45	12	23	2	4	15
	46	24	21	14	20	13
HORIZONTAL	47	6	18	16	11	17
	48	8	22	10	19	7
	49	5	1	9	25	3
	50					

SELECTION-3

SELECTION-2

SELECTION-1

ROTATION OF SEARCH DISC WIPERS - FROM 50 TO 1

# SEARCH DISC for Selections 4, 5, 6 viewed from BUTTON or WIPER side

THRU WIPERS A B C D E  
 CIRCUITS FROM PANEL SWITCHES  
 TO ENERGIZE SEARCH RELAYS.  
 (DIAG K-33)

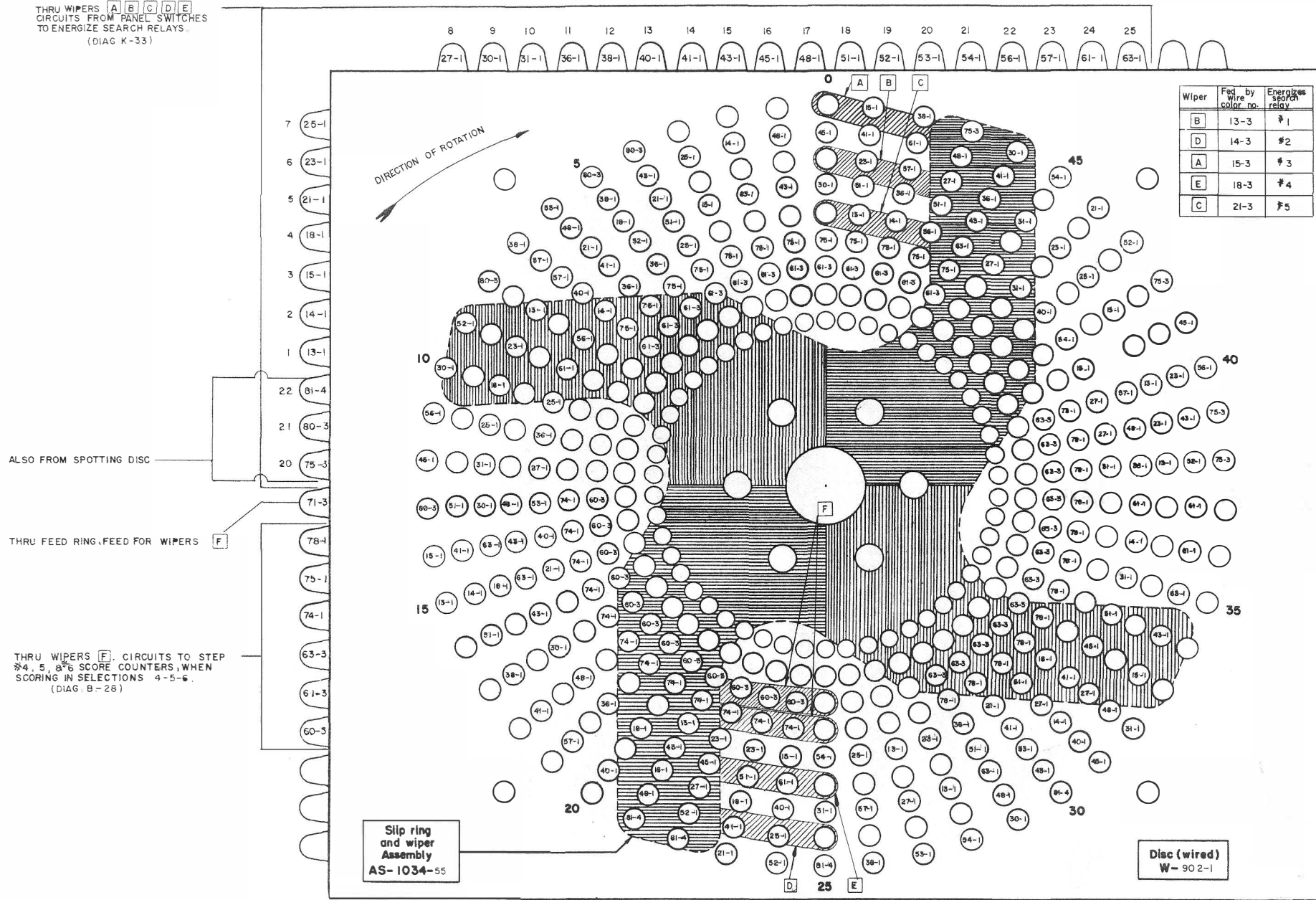

Wiper	Feed wire color no.	Energizes search relay
B	13-3	#1
D	14-3	#2
A	15-3	#3
E	18-3	#4
C	21-3	#5

Slip ring and wiper Assembly  
 AS-1034-55

Disc (wired)  
 W-902-1

ALSO FROM SPOTTING DISC

THRU FEED RING, FEED FOR WIPERS F

THRU WIPERS F, CIRCUITS TO STEP #4, 5, 6 SCORE COUNTERS, WHEN SCORING IN SELECTIONS 4-5-6.  
 (DIAG B-26)

### SEARCH POSITIONS

	WIPER (A) AT POSITION	WIPER (B) ROW 7 SEARCH RELAY *1	WIPER (D) ROW 8 SEARCH RELAY *2	WIPER (A) ROW 9 SEARCH RELAY *3	WIPER (E) ROW 6 SEARCH RELAY *4	WIPER (C) ROW 5 SEARCH RELAY *5	
	1						
	2						
	3						
DIAGONAL	4	5	17	21	18	7	SELECTION-6
	5	4	15	21	14	11	
	6	5	13	20	8	11	
VERTICAL	7	23	17	12	14	2	
	8	1	3	21	16	22	
	9	6	15	19	18	24	
	10	4	25	9	10	7	
	11	7	24	22	2	11	
HORIZONTAL	12	10	18	16	14	8	
	13	9	19	21	12	20	
	14	25	15	3	17	13	
	15	4	6	1	23	5	
	16						
	17						
	18						
	19						
	20						
DIAGONAL	21	4	14	22	15	1	SELECTION-5
	22	8	17	22	18	6	
	23	4	24	5	11	6	
VERTICAL	24	13	14	19	18	3	
	25	10	16	22	9	21	
	26	23	17	12	15	7	
	27	8	2	20	25	1	
	28	1	7	21	3	6	
HORIZONTAL	29	25	15	9	18	11	
	30	20	12	22	19	5	
	31	2	17	16	14	24	
	32	8	23	10	13	4	
	33						
	34						
	35						
	36						
	37						
DIAGONAL	38	1	18	20	17	10	SELECTION-4
	39	6	14	20	15	8	
	40	1	2	22	25	8	
VERTICAL	41	24	18	16	15	4	
	42	3	12	20	9	21	
	43	7	14	19	17	13	
	44	6	23	5	11	10	
	45	10	13	21	4	8	
HORIZONTAL	46	11	17	9	15	25	
	47	5	19	20	16	22	
	48	23	14	12	18	2	
	49	6	7	3	24	1	
	50						

ROTATION OF SEARCH DISC WIPERS—FROM 50 TO 1

# CONTROL UNIT PICTORIAL VIEW

NUMBERS CORRESPOND TO SWITCH CHART ON PAGE 49

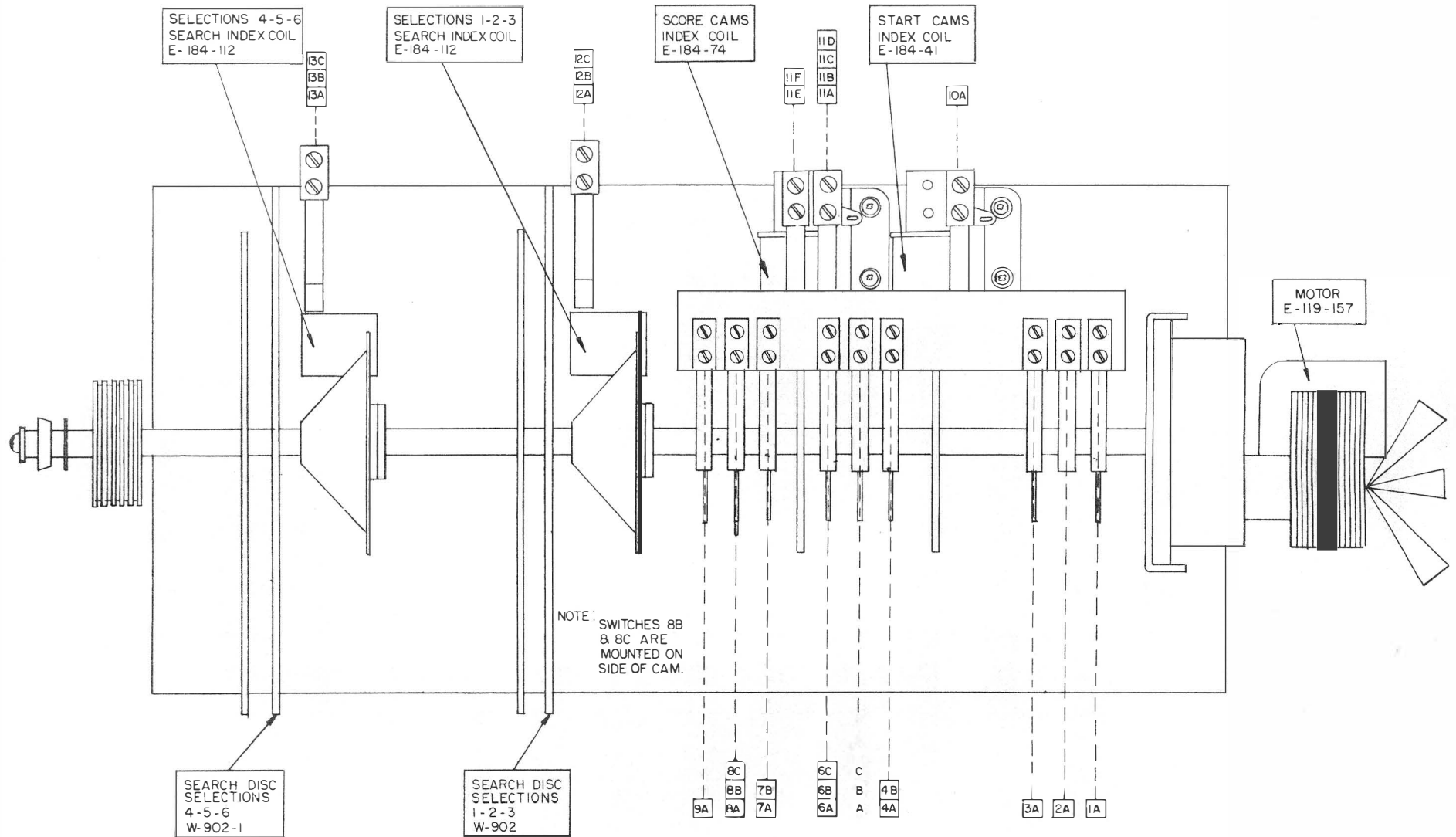

# CONTROL UNIT CAM SWITCH CHART FOR POSITION OF SWITCHES REFER TO PICTORIAL VIEW ON PAGE 48

CAM SWITCH	LOCATION ON DIAGRAM	WIRE No.	WIRE COLORS	FUNCTION OF SWITCHES
1A N.O.	C-14	10-2 13-2	Red Red-Yellow	In series with control unit cam switch #4B, energizes spotting unit step-up coil.
2A PIN SW. N.O.	D-8	93-2 63-2	Gray-Red Brown-Yellow	Pulses timer unit step-up coil after 1st ball is shot.
3A N.O.	C-7	75 83	Orange-White Black-Yellow	Pulses score indicator escapement coil when score reset relay is energized.
4A N.C.	H-6	93-1 30	Gray-Yellow Yellow	Opens start circuit.
4B N.O.	D-14	10-2 36-4	Red Yellow-Brown	In series with control unit cam switch #1A to energize spotting unit step-up coil.
5A N.O.	C-4	51 30	White-Red Yellow	Energizes anti-cheat relay when starting new game (if anti-cheat relay had dropped out).
5B N.O.	F-8	45 63	Green-White Brown-Yellow	Pulses coin unit step-up coil on each coin played (when score indicator is at zero).
5C N.O.	F-7	50-1 63	White Brown-Yellow	Pulses coin unit step-up coil on 1st coin played (when score indicator unit is not at zero).
5D S.P.D.T.	D-6	81 14-5 13-5	Black-Red Red-Green Red-Yellow	Opens start circuit, and completes a circuit to energize tilt relay if coin switch is closed too long.
6A N.O.	D-14	36-4 53-3	Yellow-Brown White-Yellow	Pulses selection unit step-up coil.
6B N.O.	F-5	43 30	Green-Yellow Yellow	Pulses score indicator unit escapement coil when selection unit open at zero switch is closed, and score reset relay is not energized.
6C N.O.	F-17	38-5 30	Yellow-Black Yellow	(Safety circuit) to keep coins from hanging up, pulses coin divider coil on each coin played.
7A N.O.	A-18	75-4 90	Orange-White Gray	Pulses score counter #1, #2, or #3 when a scoring circuit is completed in selection 1-2 or 3.
7B N.O.	A-25	78-2 80	Orange-Black Black	Pulses score counter #4, #5 or #6 when a scoring circuit is completed in selection 4-5 or 6.
8A N.O.	D-15	21-2 23-2	Blue-Red Blue-Yellow	Pulses score indicator unit step-up coil when scoring.
8B VERTICAL N.O.	E-17	27-2 91-2	Blue-Orange Gray-Red	In series with scoring lock-in circuit, when scoring in selections 1-2 or 3.
8C VERTICAL N.O.	E-24	27-2 71-3	Blue-Orange Orange-Red	In series with scoring lock-in circuit, when scoring in selections 4-5 or 6.
9A N.C.	H-16	50 90-1	White Gray	In series with shutter motor switch #1A to complete scoring circuits.

CAM SWITCH	LOCATION ON DIAGRAM	WIRE No.	WIRE COLORS	FUNCTION OF SWITCHES
START CAMS INDEX COIL	A-9	56 70	White-Brown Orange	Energized thru shutter motor cam switch #4C by switch on start relay.
10A N.O.	E-2	10P 20P	Red (Plastic) Blue (Plastic)	Completes a circuit to run control unit motor.
SCORE CAMS INDEX COIL	A-15	21-2 70	Blue-Red Orange	Energized when scoring in any selection, and releases scoring cams.
11A N.O.	H-17	50 27-2	White Blue-Orange	In series with scoring lock-in circuits.
11B N.O.	H-16	50 90-1	White Gray	In series with scoring lock-in circuits.
11C N.C.	B-17	51-3 91-2	White-Red Gray-Red	Opens direct 50 volt circuit to selection 1-2-3 search index coil, coil then held in thru resistor.
11D N.C.	B-24	52-3 71-3	White-Blue Orange-Red	Opens direct 50 volt circuit to selection 4-5-6 search index coil, coil then held in thru resistor.
11E N.O.	E-2	10P 20P	Red (Plastic) Blue (Plastic)	Completes a circuit to run control unit motor.
11F N.C.	E-8	63-2 61-2	Brown-Yellow Brown-Red	Opens timer unit step-up circuit.
SELECTIONS 1-2-3 SEARCH INDEX COIL	B-17	51-3 90	White-Red Gray	Energized when scoring in selections 1-2 or 3.
12A N.C.	H-6	15-5 93-1	Red-White Gray-Yellow	Opens start circuit.
12B N.C.	A-24	80 70	Black Orange	Opens circuit to selection 4-5-6 search index coil.
12C N.O.	H-15	91-2 21-2	Gray-Red Blue-Red	Completes a circuit to energize score cams index coil, also to step score indicator unit.
SELECTIONS 4-5-6 SEARCH INDEX COIL	B-24	52-3 80	White-Blue Black	Energized when scoring in selections 4-5 or 6.
13A N.C.	G-6	15-5 57	Red-White White-Orange	Opens start circuit.
13B N.C.	A-17	90 70	Gray Orange	Opens circuit to selection 1-2-3 search index coil.
13C N.O.	G-15	71-3 21-2	Orange-Red Blue-Red	Completes a circuit to energize score cams index coil, also to step score indicator unit.

# SHUTTER MOTOR PICTORIAL VIEW

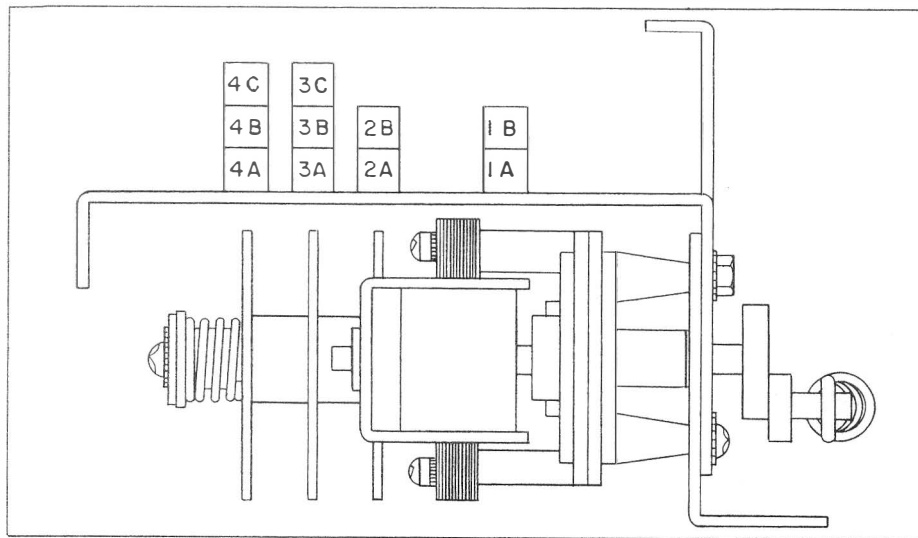

## SHUTTER MOTOR CAM SWITCH CHART FOR POSITION OF SWITCHES SEE PICTORIAL VIEW

CAM SWITCH	LOCATION ON DIAGRAM	WIRE No.	WIRE COLORS	FUNCTION OF SWITCHES
1A	N.C.	H-16	90-1 30 Gray Yellow	Opens scoring circuits when starting new game.
1B	N.O.	C-9	90-2 30 Black Yellow	Carry-over circuit for shutter motor.
2A	N.O.	F-10	98 30 Gray-Black Yellow	Energizes the ball gate relay when starting new game.
2B	N.O.	H-12	85 30 Black-White Yellow	Resets the (6) score counter units, selection unit, timer unit, and energizes the tilt reset coil when starting new game.
3A	N.O.	F-9	38-2 61 Yellow-Black Brown-Red	In series with cam #3C circuit. Also in series with circuit to close shutter when 1st ball is shot.
3B	N.C.	I-9	91-1 30 Gray-Red Yellow	Opens circuit to spotted no. lites when starting new game.
3C	N.O.	D-9	61 80-2 Brown-Red Black	In series circuit to close shutter if game is tilted before 1st ball is shot.
4A	N.O.	C-7	78 81 Orange-Black Black-Red	Circuit to energize start relay thru score indicator zero switch.
4B	N.C.	F-8	60-1 93-2 Brown Gray-Yellow	Opens timer unit step-up circuit when starting new game.
4C	S.P.D.T.	B-9	80-2 54 56 Black White-Green White-Brown	Directs circuit to open shutter, and energize start cams index coil when starting new game.

# SHUTTER MOTOR

(MOTOR PART NO. E-119-99)

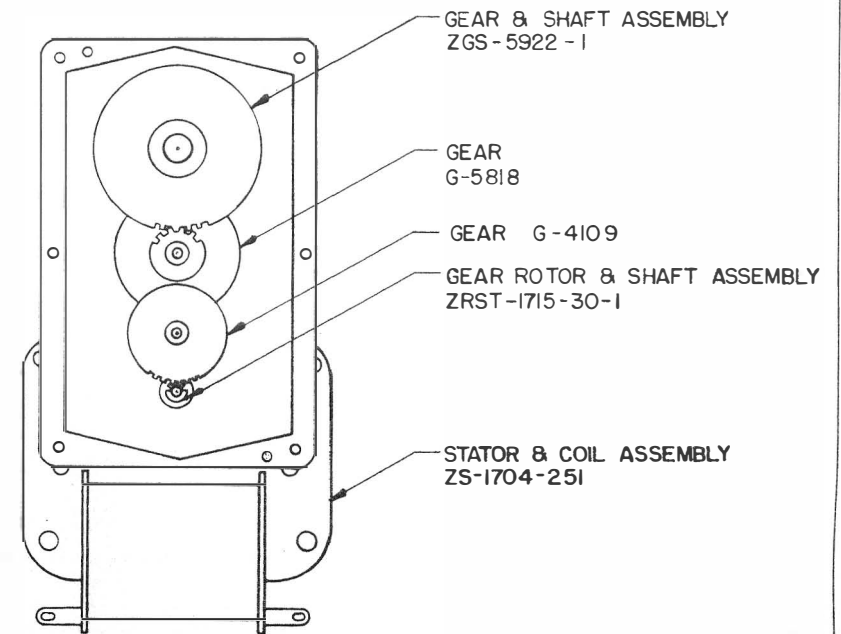

NOTE:

WHEN ORDERING GEARS FOR SHUTTER MOTOR,  
REFER TO PART NUMBERS SHOWN ABOVE.

### 3 RELAYS BANK PICTORIAL VIEW

NUMBERS CORRESPOND TO SWITCH CHART BELOW

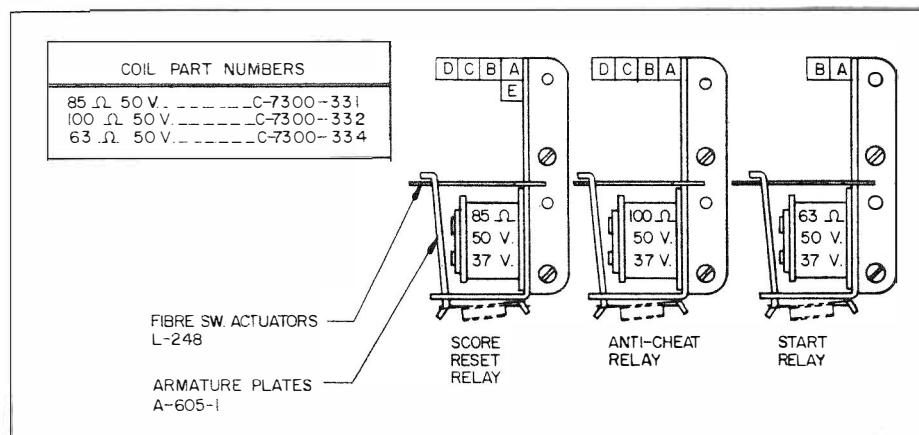

### 3 RELAYS BANK SWITCH CHART

FOR POSITION OF SWITCHES REFER TO PICTORIAL VIEW ABOVE

RELAY SWITCH	LOCATION ON DIAGRAM	WIRE No.	WIRE COLORS	FUNCTION OF SWITCHES	
SCORE RESET RELAY COIL	A-8	75 70	Orange-White Orange	Energized thru score indicator zero switch when anti-cheat relay drops out.	
A S.P.D.T.	D-7	91 93 83	Gray-Red Gray-Yellow Black-Yellow	Opens circuit to pulse score indicator escapement coil thru control unit cam switch #6B, and completes circuit to pulse score indicator escapement coil thru cam switch #3A.	
B	N.O.	74 75	Orange-Green Orange-White	Completes lock-in circuit for this relay.	
C	N.O.	C-2	10P 20P	Red (Plastic) Blue (Plastic)	Completes a circuit to run control unit motor.
D	N.C.	C-8	59 61-2	White-Yellow Brown-Red	Opens timer unit step-up circuit.
E	N.C.	B-6	81 98-3	Black-Red Gray-Black	Opens start circuit.
ANTI-CHEAT RELAY COIL	A-5	51 70	White-Red Orange	Energized by control unit cam switch #5A. This relay stays energized whenever game is in operation.	
A	N.O.	B-5	51 30	White-Red Yellow	Completes lock-in circuit for this relay.
B	N.O.	L-6	14 15	Red-Green Red-White	Opens 17 volt circuit when this relay drops out.
C	N.C.	E-8	74 75	Orange-Green Orange-White	Completes circuit to energize replay reset relay when this relay drops out.
D	N.C.	L-4	31-4 18	Yellow-Red Red-Black	Lites tilt lite when this relay drops out.
START RELAY COIL	A-6	98-3 70	Gray-Black Orange	Energized thru control unit cam switch #5 each time a coin is played. Also thru score indicator zero switch and shutter motor switch #4A.	
A	N.O.	D-6	57 81	White-Orange Black-Red	Completes lock-in circuit for this relay.
B	N.O.	C-9	54 30	White-Green Yellow	Thru shutter motor cam switch #4C, completes circuit to open shutter, and when shutter is open completes circuit to energize start cams index coil.

### MISCELLANEOUS RELAYS SWITCH CHART

RELAY SWITCH	LOCATION ON DIAGRAM	WIRE No.	WIRE COLORS	FUNCTION OF SWITCHES	
TILT RELAY COIL	A-5	13-5 70	Red-Yellow Orange	Energized by any tilt switch or the plumb-bob tilt. Also thru control unit cam switch #5d if coin switch is closed too long (anti-cheat coin switch circuit).	
A	S.P.D.T.	H-8	60-1 30 38-2	Brown Yellow Yellow-Black	Opens timer unit step-up circuit, and completes a circuit to close shutter if game is tilted before 1st ball is shot.
B	N.C.	B-5	13-5 13-5	Red-Yellow Red-Yellow	Opens circuit to coil.
C	N.C.	M-6	10 15	Red Red-White	Opens 17 volt circuit.
D	N.O.	L-4	18 31-4	Red-Black Yellow-Red	Completes a circuit to lite tilt lite.
E	N.C.	D-1	10P 50P	Red (Plastic) White(Plastic)	Opens circuit to control unit motor.
TILT RESET COIL	A-11	85 70	Black-White Orange	Energized by shutter motor cam switch #2B, when starting new game.	
BALL GATE RELAY COIL	A-10	98 70	Gray-Black Orange	Energized by shutter motor cam switch #2A, when starting new game.	
A	N.C.	G-9	61 30	Brown-Red Yellow	Completes a circuit to close shutter when relay drops out (1st ball is shot).
B	N.O.	E-10	71 98	Orange-Red Gray-Black	Completes lock-in circuit for this relay until 1st ball is shot.



## **NEW ANTI-CHEAT COIN SWITCH CIRCUIT**

The coin switch gives a very short pulse, when operated by a coin. With this new circuit, the game will tilt if the pulse is not as short as from a coin, so that operating the coin switch with wire, strings, etc., usually results in a tilt.

The circuit is completed thru control unit cam switch #5D (on wiring diagram at D-6).

# MOTOR ASSEMBLY (Part No. E-119-157)

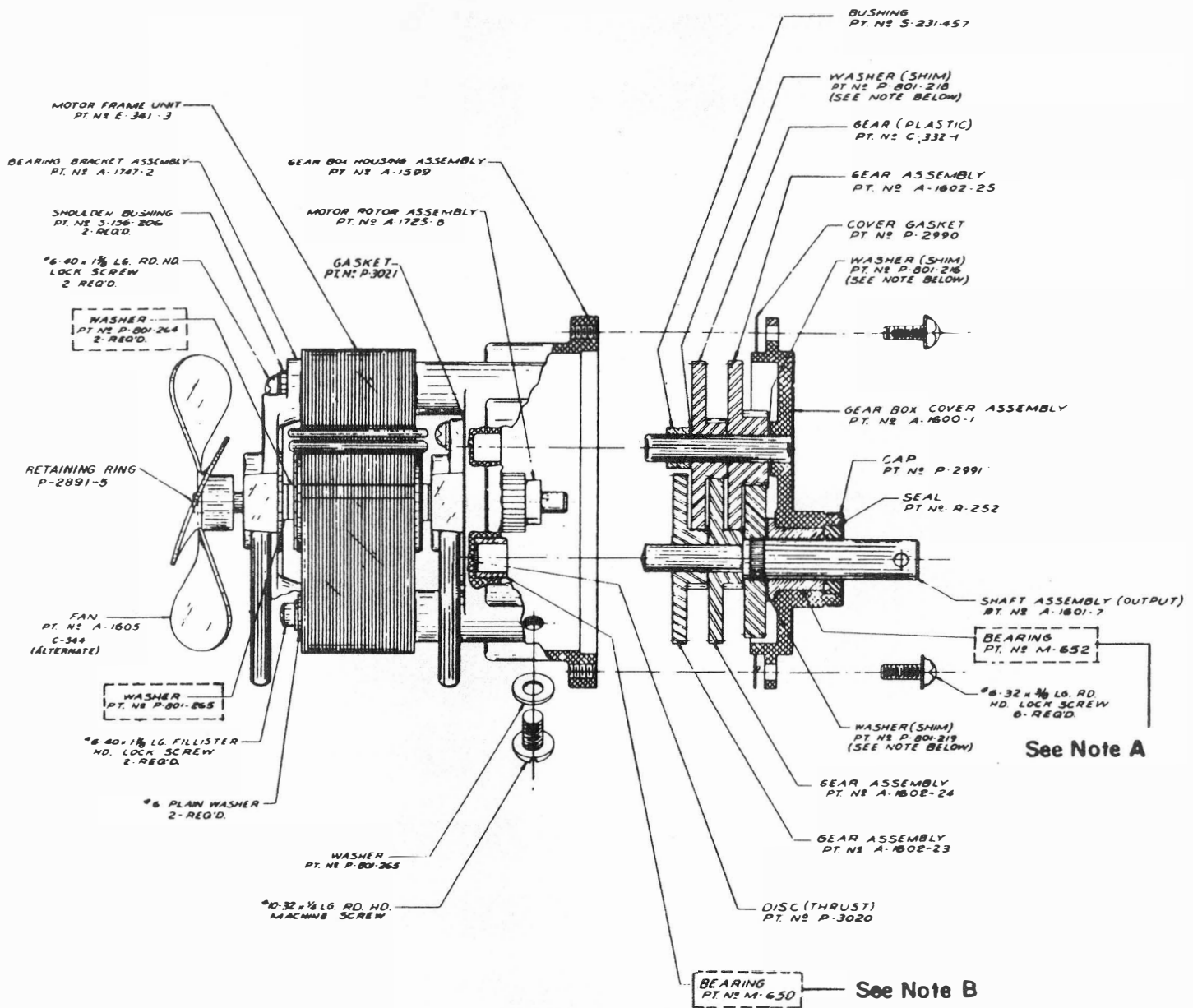

## NOTE

IN ORDER TO MAINTAIN PROPER CLEARANCES BETWEEN GEARS IT IS MOST IMPORTANT THAT WHEN REASSEMBLING GEAR TRAIN:

1. SHIMS BE REPLACED IN THEIR RESPECTIVE LOCATIONS.
2. SAME NUMBER OF SHIMS BE REPLACED IN EACH RESPECTIVE LOCATION.

CHECK PART NUMBER ON BEAR BEFORE ORDERING BEAR

**NOTE A:** Bearing M-652 is part of Gear Box Cover Assembly A-1600-1 and cannot be ordered separately.

**NOTE B:** Bearing M-650 is part of Gear Box Housing Assembly A-1599 and cannot be ordered separately.

# NOTES

# NOTES

# MISCELLANEOUS PARTS

## Back Cabinet Assembly:

Part No.	Name of Part
G-303	Back glass—Fun Way
G-303-1	Back glass—Lotta-Fun
M-281-14	Lock and keys (2) Keyed alike

## Back Door Assembly:

M-281-22	Lock and keys
P-758-17	Lock cam
E-300-140	Search Relay bank assembly
SW-100-25	Switch (tilt)
E-122-19	Transformer

## Front Cabinet Assembly:

M-168-15	Ball
AS-187-18	Ball shooter assembly
A-1540-3	Ball shooter housing
A-100-7	Ball shooter rod
SP-200-24	Ball shooter spring (long)
SP-243	Ball shooter spring (short)
HR-108-3	Ball shooter tip
P-711-1	Cigarette holder
CA-1016-2	Front moulding only
M-281-22	Lock and keys—side door
P-4052	Leg
M-106-1	Leg bolt
M-163-4	Leg adjuster
CA-1016-3	Side door only
E-108-57	Toggle switch

## Front Door Assembly:

Part No.	Name of Part
A-1538-3	Armature plate (AS-277-56)
E-101-45	Coil—coin lockout
AS-277-56	Coin switch assembly 5c and 10c
CA-567-88	Front door only—Fun Way
CA-567-89	Front door only—Lotta-Fun
AS-1971	Front door assembly complete— Fun Way
AS-1971-1	Front door assembly complete— Lotta Fun
A-254-33	Hinge and bracket
M-281-6	Lock and keys
P-4005	Lock cam
E-108-32	Micro switch 5 and 10¢
A-1729-4	Push button—Replay
SW-100-157	Push button switch
P-2768-5	Ring for A-1729-4 button
P-2768-7	Ring for M-281-6 lock
M-280-15	Slug rejector 5¢
M-280-16	Slug rejector 10¢

## Panel Assembly:

AS-1315	Ball Gate and Switch Assembly
C-326-9	Light Shield post
R-115-4	Rebound Rubber
M-170	Rebound spring—Double post
R-243	Rubber ring for yellow post
R-243-2	Rubber ring for red post

Bally pin game lubricant now available in one half-pint  
(8 Oz.) containers with plastic spout and screw cap.