

GAME 1107
SPRING 77

Bally

MISS ★ AMERICA

SERVICE MANUAL & PARTS GUIDE

Supreme



Bally

MANUFACTURING CORPORATION

2640 Belmont Avenue · Chicago, Illinois, 60618, U.S.A.

TELEPHONE (312) 267-6060/TELEX NO. 253076/CABLE ADDRESS: BALFAN

CONTENTS



DESCRIPTION	PAGE NO.
BACK DOOR ASSEMBLY	2
BACK CABINET INSERT	3
FRONT CABINET ASSEMBLY	4
PLAYFIELD PANEL	5
MAGIC LINE UNIT	6
CONTROL UNIT ASSEMBLY	7
CONTROL UNIT FUNCTION CHART	8 & 9
C.U. SEARCH DISC & WIPER	10
CONTROL DISC ASSEMBLY	11
PROGRAM DISC ASSEMBLY	12
MIXER & SPOTTING UNIT	13
MIXER FUNCTION CHART	14
12 TRIP BANK	15-18
6 RELAY BANK	19-20
3 RELAY BANK	21
5 SEARCH BANK	22
SELECTION FEATURE UNIT	23
REPLAY COUNTERS	24
SCORE UNIT DISCS	25-26
RED LETTER UNIT	27
TIMER UNIT	28
EXTRA BALL UNIT	29
PANEL SHUTTER ASSEMBLIES & SW'S.	30-32
FRONT CABINET SW. ASSEMBLIES	33-34
MOTOR PARTS GUIDE	35
MYSTIC LINES MOTOR UNIT DISCS.	36
PARTS GUIDE	37
MAINTENANCE & SERVICE SUGGESTIONS	38

BACK DOOR ASSY. & PAGE INDEX

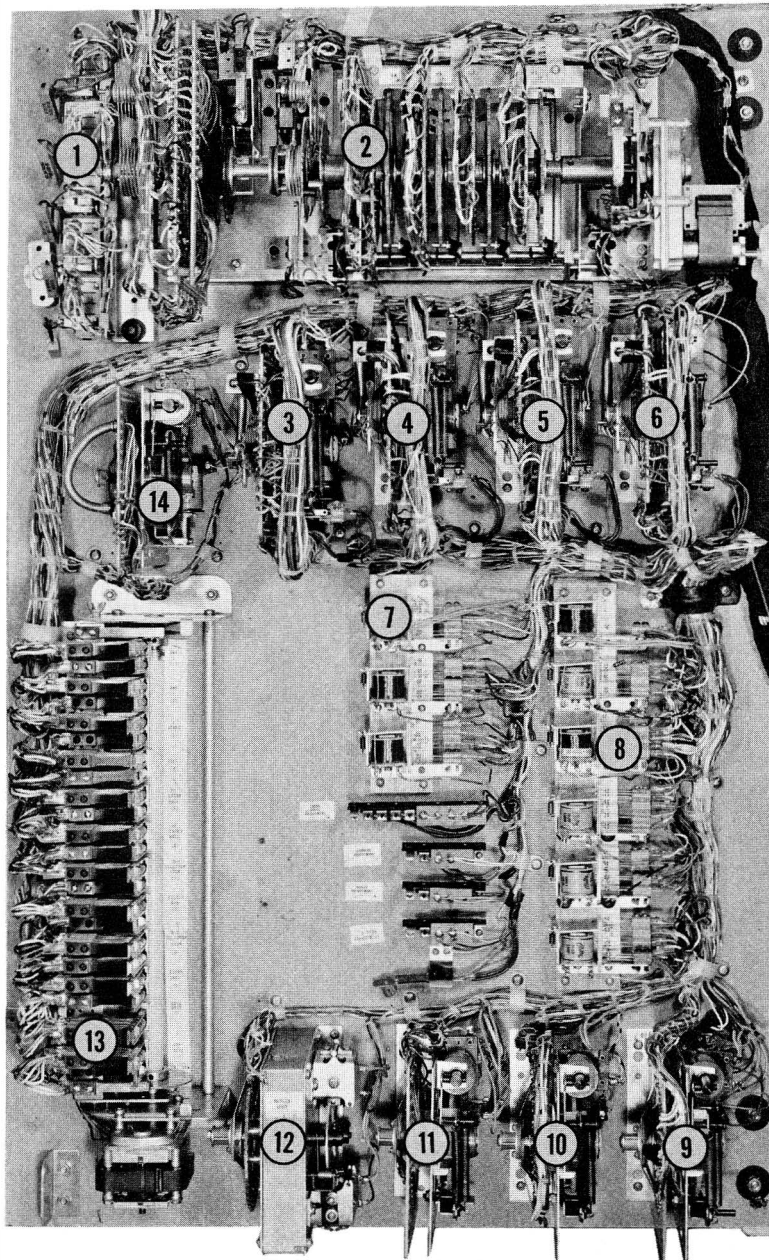

Index No.	Part No.	Description	Page No.
1	E-300-882	Search Relay Bank . . .	22
2	AS-1020-65	Mixer Unit Assembly .	13
3	AS-1022-159	Red Score Unit . . .	26
4	AS-1022-152	Yellow Score Unit . .	25
5	AS-1022-152	Green Score Unit . . .	25
6	AS-1022-152	White Score Unit . . .	25
7	E-300-884	(3) Relay Bank	21
8	E-300-883	(6) Relay Bank	19 20
9	AS-827-655	Selection Feature Unit	23
10	AS-1148-36	Extra Ball Unit	29
11	AS-1110-54	Timer Unit	28
12	AS-873-55	Reflex Unit	34
13	AS-2409-40	(12) Trip Bank	17
14	AS-1022-157	Red Letter Unit	27

ALWAYS GIVE MODEL AND PART NO. WHEN ORDERING SERVICE PARTS

BACK CABINET INSERT & PAGE INDEX

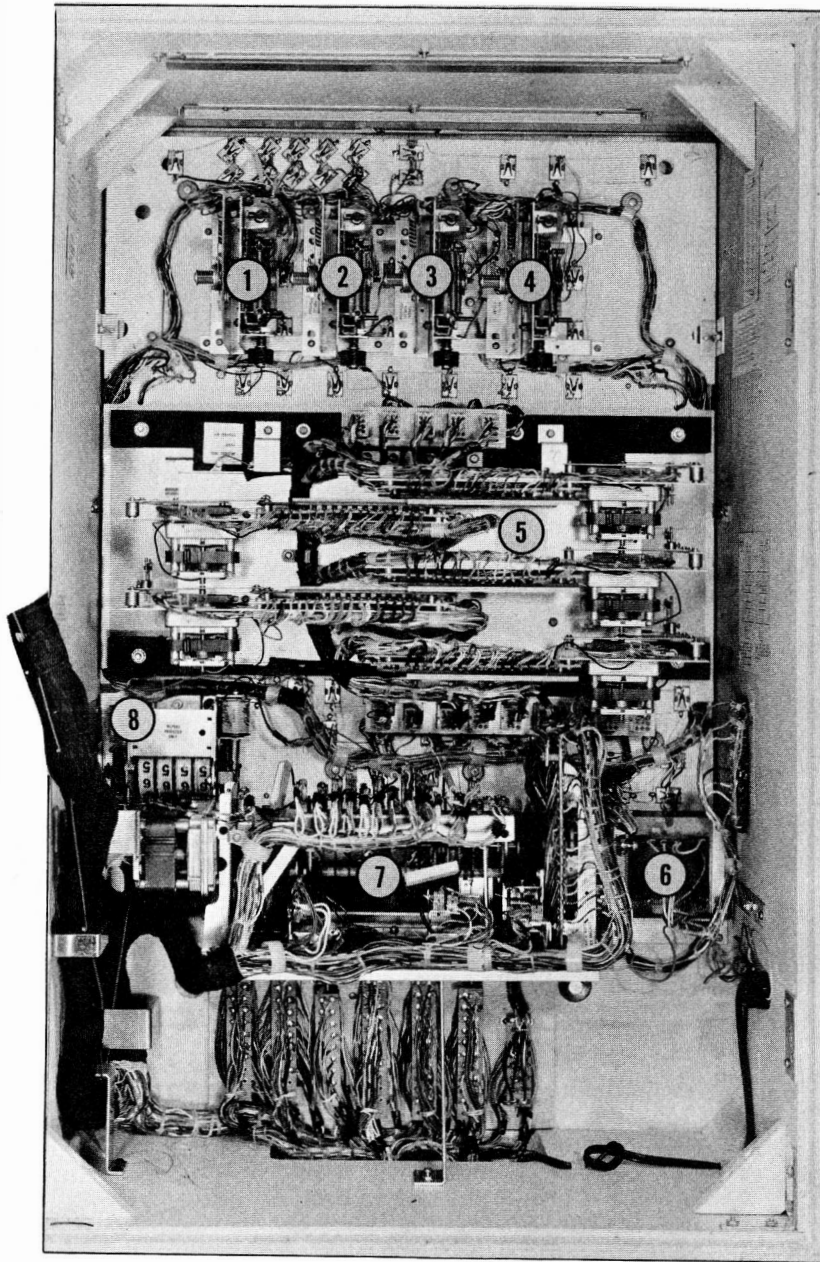

INSERT ASSEMBLY

Index No.	Part No.	Description	Page No.
1	AS-797-418	Red Replay Counter . .	24
2	AS-797-418	Yellow Replay Counter .	24
3	AS-797-418	Green Replay Counter .	24
4	AS-797-418	White Replay Counter .	24
5	AS-2831-1	Magic Lines Unit Assy. .	6 36
6	E-122-103	Transformer	
7	AS-798-124	Control Unit Assembly .	7 9
8	AS-473-54	Free Play Counter . . .	34

ALWAYS GIVE MODEL AND PART NO. WHEN ORDERING SERVICE PARTS

FRONT CABINET ASSY. & PAGE INDEX

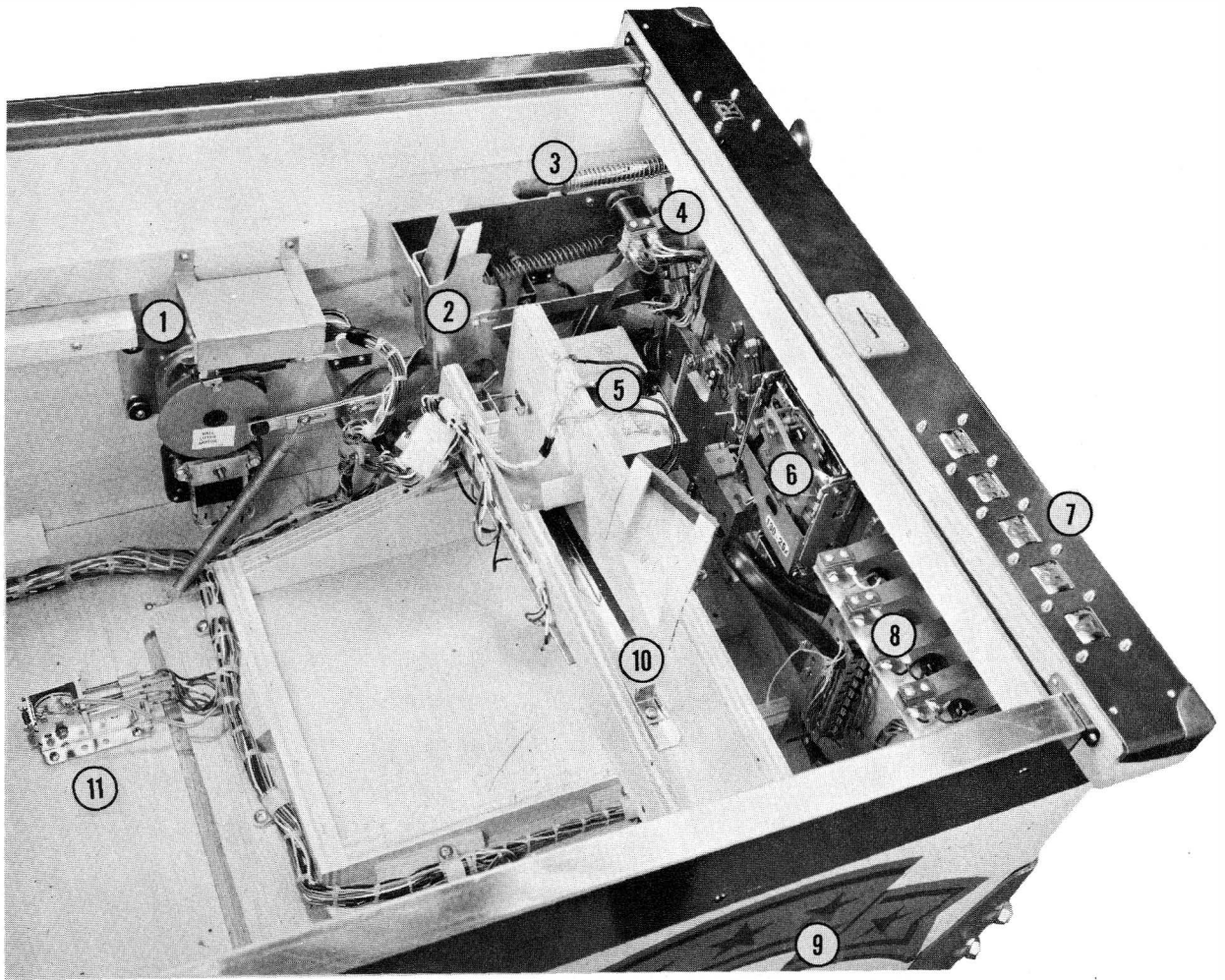

FRONT CABINET

Index No.	Part No.	Description	Page No.
1	AS-1139-32	Ball Lifter Motor Assy.	32
2	AS-186-11	Ball Lifter Assy. . . .	
3	AS-187-20	Ball Shooter Assy. . . .	
4	AS-982-1167	"R" Button Sw. & Brkt. Assembly	33
5	E-130-10	Coin, Key Meter	34
6	AS-277-105	Coin Sw. & Rej. Mount Assembly	
7	AS-1305-63	Front Molding Assy. . .	37
8	AS-982-1075	A, B, C, D, E Button Sw. & Bracket Assy. . . .	33
9	M-281-54	Lock	
10	AS-1145-56	Ball Trough & Sw. Assy.	32
11	AS-2659-448	G-Relay Coil & Sw. Assy.	31

ALWAYS GIVE MODEL AND PART NO. WHEN ORDERING SERVICE PARTS

PLAYFIELD PANEL & PAGE INDEX

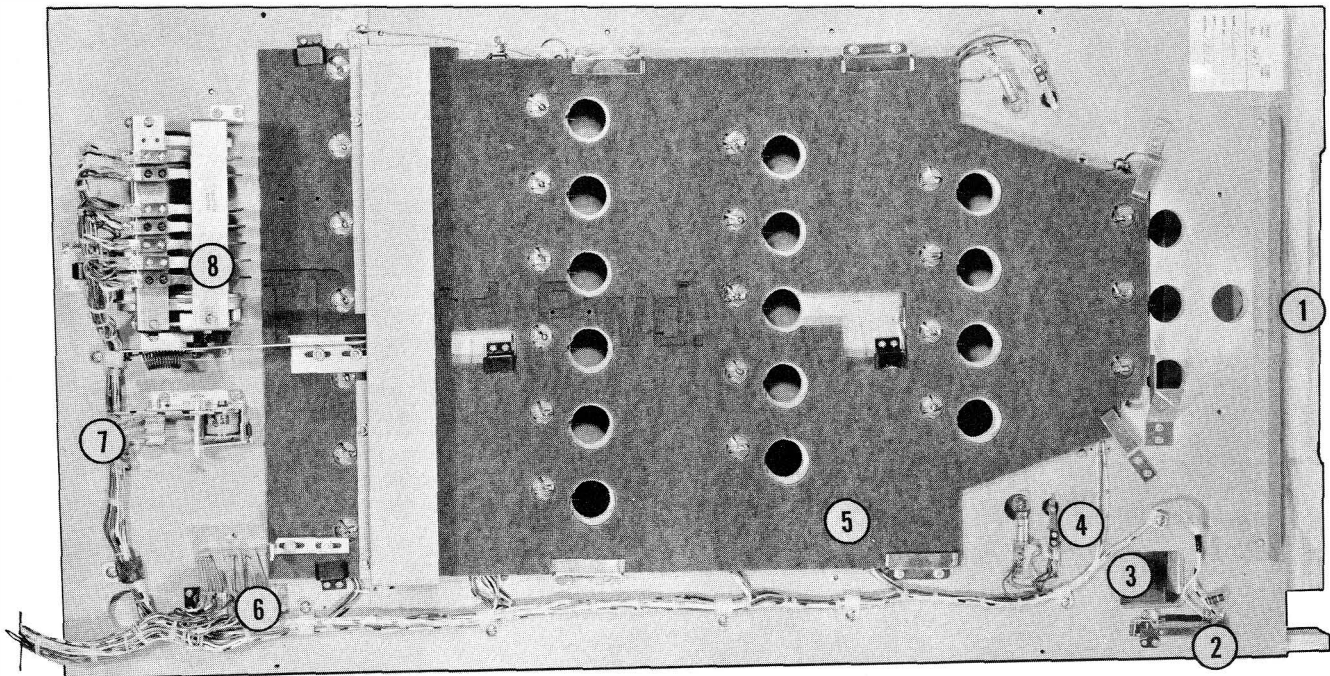

PLAYFIELD PANEL

Index No.	Part No.	Description	Page No.
1	CA-1100-9	Arch Bottom	
2	ASW-A1-30	Ball Runway Sw.	32
3	C-153	Red Plastic Ball Cover	
4	ASW-A10-16	Rollover Sw.	32
5	AS-1433-16	Shutter Assy.	
6	AS-982-1153	Panel Switches	31
7	AS-2659-266	Lifter Start Relay	31
8	AS-232-96	Shutter Motor Assy.	3031

ALWAYS GIVE MOOEL AND PART NO. WHEN ORDERING SERVICE PARTS

MAGIC LINE UNIT & FUNCTION CHART

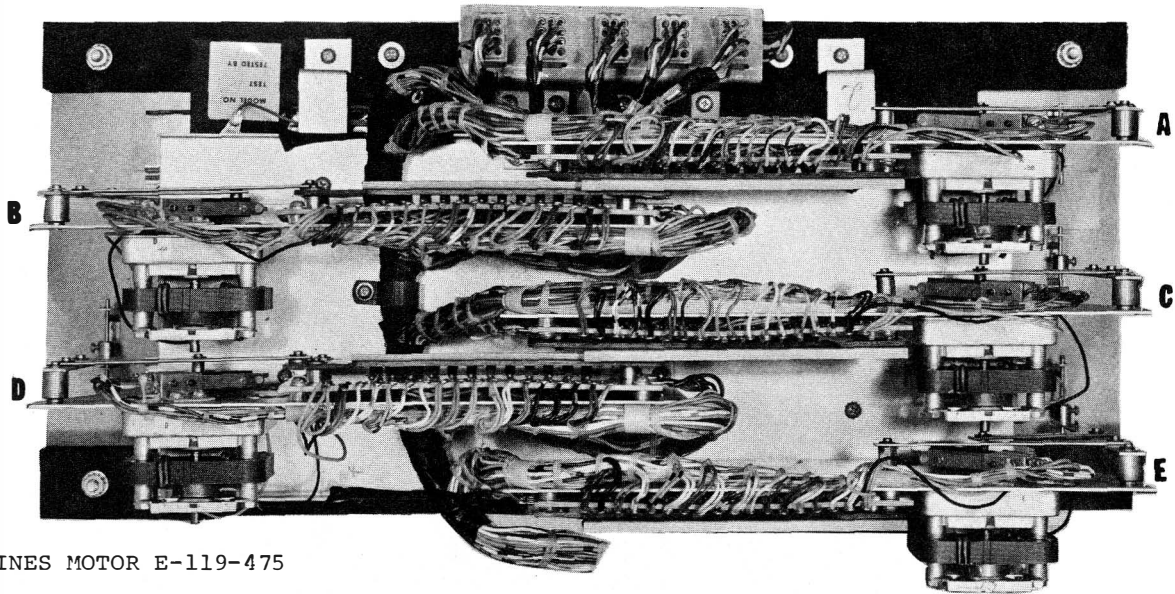

MAGIC LINES MOTOR E-119-475

CONTACT PLATES WIRED PART NO. W-1173-1

WIPER ASSEMBLIES

A, C, E, PART NO. A-1371-153

B, D, PART NO. A-1371-154

FOR CONTACT WIPER PLATE WIRING SEE PAGE 36.

Switch/Coil	Part No.	Location on Diagram	Wire No.	Wire Color	Function
"A" Motor	E-119-475	A-34	70 10-11	Orange Red	Energizes motor
Carryover A. N. O.	ASW-C1-12	B-33	21-3 10-11	Blue-Red Red	Completes circuit to "A" motor.
Carryover B. N. C.	ASW-C2-2	R-42	75-11 14-14	Orange-White Red-Green	Opens circuit to "B" motor Carryover cam sw.
"B" Motor	E-119-475	A-35	70 20-11	Orange Blue	Energizes Motor.
Carryover A. N. O.	ASW-C1-12	B-34	21-3 20-11	Blue-Red Blue	Completes circuit to "B" Motor.
Carryover B. N. C.	ASW-C2-2	R-43	18-16 14-14	Red-Black Red-Green	Opens circuit to "C" motor carryover cam sw.
"C" Motor	E-119-475	A-36	70 80-12	Orange Black	Energizes "C" Motor.
Carryover A. N. O.	ASW-C1-12	B-35	21-3 80-12	Blue-Red Black	Completes circuit to "C" Motor
Carryover B. N. C.	ASW-C2-2	R-43	41-14 18-16	Green-Red Red-Black	Opens circuit to "D" motor carry- over cam sw.
"D" Motor	E-119-475	A-37	70 40-11	Orange Green	Energizes "D" motor.
Carryover A. N. O.	ASW-C1-12	B-36	21-3 40-11 71 J	Blue-Red Green Black-White	Completes circuit to "D" motor.
Carryover B. N. C.	ASW-C2-2	R-44	58-13 41-14	White-Black Green-Red	Opens circuit to "E" motor carry- over cam sw.
"E" Motor	E-119-475	A-38	70 50-11	Orange White	Energizes "E" motor.
Carryover A. N. O.	ASW-C1-12	B-37	21-3 50-11	Blue-Red White	Completes circuit to "E" motor.
Carryover B. N. C.	ASW-C2-2	R-44	10 58-13	Red White-Black	Opens circuit to A, B, C, D carry- over cam sws.

ALWAYS GIVE MODEL AND PART NO. WHEN ORDERING SERVICE PARTS

CONTROL UNIT ASSEMBLY

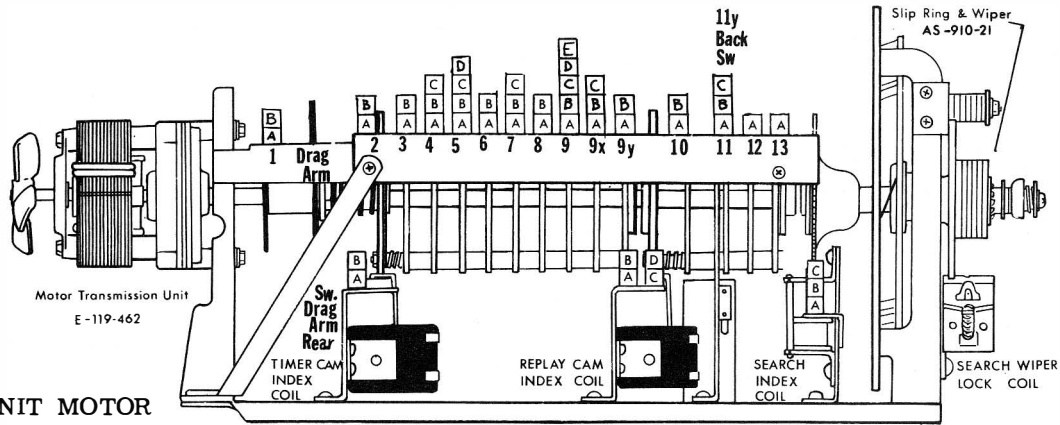

CONTROL UNIT MOTOR

E-119-462 50/60 Cy. 23.4 R. P. M. Domestic
 E-119-370 50 Cy. only 25 R. P. M. Belgium

The correct adjustment & synchronization of the Switches controlled by Cam No. 's 10A & 12 is vitally important to the Replay Counter Circuit. Out of adjustment Back Switches (12-C & 10A-A) can cause the four Replay Counters to become overloaded & burn out (affects the Printed Circuit Disc). Figure 3 shows these Cam Switches in a proper "Made" position. The Back Switches are adjustable. Note that the 12-C switch closes first & opens last. Cam Switch 12X is used for our testing purposes only.

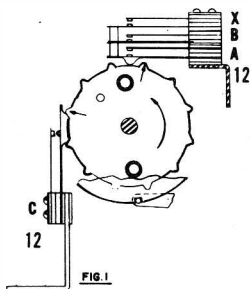

Replay Cam 12 shown in a normal indexed position. Switches 12 A, B, C are open.

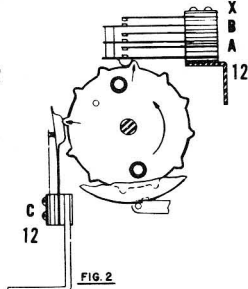

Cam 12 starting to rotate. Switches out of indexed pos. Switches A & B are open, Switch C is closed.

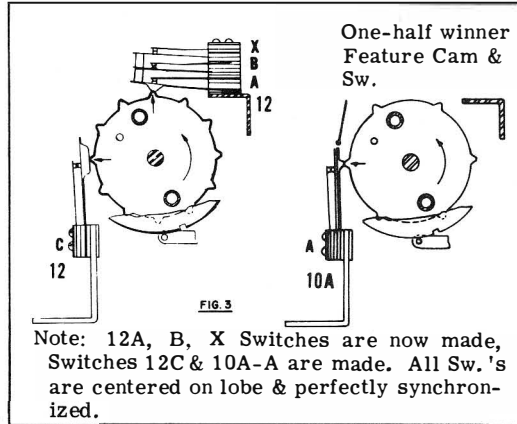

Note: 12A, B, X Switches are now made, Switches 12C & 10A-A are made. All Sw. 's are centered on lobe & perfectly synchronized.

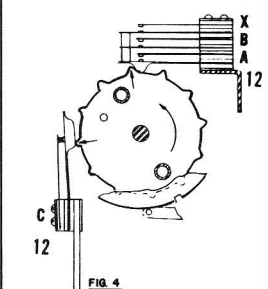

Cam #12 Switches A & B are now open again, however Switch C is still closed. After this cycle Cam & Switches return to the Fig. 1 position (open).

This entire sequence is repeated throughout the scoring cycle.

ADJUSTMENT PROCEDURES

Adjust Height and Switch so that the entire bent part of Switch Blade fits between Cam Lobes firmly on Cam & at Cam Center.

With Replay Cam Index Pin in Index Cam Notch. Replay Cam Index must be adjusted in so that switches are positioned between Cam Lobes as shown.

3/4 of Space from last Lobe

Cam #13 Back Up Switch

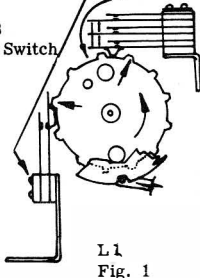

Replay Cams shown in their normal Indexed Positions. Switches are Open. Arrows point to Lobes that will actuate Switches.

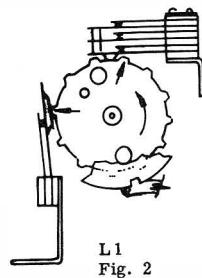

Replay Cams shown starting to Rotate they are now out of their Indexed Positions. Switches 1G, 2G & 3G are Open Switch L1 is now Open, Switch L1 is now Closed.

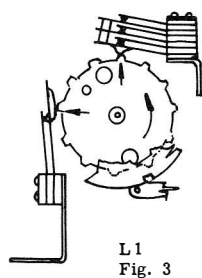

Switches 1G, 2G & 3G are now Closed. Switch L1 is still closed.

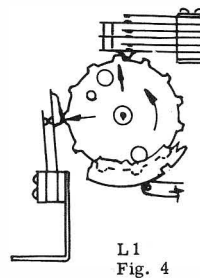

Switches 1G, 2G & 3G are now Open again. Switch L1 is still closed.

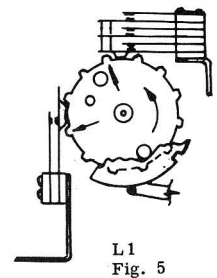

All Switches are now Open again. Same as in Fig. 1. This sequence is repeated thruout Replay Scoring Cycle.

ALWAYS GIVE MODEL AND PART NO. WHEN ORDERING SERVICE PARTS

CONTROL UNIT FUNCTION CHART

Switch/Coil	Part No.	Location on Diagram	Wire No.	Wire Color	Function
Motor Dom. Belguim Motor	E-119-359 E-119-370	F-2	98-16 95-16	Grey-Black Grey-White	Energizes control unit motor.
Cam #1 A. N. O.	ASW-C1-25	F-12	65-2 36-9	Brown-White Yellow-Brown	Completes circuit to C. U. drag arm sw.
Cam #1 B. N. C.	ASW-C1-3	D-9	10-15 56-14	Red White-Brown	Opens circuit to mixer latch coil (B-9)
Drag Arm Sw. N. O.	ASW-AO-2	E-12	36-9 78-6	Yellow-Brown Orange-Black	Completes circuit to before 5th sel. lock trip sw.
Cam #2 A. N. C.	ASW-C2-28	F-14	57-6 31-7	White-Orange Yellow-Red	Opens circuit to red button relay sw.
Cam #2 B. N. C.	ASW-C2-2	G-7	52-11 30	White-Blue Yellow	Opens circuit to multi-play relay sw.
Cam #3 A. N. C.	ASW-C1-3	H-5	30 48-11	Yellow Green-Black	Opens circuit to start relay sw. & replay register 'O' sw.
Cam #3 B. T.	ASW-C3-3	B-21	78-1 51-12 83-13	Orange-Black White-Red Black-Yellow	NOT USED
Cam #4 A. N. O.	ASW-C1-3	D-8	75-13 27-13	Orange-White Blue-Orange	Completes circuit to coin meter coil.
Cam #4 B. N. O.	ASW-C1-8	D-54	71-2 61-8	Orange-Red Brown-Red	Completes circuit to anti-cheat relay coil.
Cam #4 C. N. O.	ASW-C1-8	G-49	30 23-11	Yellow Blue-Yellow	Completes circuit to mixer spotting cams index coil.
Cam #5 A. N. O.	ASW-C1-3	E-56	85-4 10-7	Black-White Red	Completes circuit to a pad on each score unit disc.
Cam #5 B. N. O.	ASW-C1-8	F-62	85-4 52-9	Black-White White-Blue	Completes circuit to selection feature disc pad.
Cam #5 C. N. O.	ASW-C1-8	B-53	21-1 38-4	Blue-Red Yellow-Black	Completes circuit to extra ball step-up coil.
Cam #5 D. N. O.	ASW-C1-8	F-12	65-2 71-8	Brown-White Orange-Red	Completes circuit to C. U. cam #1 sw.
Cam #6 A. N. C.	ASW-C1-4	I-54	51-5 75-5	White-Red Orange-White	Opens circuit to wiper feeds on mixer #4 disc.
Cam #6 B. N. O.	ASW-C2-4	H-49	30 25-9	Yellow Blue-White	Completes circuit to score extra step index coil.
Cam #7 A. N. O.	ASW-C1-3	D-56	85-4 60-6	Black-White Brown	Completes circuit to all 4 score unit discs.
Cam #7 B. N. O.	ASW-C1-8	F-54	63-4 45-9	Brown-Yellow Green-White	Directs circuit to mixer wiper fd. and pad on white score disc.
Cam #7 C. N. O.	ASW-C1-8	H-3	30 80-15	Yellow Black	Direct circuit to reflex play magnet and also replay reset register circuit
Cam #8 B. N. O.	ASW-C1-8	G-61	14-8 56-6	Red-Green White-Brown	Completes circuit to wiper feed on mixer spotting disc & also pad on sel. fea. disc.
Cam #8 A. N. O.	ASW-C1-3	B-54	25-4 38-4	Blue-White Yellow-Black	Completes circuit to extra ball step-up coil.
Alt. Cam #9 A. N. O.	ASW-C1-4	D-65	36-14 52-13	Yellow-Black White-Blue	Completes circuit to "Any 2 trip" Sw. & coil.
Alt. Cam #9 B. N. O.	ASW-C1-8	E-59	32 65-4	Yellow-Blue Brown-White	Completes circuit to Mixer #3 disc pad.
Alt. Cam #9 C. N. C.	ASW-C2-4	D-53	43-5 74-10	Green-Yellow Orange-Green	Completes circuit to pad on extra ball unit disc.
Alt. Cam #9 D. N. C.	ASW-C2-2	C-63	75-3 10-2	Orange-White Red	Opens circuit to red letter win #1 relay sw.
Alt. Cam #9 E. N. C.	ASW-C2-2	C-64	53-8 14-11	White-Yellow Red-Green	Opens circuit to corners trip sw. & coil.

ALWAYS GIVE MOEEL AND PART NO. WHEN ORDERING SERVICE PARTS

CONTROL UNIT FUNCTION CHART

Switch/Coil	Part No.	Location on Diagram	Wire No.	Wire Color	Function
Alt. Cam #9X A. N. O.	ASW-C2-18	H-52	85-4 31-30	Black-White Yellow-Red	Directs circuit to score extra step pulse switch.
Alt. Cam #9X B. T.	ASW-C3-2	P-6	18-14 45-5 10-9	Red-Black Green-White Red	Directs circuit to either yellow rollover lite or red rollover lite.
Alt. Cam #9X C. T.	ASW-C3-3	F-65	25-10 60-10 61-9	Blue-White Brown Brown-Red	Yellow or red rollover circuit to rollover trip sw. (D-65).
Cam #9Y A. N. O.	ASW-C1-3	D-20	30 36-12	Yellow Yellow-Brown	Single coin - completes circuit to multi-play relay sw.
Cam #9Y B. LUG	ASW-A0-3	D-20	LUG 36-12	Yellow-Brown	Multi-Coin
Cam #10 A. N. O.	ASW-C1-3	A-29	57 70	White-Orange Orange	(X8) Sw. pulses replay counter step up coils depending upon position of score unit wipers.
Cam #10 B. LUG	ASW-A0-3	D-20	LUG 30	Yellow	
Cam #11 A. N. O.	ASW-C1-3	B-22	41-9 80	Green-Red Black	(X1) Sw. pulses reflex replay magnet.
Cam #11 B. N. O.	ASW-C1-8	A-25	43-4 70	Green-Yellow Orange	(X1) Sw. pulses replay counter step up coils depending upon position of score unit wipers.
Cam #11 C. NO EXTRA SWITCH	ASW-C1-8	A-25	70 J	Orange	
Cam #11Y A. N. O.	Back Sw.	O-22	36-8 21-3	Yellow-Brown Blue-Red	Completes circuit to prevent arcing on replay counter discs.
Cam #12 A. N. O.	ASW-C1-3	A-26	52 70	White-Blue Orange	(X4) Sw. pulses replay counter step up coils depending upon position of score unit wipers.
Cam #13 A. N. C.	ASW-C1-4	I-21	74-14 56	Orange-Green White-Brown	Completes circuit to before 4th sel. lock trip sw.
Search Wiper Lock Cam	ED-30-1300	A-24	70 23-12	Orange Blue-Yellow	Energizes relay coil.
Search Cam Pin Sw. A. N. O.	ASW-C1-25	A-24	38-13 23-12	Yellow-Black Blue-Yellow	Completes circuit to search wiper index coil.
Search Cam Pin Sw. B. N. O.		C-5	41-11 13-12	Green-Red Red-Yellow	Completes circuit to key sw.
TIMER CAMS Index Coil	BF-27-1250	B-9	10-15 15-12	Red Red-White	Energizes Timer Cam Index Coil.
A. N. O.	ASW-A1-43	B-9	94-16 98-16	Grey-Green Grey-Black	Completes circuit to C. U. Motor & mixer motor.
B. N. C.	ASW-A2-18	E-15	18-15 30	Red-Black Yellow	Opens circuit to red & yellow button sws.
C. N. C.	ASW-A2-35	G-8	27-13 81-13	Blue-Orange Black-Red	Opens circuit to coin lockout coil.
REPLAY CAMS Index	CF-28-1025	A-23	70 40-7	Orange Green	Energizes Index Coil.
A. N. O.	ASW-A1-11	C-22	80 36-8	Black Yellow-Brown	Completes circuit to prevent arcing on replay counter discs.
B. N. C.	ASW-A2-27	B-23	80 15-2	Black Red-White	Opens circuit to search index coil.
C. N. O.	ASW-A1-56	H-21	74-14 56	Orange-Green White-Brown	Completes circuit to before 4th selector lock trip.
D. N. C.	ASW-A2-29	C-11	14-13 27-2	Red-Green Blue-Orange	Opens circuit to timer step-up unit.
SEARCH INDEX Coil	EA-29-950	A-24	70 15-2	Orange Red-White	Energizes search index coil.
A. LUG		A-24	70 J	Orange	
B. N. O.	ASW-A2-28	B-23	40-7 72	Green Orange-Blue	Completes circuit to replay cams index coil.
C. N. C.	ASW-A1-69	F-66	83-3 27-10	Black-Yellow Blue-Orange	Opens circuit to wiper feed on selection feature disc.

C. U. SEARCH DISC WIPER UNIT & POSITIONS CHART

Winners Read Across

	1	2	3	4	5
1					
2					
3					
4					
5	KK		OO		
6					
7	WW		CC		
8					
9	WW		KK		OO
10					
11	OO		WW		CC
12					
13	CC		OO		KK
14					
15	KK		CC		WW
16					
17	CC	KK	OO	WW	
18					
19	A	E	Y	U	
20					
21					
22	EE	II	MM	QQ	UU
23	AA	GG	MM	SS	YY
24	DD	II	NN	SS	XX
25	BB	GG	LL	QQ	VV
26	KK	LL	MM	NN	OO
27					
28	EE	JJ	OO	TT	YY
29	CC	HH	MM	RR	WW
30	AA	FF	KK	PP	UU
31	UU	VV	WW	XX	YY
32	PP	QQ	RR	SS	TT
33	FF	GG	HH	II	JJ
34	AA	BB	CC	DD	EE
35					
36	E	I	M	O	U
37	A	G	M	S	Y
38	D	I	N	S	X
39	B	G	L	Q	V
40	K	L	M	N	O
41					
42	E	J	O	T	Y
43	C	H	M	R	W
44	A	F	K	P	U
45	U	V	W	X	Y
46	P	Q	R	S	T
47	F	G	H	I	J
48	A	B	C	D	E
49					
50					

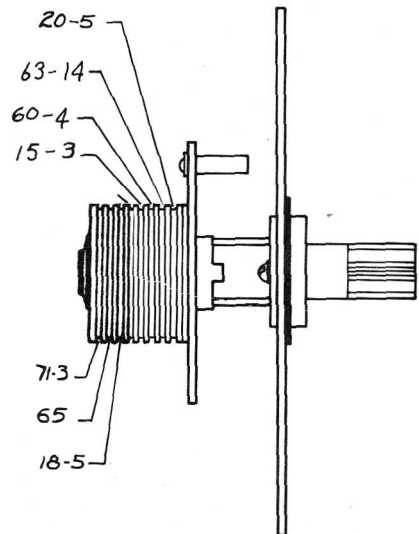
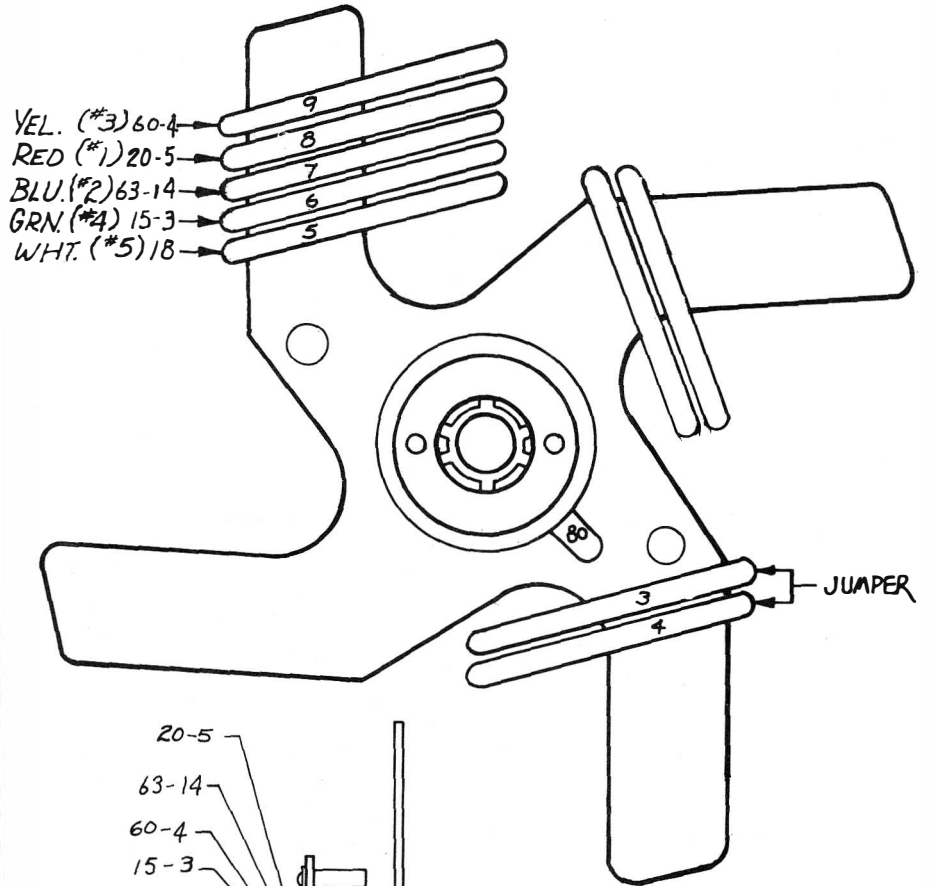

PICTORIAL CARD HOLE REFERENCE

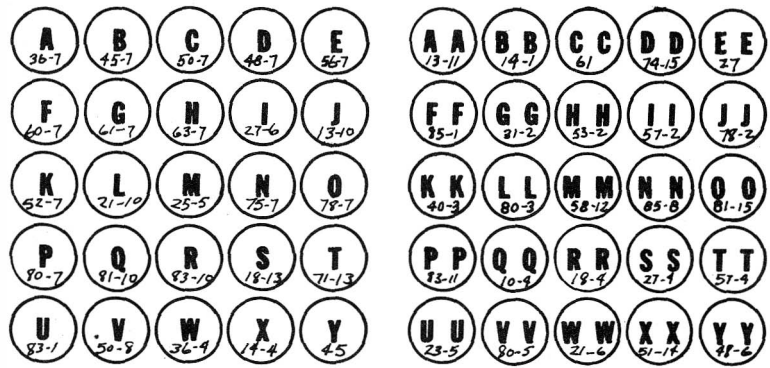

NOTE: LETTERS ARE REFERENCE ONLY. NUMBERS ARE WIRE CODE.

ALWAYS GIVE MODEL AND PART NO. WHEN ORDERING SERVICE PARTS

CONTROL DISC ASSEMBLY

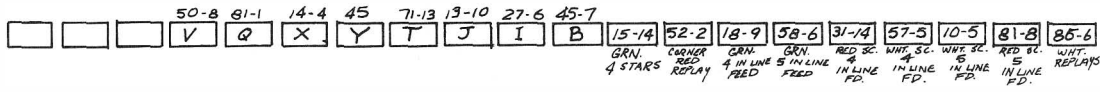

RED LETTER WIN RELAY

LITES

YEL. 4 IN LINE FEED 5 IN LINE FEED LITE

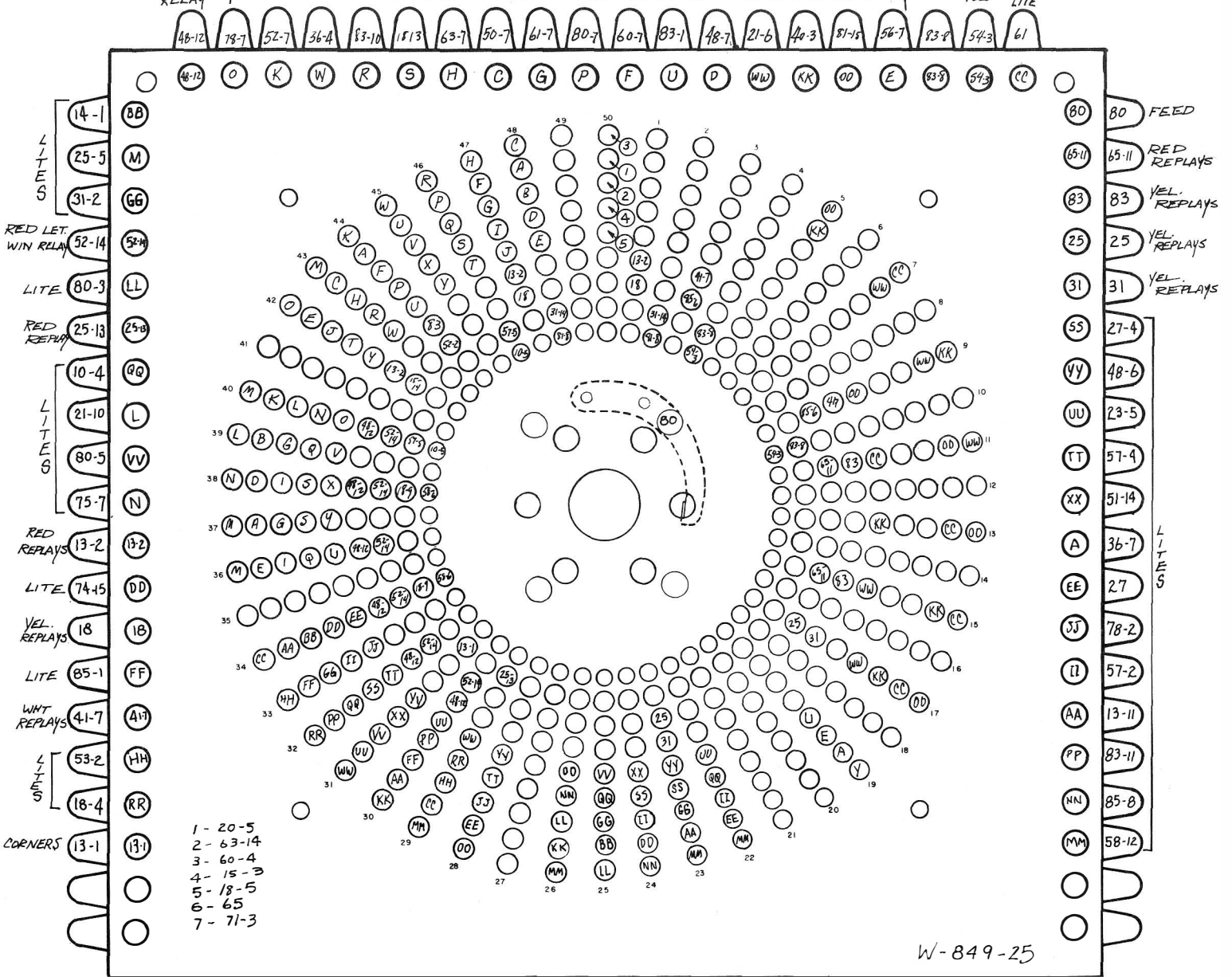

PROGRAM DISC ASSEMBLY

83-7	13-6	15-1	71-5	52-7	75-10	38-6	23-1	65-5	74-7
40	47	38	53	43	33	45	35	54	41
WH 128	RED 32	GRN 4	VEL 44	WH 8	GRN 12	RED 128	GRN 32	VEL 32	WH 32

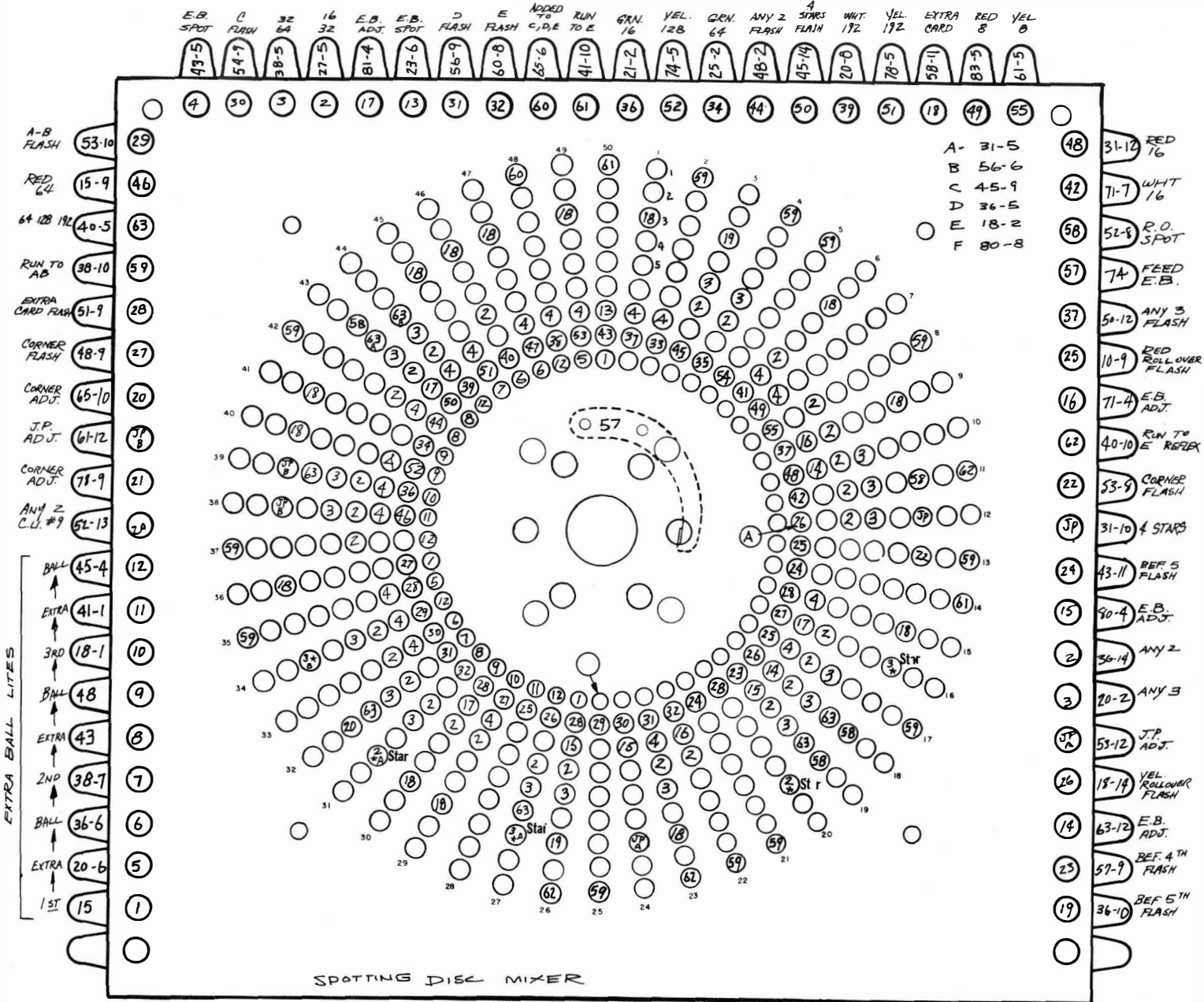

MIXER & SPOTTING UNIT

Leather Clutch Washers on this unit require periodic lubrication. Neats Foot Oil should be used when necessary.

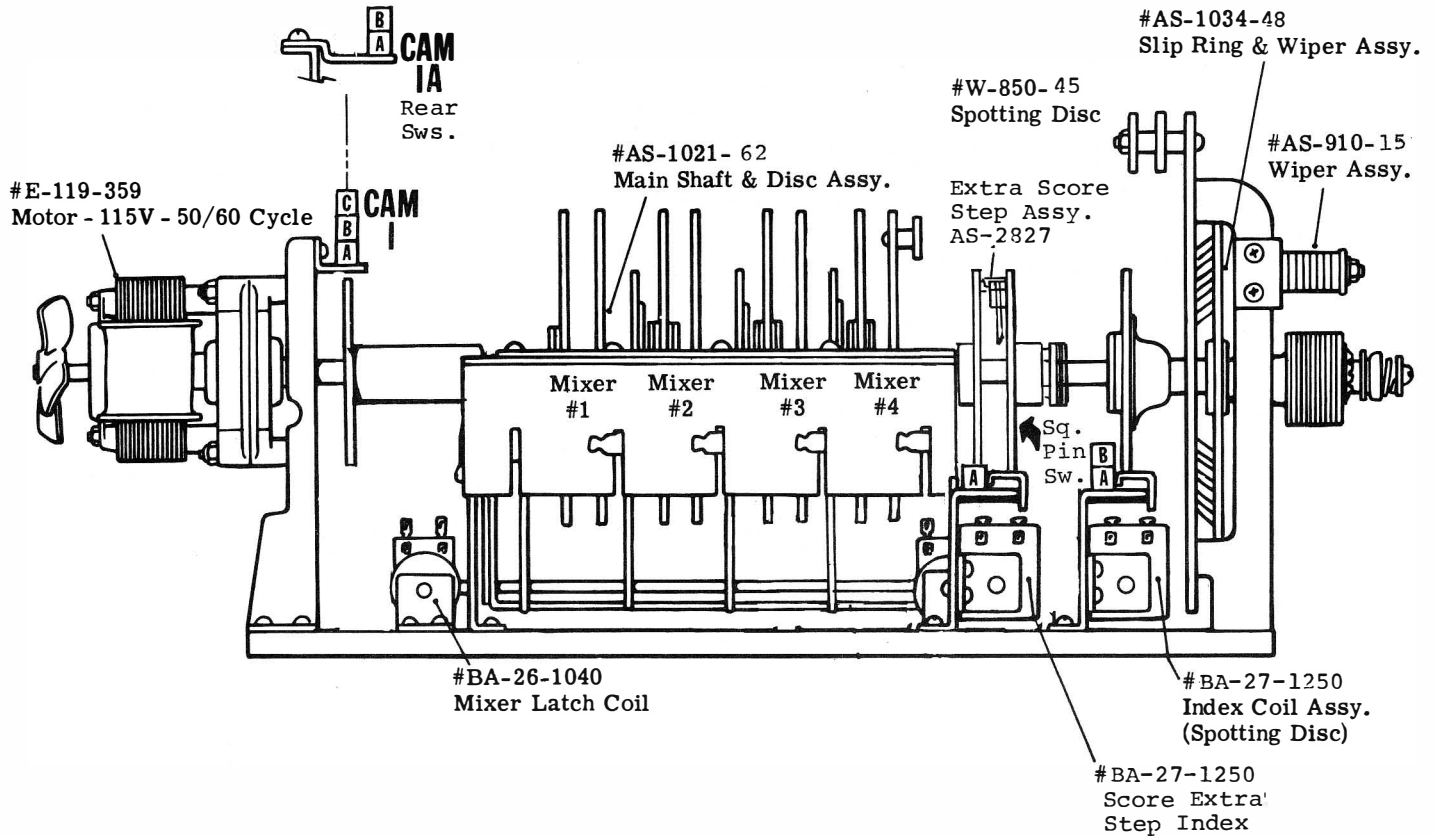

Note: All of the following Contact Plate Discs & Wiper Units are wired internally.

#W-850-45	Spotting Disc	#W-810	#3 Contact Plate Disc & Ring
#AS-1034-48	Slip Ring & Wiper	#W-810-1	#3 Index Disc & Wiper
#W-809	#1 Contact Plate Disc & Ring	#W-811	#4 Contact Plate Disc & Ring
#W-809-1	#1 Index Disc & Wiper	#W-811-1	#4 Index Disc & Wiper
#W-871-5	#2 Contact Plate Disc & Ring		
#W-871-7	#2 Index Disc & Wiper		

ALWAYS GIVE MODEL AND PART NO. WHEN ORDERING SERVICE PARTS

MIXER FUNCTION CHART

Switch/Coil	Part No.	Location on Diagram	Wire No.	Wire Color	Function
MIXER MOTOR	E-119-359	F-2	95-16 98-16	Grey-White Grey-Black	Energizes Motor
Cam #1 A. N. O.	ASW-C1X-1	P-3	56-2 53-7	White-Brown White-Yellow	Completes circuit to select now lite.
Cam #1 B. N. O.	ASW-C1X-2	G-61	14-8 80-8	Red-Green Black	Completes circuit to wiper feed, mixer spotting disc.
Cam #1 C. N. O.	ASW-C1X-2	F-4	75-2 10-14	Orange-White Red	Completes circuit to replay reset sw. (D-4)
Cam #1A A. N. O.	ASW-C1X-1	A-52	47 38-4	Green-Orange Yellow-Black	Circuit pulses extra ball step-up coil.
Cam #1A B. N. O.	ASW-C1X-2	F-68	27-14 48-5	Blue-Orange Green-Black	Circuit pulses red letter step-up coil.
SCORE EXTRA Step Index	BF-27-1250	A-49	70 25-9	Orange Blue-White	Energizes relay coil.
A. N. O.	ASW-A1-11	F-67	13-5 81-3	Red-Yellow Black-Red	Completes circuit to score extra step relay.
SCORE EXTRA Step Pul. Sw. N. O.	ASW-A1-132	E-57 50-4	31-30 50-4	Black-White White	Completes circuit to score extra step relay sw.
SQ. PIN Sw. N. C.	ASW-A20-16	G-67	21-3 13-5	Blue-Red Red-Yellow	Opens circuit to extra step index sw.
SPOTTING Index	BF-27-1250	A-49	70 23-11	Orange Blue-Yellow	Energizers index coil.
A. N. O.	ASW-A1-11	J-19	30 61-4	Yellow Brown-Red	Directs circuit to extra ball #2 trip sw.
B. N. O.	ASW-A1-54	J-26	30 13-4	Yellow Red-Yellow	Directs circuit to extra ball #2 trip sw.
MIXER LATCH	BA-26-1040	B-8	56-14 15-12	White-Brown Red-White	Energizes mixer latch coil.

ALWAYS GIVE MODEL AND PART NO. WHEN ORDERING SERVICE PARTS

12 TRIP BANK

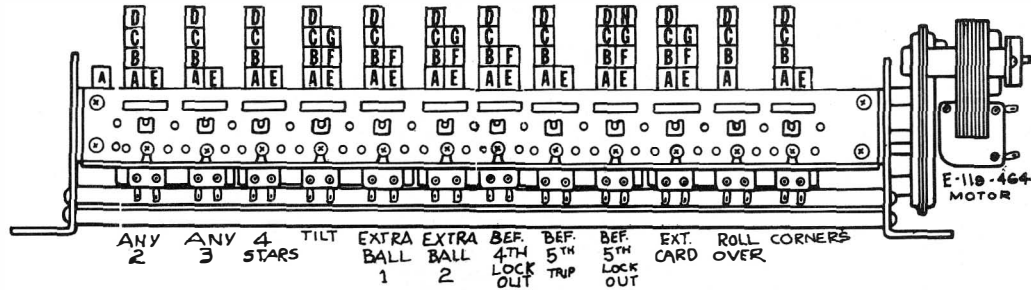

Switch/Coil	Part No.	Location on Diagram	Wire No.	Wire Color	Function	
ANY 2 TRIP	D-27-425	A-65	70 36J	Orange Yellow-Brown	Energizes 2 Trip Relay.	
A.	N. C.	ASW-B-2	A-65	36J 36-14	Yellow-Brown Yellow-Brown	Opens Circuit to Relay Coil.
B.	N. O.	ASW-B-1	B-65	20-2 36-14	Blue Yellow-Brown	Completes Circuit to any 3 Trip Switch.
C.	N. O.	ASW-B-1	G-33	63-8 43-12	Brown-Yellow Green-Yellow	Completes Circuit to "R" Button Switch.
D.	T.	ASW-B-3	L-32	50-12 58-1 48-2	White White-Black	Completes Circuit to any two lite or any three lite.
E.	N. C.	ASW-B-2	B-57	56-10 62	White-Brown Brown-Blue	Opens Circuit to Red Score Unit Disc Pad
ANY 3 TRIP	D-27-425	A-66	70 20J	Orange Blue	Energizes 3 Trip Relay	
A.	N. C.	ASW-B-2	A-66	20-2 20J	Blue Blue	Opens Circuit to Any 3 Trip Relay.
B.	N. C.	ASW-B-2	E-58	32 65-4	Yellow-Blue Brown-White	Opens Circuit to Mixer #3 Disc
C.	N. O.	ASW-B-1	G-32	63-8 41-13	Brown-Yellow Green-Red	Completes Circuit to "R" Button Sw.
D.	N. O.	ASW-B-1	J-32-	58-1 51-9	White-Black White-Red	Completes Circuit to any 3 Lite
E.	N. C.	ASW-B-2	B-50	34 54-12	Yellow-Green White-Green	Opens the Circuit to the Mixer 16 Pulse Cam #1A
4 STARS	D-27-425	A-67	70 31J	Orange Yellow-Red	Energizes 4 Star Relay	
A.	N. C.	ASW-B-2	A-67	31-10 31J	Yellow-Red Yellow-Red	Opens Circuit to 4 Star Relay.
B.	N. O.	ASW-B-1	D-30	18 15-14	Red-Black Red-White	Completes Circuit on Control Unit Search Disc (D-30)
C.	N. O.	ASW-B-1	L-33	51-9 45-14	White-Red Green-White	Completes Circuit to Extra Card Lite.
D.	N. O.	ASW-B-1	G-24	61-3 25-13	Brown-Red Blue-White	Completes Circuit feeds to wipers on all Score Unit Discs.
E.	N. C.	ASW-B-2	B-50	47 34	Green-Orange Yellow-Green	Opens Circuit to 16 Pulse Mixer Unit Switch.

ALWAYS GIVE MODEL AND PART NO. WHEN ORDERING SERVICE PARTS

12 TRIP BANK

Switch/Coil	Part No.	Location on Diagram	Wire No.	Wire Color	Function
BEFORE 4th LOCKOUT	D-27-425	A-14	70 83 J	Orange Black-Yellow	Energizes before 4th Lock Trip Relay Coil.
A. N. C.	ASW-B-2	A-14	83-6 83 J	Black-Yellow Black-Yellow	Opens Circuit to Relay Coil.
B. N. C.	ASW-B-2	M-3	27-11 58-9	Blue-Orange White-Black	Opens Circuit to Select before 5th Trip Sw.
C. N. C.	ASW-B-2	G-66	31-11 20-10	Yellow-Red Blue	Opens Circuit to before 5th select Lock Trip Sw.
D. N. O.	ASW-B-1	I-22	56 45-6	White-Brown Green-White	Completes Circuit to Search Relay Switches.
E. N. O.	ASW-B-1	B-24	38-13 52-5	Yellow-Black White-Blue	Completes circuit to Search Wiper Pin Switch.
F. N. O.	ASW-B-1	F-11	36-2 43-2	Yellow-Brown Green-Yellow	Completes Circuit to Ball Lifter Cam #2 Sw.
BEFORE 5th TRIP	D-27-425	A-65	70 15 J	Orange Red-White	Energizes before 5th Trip Relay Coil.
A. N. C.	ASW-B-2	A-65	15-11 15 J	Red-White Red-White	Opens Circuit to Relay Coil.
B. N. C.	ASW-B-2	C-50	75 27-7	Orange-White Blue-Orange	Opens Circuit to Extra Card Sw. & Extra Ball Trip Sw. (G-52).
C. T.	ASW-B-3	K-3	58-9 80-9 23-10	White-Black Black Blue-Yellow	Directs Circuit to before 5th Sel. Lock Trip Sw. from Timer Disc direct or through bef. 4th Sel. Lock Trip Sw.
D. T.	ASW-B-3	P-5	57-9 53-10 43-11	White-Orange White-Yellow Green-Yellow	Directs Circuit to Lites, either select before 4th or select before 5th.
E. N. O.	ASW-B-1	G-65	31-11 20-10	Yellow-Red Blue	Opens Circuit to select before 5th Lock Trip Sw.
BEFORE 5th LOCKOUT	D-27-425	A-13	70 74 J	Orange Orange-Green	Energizes before 5th sel. lock trip coil.
A. N. C.	ASW-B-2	A-13	74-6 74 J	Orange-Green Orange-Green	Opens Circuit to before 5th Lockout Relay Coil.
B. N. C.	ASW-B-2	L-6	53-10 80-9	White-Yellow Black	Opens circuit to select magic lines A. B. lite.
C. N. C.	ASW-B-2	G-66	20-10 83-3	Blue Black-Yellow	Opens circuit to search Index Sw.
D. N. C.	ASW-B-2	C-65	18-10 15-11	Red-Black Red-White	Opens Circuit to select before 5th Relay Coil.
E. N. O.	ASW-B-1	C-16	23-8 50-13	Blue-Yellow White	Completes Circuit to extra ball trips relay coil.
F. N. O.	ASW-B-1	D-12	78-6 27-2	Orange-Black Blue-Orange	Completes circuit to replay cams index sw. through which steps up timer.
G. N. O.	ASW-B-1	G-13	31-13 71-8	Yellow-Red Orange-Red	Directs circuit to timer unit reset coil sw.
H. N. O.	ASW-B-1	C-17	25-12 38-3	Blue-White Yellow-Black	Completes circuit to ball lifter motor.
EXTRA CARD	D-27-425	A-63	70 58 J	Orange White-Black	Energizes extra card relay coil.
A. N. C.	ASW-B-2	A-63	58-11 58 J	White-Black White-Black	Opens circuit to extra card relay coil.
B. N. C.	ASW-B-2	G-52	10-1 27-7	Red Blue-Orange	Open circuit to extra ball #1 Trip Sw. (See Diagram)
C. N. C.	ASW-B-2	E-50	40-9 80-6	Green Black	Opens circuit to wiper feed on mixer #2 disc.
D. N. O.	ASW-B-1	D-29	48-4 18	Green-Black Red-Black	Completes circuit to pad on control unit search disc.

ALWAYS GIVE MOEEL AND PART NO. WHEN ORDERING SERVICE PARTS

12 TRIP BANK

Switch/Ball	Part No.	Location on Diagram	Wire No.	Wire Color	Function
TILT TRIP	D-27-425	A-17	70 14-5	Orange Red-Green	Energized via key sw., all Tilt Sws. and Ball Lifter Cam #2 Sw.
A. N. C.	ASW-B-2	H-66	40-8 31-11	Green Yellow-Red	Opens Circuit to the before 4th, and before 5th Sws.
B. N. C.	ASW-B-2	R-41	20-4 75-11	Blue Orange-White	Opens Circuit to the Magic Line Lites.
C. N. C.	ASW-B-2	H-2	96-16 98-16	Grey-Brown Grey-Black	Opens Circuit to the C. O. Motor and Mixer Unit Motor.
D. T.	ASW-B-3	R-40	38 18-12 74-11	Yellow-Black Red-Black Orange-Green	Opens Circuit to Fuse Block & Completes Circuit to Tilt Lite.
E. N. O.	ASW-B-1	E-16	57-6 85-7	White-Orange Black-White	Completes Circuit to Red Button Relay.
F. N. O.	ASW-B-1	C-5	41-11 13-12	Green-Red Red-Yellow	Completes Circuit to Start Relay.
G. T.	ASW-B-3	H-10	21-3 30 45-8	Blue-Red Yellow Green-White	Directs Circuit to Shutter Motor Cam #4 Sw. (C. W. O.)
EXTRA BALL #1	D-27-425	A-15	70 50 J	Orange White	Energized via sel. before 5th Lock Trip Sw. (B-15).
A. N. C.	ASW-B-2	H-53	45-2 83-9	Green-White Black-Yellow	Opens Circuit to start relay sw. which open Wiper Cir. to Mixer through C. O. (G-63).
B. N. C.	ASW-B-2	E-54	85-4 71-2	Black-White Orange-Red	Open Cir. to C. U. Cam #4 Sw.
C. N. O.	ASW-B-1	K-39	30 21-4	Yellow Blue-Red	Completes Cir. to Red Button Relay sw. & Extra Ball Lite.
D. T.	ASW-B-3	E-54	85-4 30 61-2	Black-White Yellow Brown-Red	Directs circuit to extra ball unit disc when relay pulls in.
E. N. O.	ASW-B-1	G-52	54-8 10-1	White-Green Red	Completes circuit to extra ball trip sw.
F. T.	ASW-B-3	F-52	63-4 27-2 18-2	Brown-Yellow Blue-Orange Red-Brown	Directs Circuit to C. U. Cam 7 Sw., directing cir. to mixer wiper & all score unit discs.
EXTRA BALL #2	D-27-425	A-16	70 50 J	Orange White	Energizes extra ball relay
A. N. C.	ASW-B-2	A-16	50-13 50 J	White White	Opens Circuit to Extra Ball Relay.
B. N. C.	ASW-B-2	L-19	36-5 61-4	Yellow-Brown Brown-Red	Opens Circuit to Wiper feeds on Mixer Spotting Disc
C. T.	ASW-B-3	L-26	31-5 13-4 74	Yellow-Red Red-Yellow Orange-Green	Directs Circuit to Alternating Pads on Spotting Disc
D. T.	ASW-B-3	I-52	75-5 15-7 45-2	Orange-White Red-White Green-White	Directs Circuit through Mixer #4 Relay.
E. N. O.	ASW-B-1	F-5	51-11 63-2	White-Red Brown-Yellow	Completes Circuit to Yellow Button Switch.
F. N. O.	ASW-B-1	B-18	25-12 38-3	Blue-White Yellow-Brown	Completes Circuit to Ball Lifter Motor.
G. T.	ASW-B-3	E-9	14-3 43-9 58-8	Red-Green Green-Yellow White-Black	Directs Circuit to Shutter Motor or Timer Cam Index Coil.

12 TRIP BANK

Swith/Coil	Part No.	Location on Diagram	Wire No.	Wire Color	Function
E. N. O.	ASW-B-1	D-32	81-6 85-6	Black-Red Black-White	Completes circuit to pad on control unit search disc.
F. N. O.	ASW-B-1	J-11	51-9 30	White-Red Yellow	Completes circuit to extra card lite.
G. N. O.	ASW-B-1	F-32	52-14 71-14	White-Blue Orange-Red	Completes circuit to pad on control unit search disc.
ROLLOVER TRIP	D-27-425	A-64	70 52 J	Orange White-Blue	Energizes rollover trip relay coil.
A. N. C.	ASW-B-2	A-64	52-8 52 J	White-Blue White-Blue	Opens circuit to rollover relay coil.
B. N. C.	ASW-B-2	D-51	31-9 75	Yellow-Red Orange-White	Opens circuit to select before 5th trip sw.
C. N. O.	ASW-B-1	M-6	45-5 57-9	Green-White White-Orange	Completes circuit to mixer disc spotting unit pad.
D. T.	ASW-B-3	D-65	36-10 18-10 60-10	Yellow-Brown Red-Black Brown	Circuit from mixer unit spotting pad or from C. U. al. cam #9X directed to bef. 5th sel. lock trip sw.
CORNERS TRIP	D-27-425	A-64	70 14 J	Orange Red-Green	Energizes corners trip relay coil.
A. N. C.	ASW-B-2	A-64	14-11 14 J	Red-Green Red-Green	Opens circuit to corners trip relay coil.
B. N. C.	ASW-B-2	C-63	75-3 12	Orange-White Red-Blue	Opens circuit to any 2 trip sw.
C. N. O.	ASW-B-1	J-11	48-9 30	Green-Black Yellow	Completes circuit to main card corners lites.
D. N. O.	ASW-B-1	G-24	61-3 13-1	Brown-Red Red-Yellow	Completes circuit to wiper feeds on all 4 score unit discs.
E. N. O.	ASW-B-1	D-26	65-11 52-2	Brown-White White-Blue	Completes circuit to C. U. search disc pad.
CARRYOVER SW. N. O.	ASW-B-20-1	I-10	30 83-14	Yellow Black-Yellow	Completes circuit to trip bank motor
MOTOR	E-119-464	A-9	70 83-14	Orange Black-Yellow	Energizes trip bank motor.

ALWAYS GIVE MODEL AND PART NO. WHEN ORDERING SERVICE PARTS

6 RELAY BANK

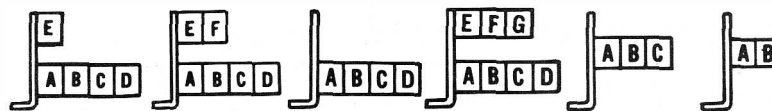
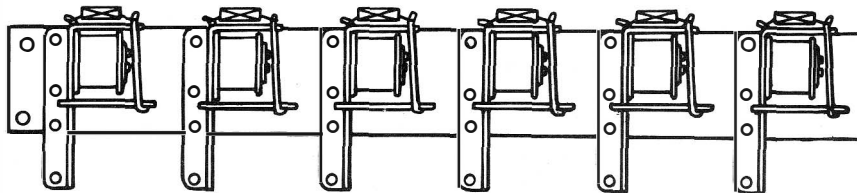

Replay Reset Start Multiplay Anti-Cheat Red Button Mixer #4

Switch/Coil	Part No.	Location on Diagram	Wire No.	Wire Color	Function
REPLAY RESET	G-30-1500	A-4	70 75-2	Orange Orange-White	Energizes replay reset relay
A. N. O.	ASW-R1-8	G-4	56-12 75-2	White-Blue Orange-White	Completes circuit to replay reset relay.
B. N. O.	ASW-R10	H-2	98-16 94-16	Grey-Black Grey-Green	Completes circuit to control unit motor mixer unit motor.
C. N. C.	ASW-R2-5	D-20	30 78-14	Yellow Orange-Black	Opens circuit to key sw.
D. N. C.	ASW-R1-5	D-5	18-11 41-11	Red-Black Green-Red	Opens circuit to search wiper pin sw.
E. T.	ASW-R3-6	D-4	80-15 58-7 10-14	Black White-Black Red	10-14 Picks up pulse from 16 pulse cam (mixer) to replay reg. reset.
START	G-30-1500	A-5	70 85-12	Orange Black-White	Energizes start relay
A. N. O.	ASW-R1X-1	G-9	13-12 74-13	Red-Yellow Orange-Green	Completes circuit to shutter motor cam #5 sw.
B. N. O.	ASW-R1X-1	H-9	13-12 48-11	Red-Yellow Green-Black	Completes circuit to start relay.
C. N. C.	ASW-R2-5	G-53	83-9 14-8	Black-Yellow Red-Green	Open circuit to C. U. Cam #8 sw. & mixer cam #1 Sw.
D. N. C.	ASW-R2-5	C-51	75-4 54-12	Orange-White White-Green	Opens circuit to mixer #2 disc # & any 3 trip sw.
E. N. C.	ASW-R2-5	D-33	23-13 15-13	Blue-Yellow Red-White	Opens circuit to red letter win #2 relay sw.
F. N. C.	ASW-R2-5	H-34	43-14 21-3	Yellow-Blue Blue-Red	Opens circuit to red letter win #1 & #2 Relay Sws.
MULTI PLAY	G-30-1500	A-6	70 13-3	Orange Red-Yellow	Energizes multi-play relay
A. N. O.	ASW-R1-3	E-6	52-11 13-3	White-Blue Red-Yellow	Completes circuit to multi-play relay.
B. N. O.	ASW-R1-3	F-6	15-5 18-11	Red-White Red-Black	Completes circuit to replay reset sw.
C. N. C.	ASW-R2-5	B-4	58-7 45-11	White-Black Green-White	Opens circuit to replay register reset.
D. T.	ASW-R3-6	C-20	41-9 75-6 36-12	Green-Red Orange-White Yellow-Brown	36-12 Circuit from C. U. cam #9y., 41-9 circuit from C. U. cam 10. (See Diagram).

ALWAYS GIVE MODEL AND PART NO. WHEN ORDERING SERVICE PARTS

6 RELAY BANK

Switch/Coil	Part No.	Location on Diagram	Wire No.	Wire Color	Function
ANTI - CHEAT	G-32125-1250	A-55	70 61 J 50 J	Orange Brown-Red White	Energizes anti-cheat relay
A. N. O.	ASW-R1-8	E-55	30 61-8	Yellow Brown-Red	Completes circuit to anti-cheat relay.
B. N. O.	ASW-R1-3	O-41	20-4 80-1	Blue Black	Completes circuit to tilt trip sw.
C. N. C.	ASW-R2-5	F-16	57-6 85-7	White-Orange Black-White	Opens circuit to red button relay coil.
D. N. C.	ASW-R2-5	H-11	23-9 45-8	Blue-Yellow Green-White	Opens circuit to shutter motor cam #4 sw.
E. N. C.	ASW-R2-5	A-54	70 50 J	Orange White	Opens circuit to half of relay coil.
F. T.	ASW-R3-6	R-38	74-11 38 54-2	Orange-Green Yellow-Black White-Green	Direct circuit to tilt lite.
G. T.	ASW-R3-6	G-5	75-2 56-12 51-11	Orange-White White-Brown White-Red	56-12 circuit to mixer cam #1 sw. or button sw. extra ball circuit (G-5)
RED BUTTON	G-32-2500	A-15	70 85-7	Orange Black-White	Energizes red button relay coil.
A. N. O.	ASW-R1-8	E-14	31-7 60-13	Yellow-Red Brown	Completes circuit to yellow button sw. & on to red button relay coil.
B. N. C.	ASW-R2-5	M-39	50-9 21-4	White Blue-Red	Opens circuit to extra ball trip #1 Sw.
C. T.	ASW-R3-6	D-9	10-15 58-8 14-3	Red White-Black Red-Green	58-8 Directs circuit to timer cam index or shutter motor.
MIXER #4	G-32-2500	A-56	70 23-4	Orange Blue-Yellow	Energizes #4 mixer #4 relay coil.
A. N. C.	ASW-R2-2	I-53	45-2 51-5	Green-White White-Red	Opens circuit to C. U. cam #6 sw.
B. LUG		H-59	21-3	Blue-Red	

ALWAYS GIVE MODEL AND PART NO. WHEN ORDERING SERVICE PARTS

3 RELAY BANK

Score Red Red
Extra Letter Letter
Step #1 #2

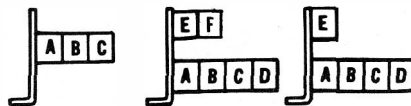
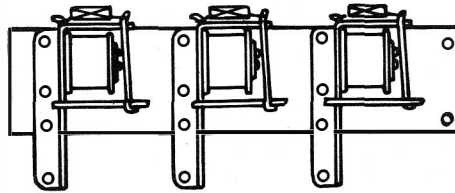

Switch/Coil	Part No.	Location on Diagram	Wire No.	Wire Color	Function
SCORE EXTRA STEP	G-32-2500	A-68	70 43-6	Orange Green-Yellow	Energizes score extra step relay coil.
A. N. O.	ASW-R1-8	E-67	81-3 43-6	Black-Red Green-Yellow	Completes circuit to coil
B. N. O.	ASW-R1-3	D-57	50-4 51-6	White White-Red	Completes circuit to fd. wiper on mixer #3 disc.
C. N. C.	ASW-R2-5	A-9	15-12 70	Red-White Orange	Opens circuit to mixer latch #2 coil & timer cam index coil.
RED LETTER WIN #1	G-32-2500	A-32	70 62-1	Orange Blue-White	Energizes red letter win #2 relay coil.
A. N. C.	ASW-R2-5	B-46	50-2 78-3	White Orange-Black	Opens circuit to red score reset coil.
B. N. C.	ASW-R2-5	B-62	10-2 20-7	Red Blue	Opens circuit to open at top sw. & relay coil sel. fea. step-up.
C. N. C.	ASW-R2-5	B-60	80-11 57-11	Black White-Orange	Opens circuit to open at top sw. & relay coil green score step-up & contact on red letter disc.
D. N. C.	ASW-R2-5	B-58	75-8 18-6	Orange-White Red-Black	Opens circuit to open at top sw. yel. score step-up & contact on red letter unit disc.
E. N. O.	ASW-R1-8	G-34	62-1 43-14	Brown-Blue Yellow-Blue	Completes circuit to red letter win #1 Relay Coil.
F. N. C.	ASW-R2-5	B-61	40-12 63-6	Green Brown-Yellow	Opens circuit to open at top sw. white score step-up & contact on red letter disc.
RED LETTER WIN #2	G-32-2500	A-32	70 25	Orange Blue-White	Energizes red letter win relay #2 coil.
A. N. O.	ASW-R1-8	C-33	23-13 25 J	Blue- Yellow Blue- White	Completes circuit to red letter win #2 Relay Coil.
B. N. O.	ASW-R1-3	C-11	38-12 21-3	Yellow-Black Blue-Red	Completes circuit to shutter sw.
C. N. O.	ASW-R1-3	G-68	48-5 31-8	Green-Black Yellow-Red	Completes circuit to mixer cam #1A Sw.
D. N. C.	ASW-R2-5	B-23	72 80	Orange-Blue Black	Opens circuit to search Index Sw.
E. N. O.	ASW-R1-3	G-33	62-1 43-14	Brown-Blue Yellow-Blue	Completes circuit to red letter win #1 relay coil.

ALWAYS GIVE MOEEL AND PART NO. WHEN ORDERING SERVICE PARTS

5 SEARCH BANK

1 Search 2 Search 3 Search 4 Search 5 Search

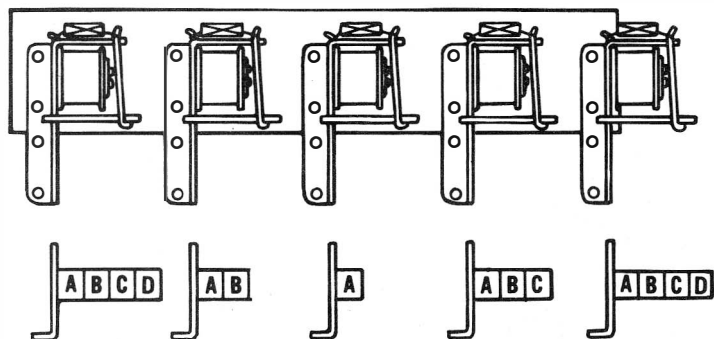

Switch/Coil	Part No.	Location on Diagram	Wire No.	Wire Color	Function
#1 SEARCH	G-28-750	P-56	10 20-5	Red Blue	Energizes Coil #1 search
A. N. O.	ASW-R1-8	H-22	52-3 65	White-Blue Brown-White	Completes circuit to C. U. Search disc pad.
B. N. O.	ASW-R1-8	H-24	53-3 71-3	White-Yellow Orange-Red	Completes circuit to C. U. search disc pad.
C. N. O.	ASW-R1-8	G-25	57-3 61-3	White-Orange Brown-Red	Completes circuit to wiper feeds to all 4 score unit discs.
D. N. O.	ASW-R1-8	I-32	50-3 43-12	White Green-Yellow	Completes circuit to #5 search relay sw. and any 2 trip sw.
#2 SEARCH	G-28-750	P-56	10 63-14	Red Brown-Yellow	Energizes coil #2 search.
A. N. O.	ASW-R1-8	I-23	50-3 52-3	White White-Blue	Completes circuit to search #1 sw. A and Search #4 Sw. C.
B. N. O.	ASW-R1-8	I-24	50-3 51-3	White White-Red	Completes circuit to search #2 sw. A and Search #4 Sw. A.
#3 SEARCH	G-28-750	P-57	10 60-4	Red Brown	Energizes coil #3 search
A. N. O.	ASW-R1-8	I-22	45-6 50-3	Green-White White	Completes circuit to search #2 Sw. A and Search #4 Sw. A.
#4 SEARCH	G-28-750	P-57	10 15-3	Red Red-White	Energizes coil #4 Search
A. N. O.	ASW-R1-8	I-24	50-3 56-3	White White-Brown	Completes circuit to Search #5 Sw. C.
B. N. O.	ASW-R1-8	I-25	51-3 53-3	White-Red White-Yellow	Completes Circuit to Search #1 Sw. B & Search #5 Sw. A. & Search #5 Sw. B
C. N. O.	ASW-R1-8	H-23	52-3 65	White-Blue Brown-White	Completes circuit to C. U. Search Disc Pad.
#5 SEARCH	G-28-750	P-58	10 18-5	Red Red-Black	Energizes coil #5 search
A. N. O.	ASW-R1-8	H-24	53-3 71-3	White-Yellow Orange-Red	Completes circuit to C. U. Search Disc Pad.
B. N. O.	ASW-R1-8	H-25	53-3 57-3	White-Yellow White-Orange	Completes circuit to search #1 Sw.
C. N. O.	ASW-R1-8	H-23	56-3 65	White-Brown Brown-White	Completes circuit to C. U. Search Disc Pad.
D. N. O.	ASW-R1-8	H-32	41-13 43-12	Green-Red Green-Yellow	Completes circuit to any 3 Trip Sw.

ALWAYS GIVE MODEL AND PART NO. WHEN ORDERING SERVICE PARTS

SELECTION FEATURE UNIT

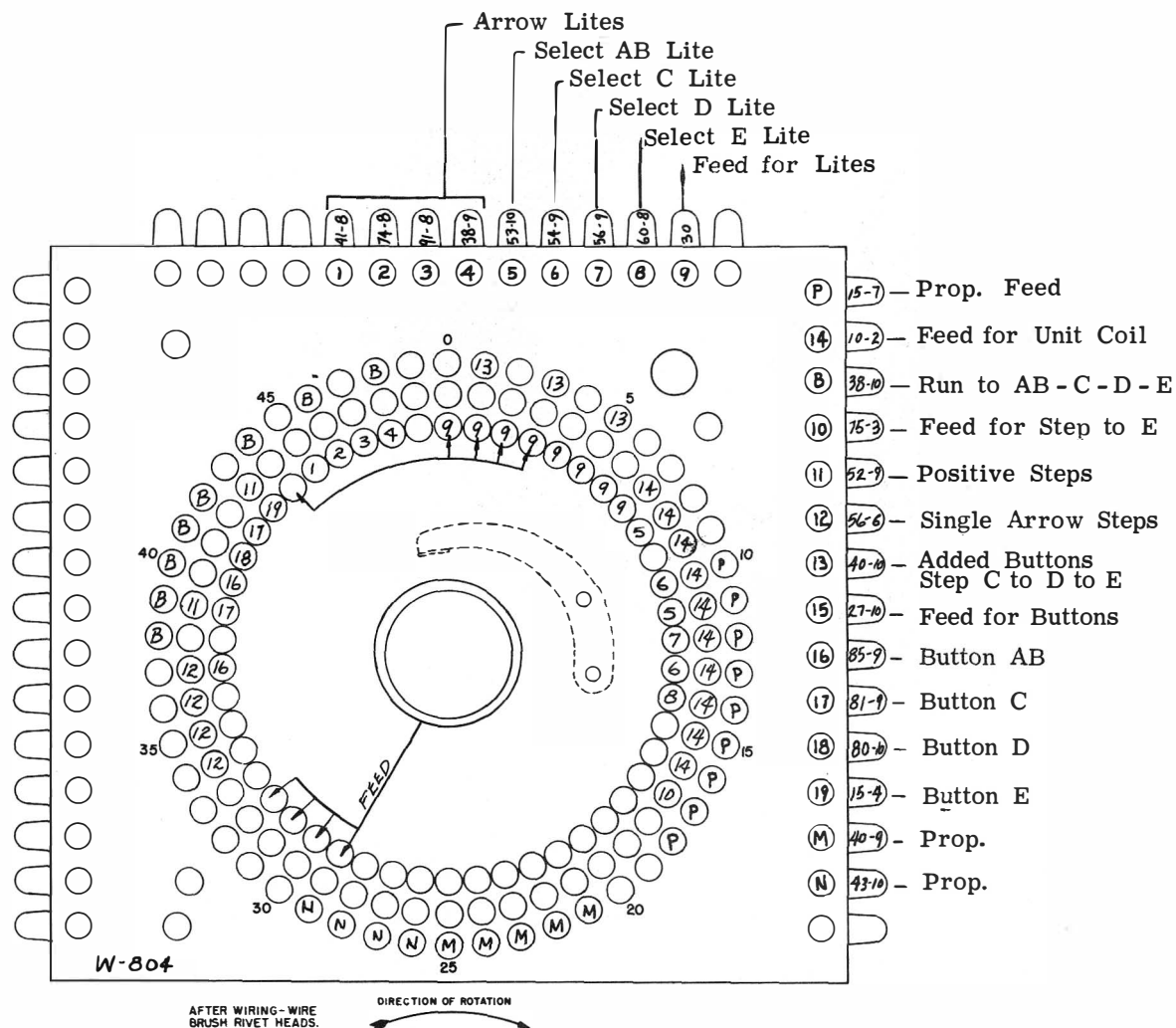

Switch/Coil	Part No.	Location on Diagram	Wire No.	Wire Color	Function
FEATURE Step-Up Coil	B-25-925	A-43	70 10-2	Orange Red	Energized via Reflex Disc & Spotting Disc Mixer Unit
FEATURE Re-Set	C-28-1100	A-50	70 78-3	Orange Orange-Black	Energized via Shutter Motor Cam #6
OPEN AT TOP A. N. C.	ASW-U2-5	B-45	53-8 14-11	White-Yellow Red-Green	Opens Circuit to Corner Trip Sw.
OPEN AT TOP B. N. C.	ASW-U2-6	D-43	41-10 75-3	Green-Red Orange-White	Opens Circuit to Selection Fea. Unit

Part No. Description

AS-827-595	Feature Stepping Unit
W-804	Contact Plate (Wired)
AS-1046-201	Wiper Assembly
C-1050-1144	Ratchet & Shaft
C-28-1100	Reset Coil
B-25-925	Step-Up Coil
A-1765-8	Step-Up Arm Assembly

ALWAYS GIVE MODEL AND PART NO. WHEN ORDERING SERVICE PARTS

REPLAY COUNTERS RED, YEL., WHT., GRN.

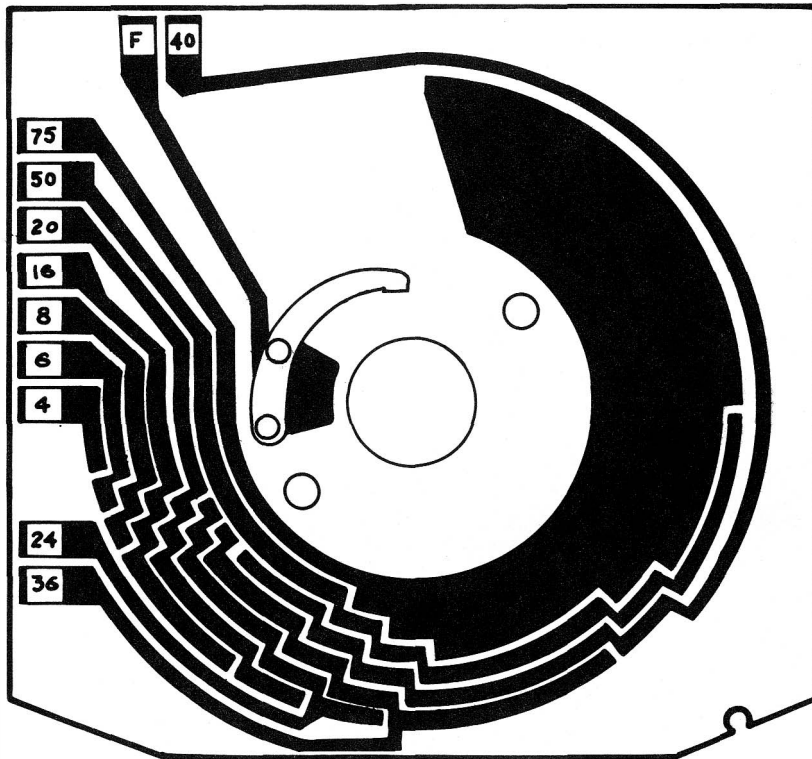

LUG	RED	YELLOW	GREEN	WHITE
50	20-3	41-2	65-3	53-6
75	23-3	51-2	74-3	54-6
F	71	23	91	61-6
36	10-3	40-2	63-3	52-6
24	85-2	23-2	60-3	50-6
20	85-2	23-2	60-3	50-6
16	83-2	93-1	48-3	31-6
8	74-2	81-1	43-3	25-6
6				
4	60-2	78-1	41-3	10-6
40				

Switch/Coil	Part No.	Location on Diagram	Wire No.	Wire Color	Function
Replay Cntr. Red Step-Up	B-25-925	C-26	83 20-1	Black-Yellow	Energizes step-up Coil.
Replay Cntr. Red Reset	C-28-1100	A-47	70 85-5	Orange Black-White	Energizes re-set coil.
Open at 96 N. C.	ASW-U2-3	E-26	71 65-11	Orange-Red Brown-White	Opens circuit to C. U. search disc.
Replay Cntr. Yellow Step-Up	B-25-925	C-25	31 41	Yellow-Red Green-Red	Energizes yellow replay counter step-up.
Replay Cntr. Yellow Reset	C-28-1100	A-47	70 85-5	Orange Black-White	Energizes yellow reset relay.
Open at 96 N. C.	ASW-U2-3	E-23	23 25	Blue-Yellow Blue-White	Opens circuit to C. U. search disc.
Replay Cntr. Green Step-Up	B-25-925	C-29	13-2 14-2	Red-Yellow Red-Green	Energizes green replay step up counter.
Replay Cntr. Green Reset	C-28-1100	A-48	70 85-5	Orange Black-White	Energizes replay counter reset coil.
Open at 96 N. C.	ASW-U2-3	E-32	61-6 81-6	Brown-Red Black-Red	Open circuit to extra card trip sw.
Replay Cntr. White Step-Up	B-25-925	C-29	13-2 14-2	Red-Yellow Red-Green	Energizes white replay step up counter.
Replay Cntr. White Reset	C-28-1100	A-48	70 85-5	Orange Black-White	Energizes replay counter reset coil.
Open at 96 N. C.	ASW-U2-3	E-32	61-6 81-6	Brown-Red Black-Red	Open circuit to extra card trip sw.

ALWAYS GIVE MODEL AND PART NO. WHEN ORDERING SERVICE PARTS

YEL., WHT., GRN. SCORE UNIT DISCS

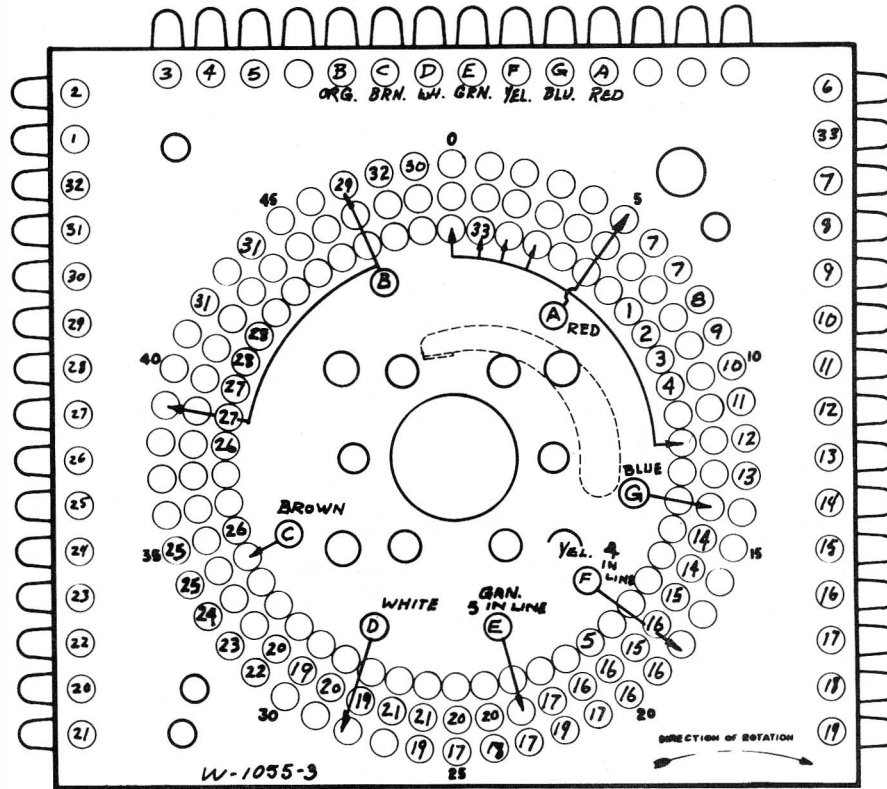

LUG	YEL.	GREEN	WHITE	
1	48-8	78-8	21	(4 & 8)
2	43-8	65-8	60	(5)
3	21-8	57-8	63	(6)
4	13-8	56-8	65-9	(7)
5	74-9	15-10	75-9	(8)
6	23-4	23-4	23-4	(Mixer #4 Re. Feed)
7	60-5	15-1	51-7	(4)
9	61-5	58	54-7	(8)
9	63-5	21-2	71-7	(16)
10	65-5	23-1	74-7	(32)
11	71-5	25-2	81-7	(64)
12	74-5	27-3	83-7	(128)
13	78-5	75-10	20-8	(192)
14	80-14	41-3	10-6	(4)
15	81-1	43-3	25-6	(8)
16	52-12	48-3	31-6	(16)
17	23-2	60-3	50-6	(24)
18	40-2	63-3	52-6	(36)
19	41-2	65-3	58-6	(50)
20	51-2	74-3	54-6	(75)
21	23	81-14	61-6	(Open at 96)
22	45-9	45-9	45-9	(4th)
23	27-5	27-5	27-5	(5th)
24	38-5	38-5	38-5	(6th)
25	40-5	40-5	40-5	(7th)
26	43-4	43-4	43-4	(X1 Replays)
27	52	52	52	(X4 Replays)
28	57	57	57	(X8 Replays)
29	60-6	60-6	60-6	(1st)
30	63-9	63-9	63-9	(3rd)
31	54-10	61-10	50-10	(Mixer #3)
A	30	30	30	(Lite Feeds)
B	75-8	80-11	40-12	(4 & 8 Odd Step Feeds)
C	41	14-2	43-7	(Multiple Feeds)
D	52-4	74-4	78-10	(Prob Odd Step Feeds)
E	61-3	61-3	61-3	(5 In Line Feeds)
F	83-8	19-9	57-5	(4 In Line Feeds)
G	54-3	58-6	10-5	(3 In Line Feeds)
32	10-7	10-7	10-7	(2nd Pos. 4 & 8 Odd Steps)
33		51-10		(Zero Pos. for Mixer #4 Re.)

NOTE: BLACK JUMPER IS REMOVED FOR THE GAME WITH THE NO. 1795 OR AFTER

RED SCORE UNIT

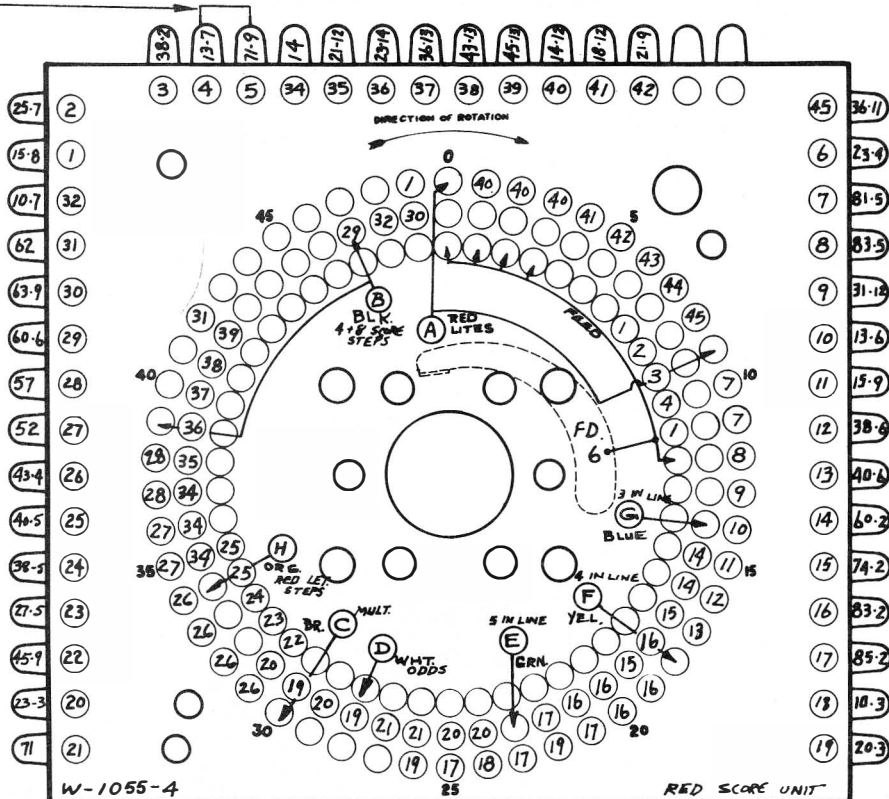

Switch/Coil	Part No.	Location on Diagram	Wire No.	Wire Color	Function
RED SCORE Step-Up	B-25-925	A-59	70 83 J	Orange Black-Yellow	Energizes step-up coil.
Red Score Reset	C-28-1100	A-46	70 50-2	Orange White	Energizes reset coil.
Open at "O" Sw. N. O.	ASW-U2	I-11	30 23-9	Yellow Blue-Yellow	Completes circuit to anti-cheat relay switch.
Open at Top Sw. N. C.	ASW-U2-5	A-59	83-4 83 J	Black-Yellow Black-Yellow	Opens circuit to step-up relay coil.
Step-Up Arm Sw. N. O.	ASW-U1-9	H-67	21-3 43-6	Blue-Red Green-Yellow	Completes circuit to score extra step relay coil.
Yellow Score Step-Up	B-25-925	A-58	70 18 J	Orange Red Black	Energizes step-up coil.
Yellow Score Reset	C-28-1100	A-44	70 78-3	Orange Orange-Black	Energizes reset coil.
Open at Top Sw. N. C.	ASW-U2-5	A-58	18-6 18 J	Red-Black Red-Black	Opens circuit to step-up coil.
Step-Up Arm Sw. N. O.	ASW-U1-9	H-67	21-3 43-6	Blue-Red Green-Yellow	Completes circuit to score extra step relay coil.
White Score Step-Up	B-25-925	A-61	70 63 J	Orange Brown-Yellow	Energizes score step-up coil.
White Score Reset	C-28-1100	A-45	70 78-3	Orange Orange-Black	Energizes score reset coil.
Open at Top Sw. N. C.	ASW-U2-5	A-61	63-6 63 J	Brown-Yellow Brown-Yellow	Opens circuit to step-up coil.
Step-Up Arm Sw. N. O.	ASW-U1-9	H-68	21-3 43-6	Blue-Red Green-Yellow	Completes circuit to score extra step relay coil.
Green Score Step-Up	B-25-925	A-60	70 57 J	Orange White-Orange	Energizes score step-up coil.
Green Score Reset	C-28-1100	A-45	70 78-3	Orange Orange-Black	Energizes score reset coil.
Open at Top Sw. N. C.	ASW-U2-5	A-60	57-11 57 J	White-Orange White-Orange	Opens circuit to step-up coil.
Step-Up Arm Sw. N. O.	ASW-U1-9	H-68	21-3 43-6	Blue-Red Green-Yellow	Completes circuit to score extra step relay coil.

ALWAYS GIVE MODEL AND PART NO. WHEN ORDERING SERVICE PARTS

RED LETTER UNIT

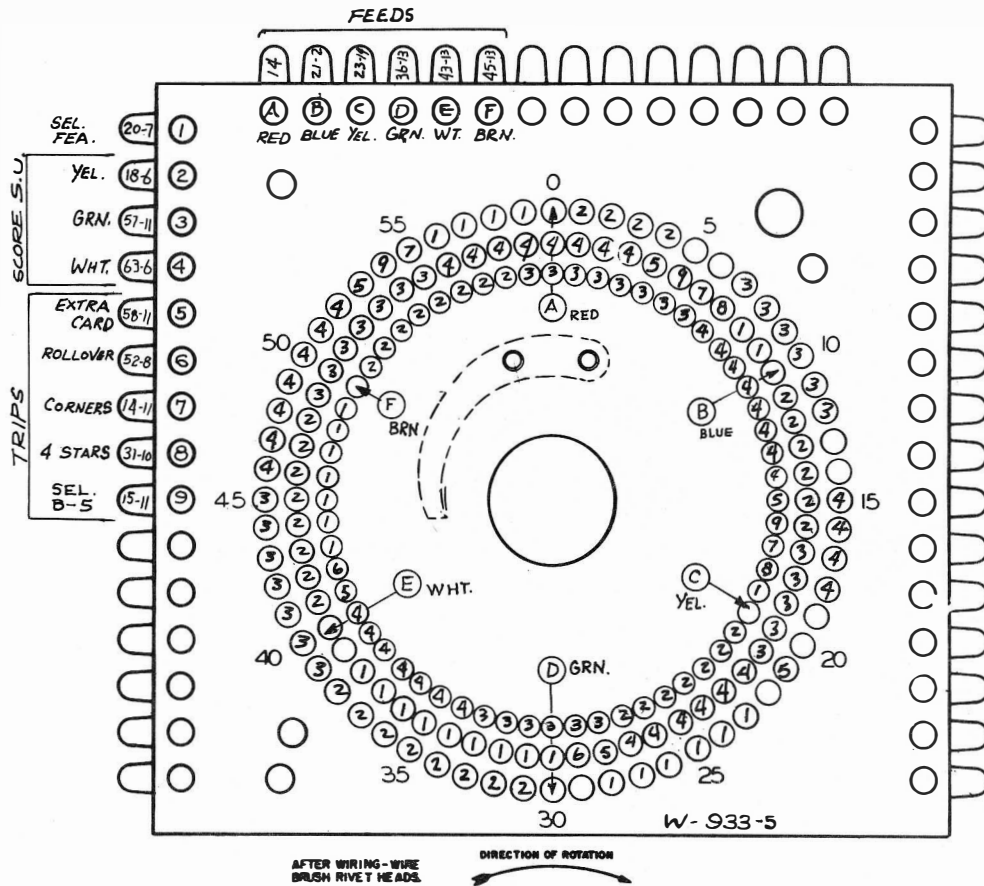

Switch/Coil	Part No.	Location on Diagram	Wire No.	Wire Color	Function
Red Letter Step-Up	B-25-925	A-71	70 27 J	Orange Blue-Orange	Energizes step-up coil.
Red Letter Reset	C-28-1100	A-43	70 78-3	Orange Orange-Black	Energizes reset coil.
Open at 29 Sw. N. C.	ASW-U2-5	A-71	27 J 27-14	Blue-Orange Blue-Orange	Opens circuit to step-up coil.

ALWAYS GIVE MODEL AND PART NO. WHEN ORDERING SERVICE PARTS

TIMER DISC

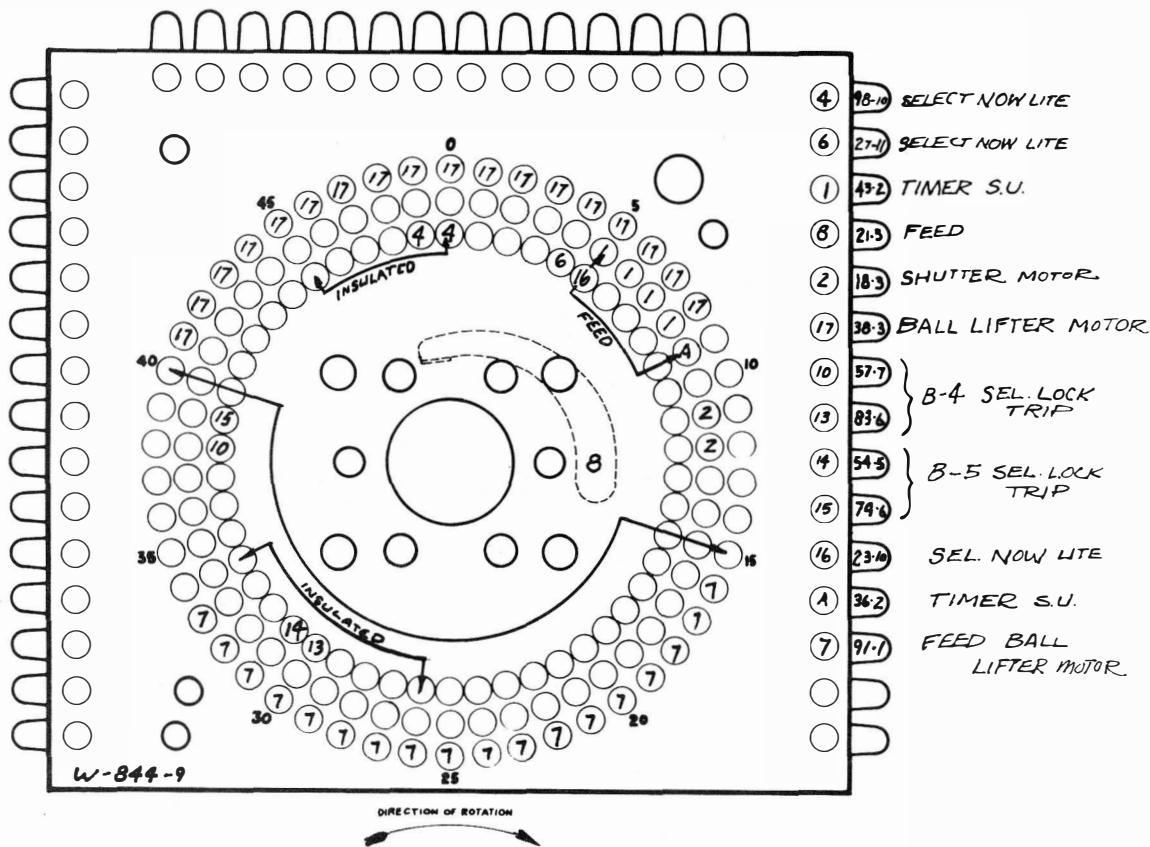

Switch/Coil	Part No.	Location on Diagram	Wire No.	Wire Color	Function
Timer Step-Up	B-25-925	A-13	70 14-13	Orange Red-Green	Energizes timer step-up coil.
Timer Reset	C-28-1100	A-14	70 85-5	Orange Black-White	Energizes Timer reset coil.
Open at "O" A. N. O.	ASW-U2	A-14	71-8 71J	Orange-Red Orange-Red	Completes circuit to timer reset coil.
Open at "O" B. N. O.	ASW-U2-1	H-43	30 48-10	Yellow Green-Black	Completes circuit to shutter motor cam #5 sw.
Open at "O" C. N. C.	ASW-U2-1	H-2	94-16 96-16	Grey-Green Grey-Brown	Open circuit to tilt trip sw.

ALWAYS GIVE MODEL AND PART NO. WHEN ORDERING SERVICE PARTS

EXTRA BALL UNIT DISC

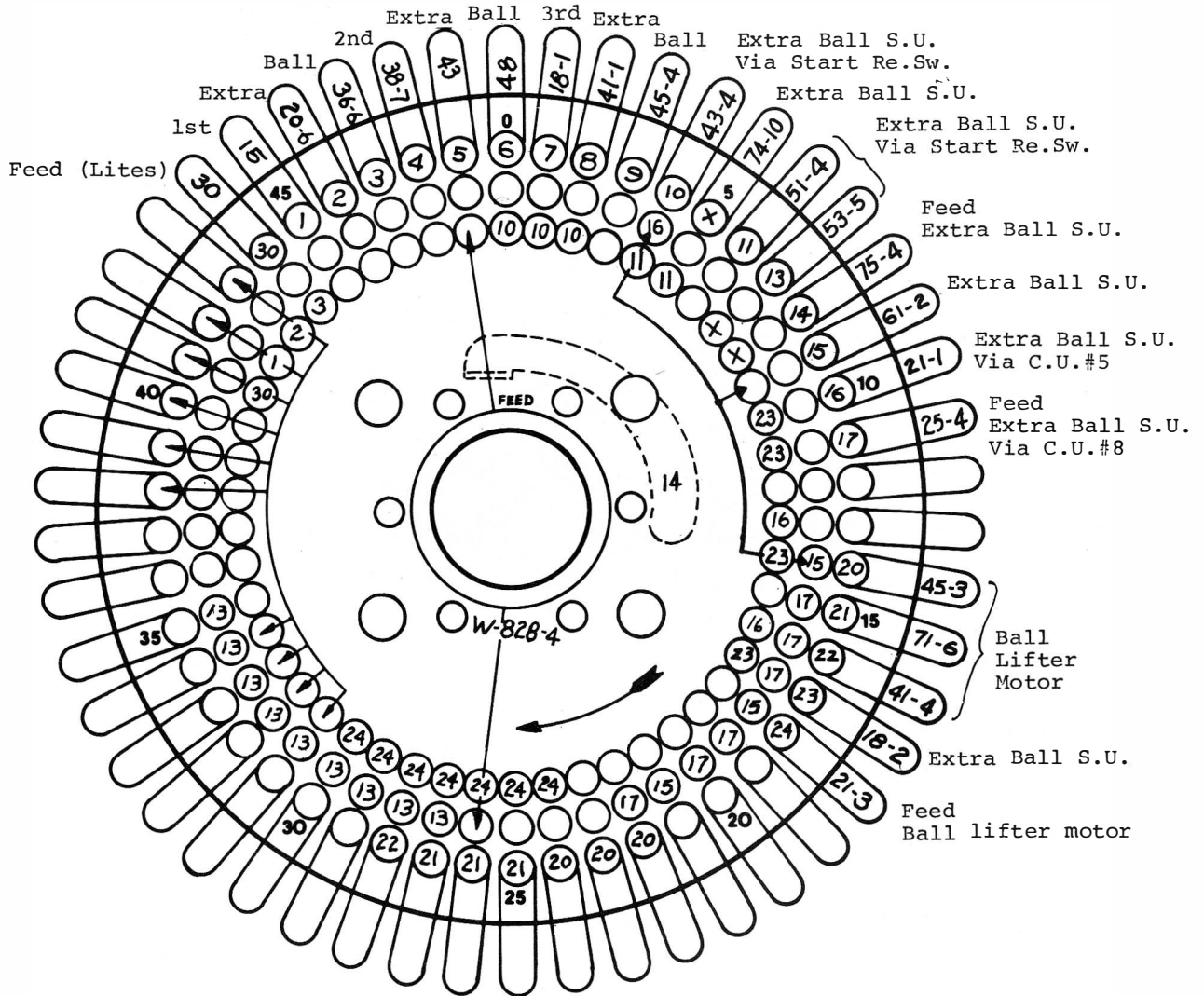

Switch/Coil	Part No.	Location on Diagram	Wire No.	Wire Color	Function
Extra Ball Step-Up	B-25-925	A-53	70 38-4	Orange Yellow-Black	Energizes extra ball step-up coil.
Extra Ball Reset	C-28-1100	A-46	70 85-5	Orange Black-White	Energizes extra ball reset coil.

Part No.	Description
AS-1148-36	Extra Ball Unit (complete)
W-828-4	Contact Plate Disc (wired)
AS-1046-786	Wiper Assembly
C-1050-1000	Ratchet & Shaft
B-25-925	Step-Up Coil
C-28-1100	Reset Coil
A-1765-4	Step-Up Arm

ALWAYS GIVE MODEL AND PART NO. WHEN ORDERING SERVICE PARTS

PANEL SHUTTER MOTOR UNIT PANEL LIFTER START RELAY

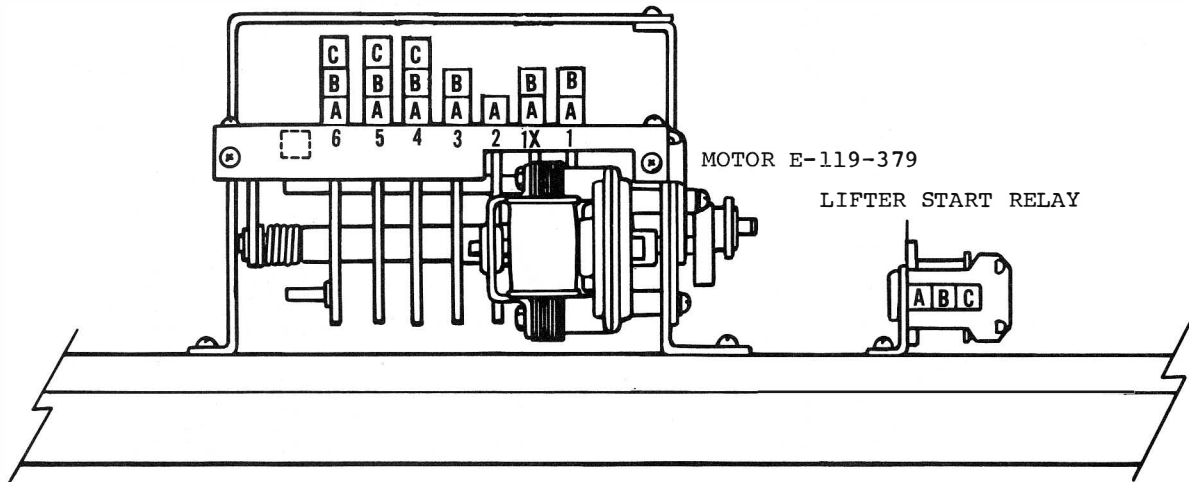

Name	Lifter Start Relay
Coil No.	G-32-2500
Coil Resist. Nominal	78 Ohm.
Operating Voltage	50 V.
Test Voltage	34 V.
Ext. Spring Part No.	White SP-199-28

SWITCH CODE

N. C.	Normally Closed
N. O.	Normally Open
M. B. B. . . .	Make Before Break
S. P. D. T. . .	Single Pole Double Throw

ALWAYS GIVE MODEL AND PART NO. WHEN ORDERING SERVICE PARTS

SHUTTER MOTOR & SWITCHES

Switch/Coil	Part No.	Location on Diagram	Wire No.	Wire Color	Function
SHUTTER MOTOR	E-119-379	A-11	70 14-3	Orange Red-Green	Energizes shutter motor
Cam #1 A. N. O.	ASW-C1-27	G-10	30 14-3	Yellow Red-Green	Completes circuit to shutter motor
Cam #1 B. N. C.	ASW-C2-15	I-68	21-3 63-13	Blue-Red Brown-Yellow	Opens circuit to shutter sw. (C. W. O.)
Cam #1X A. N. C.	ASW-C2-8	H-12	21-3 13	Blue-Red Red-Yellow	Opens circuit to shutter motor cam #5 Sw.
Cam #1X B. T.	ASW-C12-1	H-20	21-3 74-14 15-13	Blue-Red Orange-Green Red-White	Directs circuit through C. U. cam 13 sw. or through start relay sw. (15-13)
Cam #2 A. N. C.	ASW-C1-27	D-19	31-3 36-3	Yellow-Red Yellow-Brown	Opens circuit to ball detector relay sw.
Cam #3 A. N. O.	ASW-C1-2	G-46	85-5 30	Black-White Yellow	Completes circuit to extra ball reset coil & all 4 replay counter reset coils
Cam #3 B. N. O.	ASW-C1-8	G-9	83-14 30	Black-Yellow Yellow	Completes circuit to trip bank motor.
Cam #4 A. N. C.	ASW-C1-27	I-66	21-3 40-8	Blue-Red Green	Opens circuit to tilt trip sw. and lifter start relay sw.
Cam #4 B. N. O.	ASW-C2-15	F-11	45-8 18-3	Green-White Red-Black	Directs circuit to pad on timer disc & to shutter motor cam #4 sw. (C.W.O.)
Cam #4 C. N. O.	ASW-C2-2	E-11	14-3 18-3	Red-Green Red-Black	Completes circuit to shutter motor.
Cam #5 A. N. C.	ASW-C1-27	G-12	13 65-2	Red-Yellow Brown-White	Opens circuit to C. U. cam #5 sw. & C. U. Cam #1 Sw.
Cam #5 B. N. O.	ASW-C2-15	G-43	48-10 31-4	Green-Black Yellow-Red	Completes circuit to ball gate sw.
Cam #5 C. T.	ASW-C3-2	G-9	43-9 74-13 10-15	Green-Yellow Orange-Green Red	Directs circuit through C. U. Cam #1 sw. or extra ball #2 trip sw.
Cam #6 A. N. O.	ASW-C10-5	G-13	71-8 30	Orange-Red Yellow	Completes circuit to timer reset coil.
Cam #6 B. N. O.	ASW-C10-1	H-46	78-3 30	Orange-Black Yellow	Completes circuit to red letter, sel. fea., all 4 score reset coils (A-45)
Cam #6 C. N. O.	ASW-C10-1	H-9	83-14 30	Black-Yellow Yellow	Completes circuit to trip bank motor.
PANEL SW. A. N. O.	ASW-C2-11	G-68	63-13 31-8	Brown-Yellow Yellow-Red	Directs circuit to red letter win #2 Relay sw.
Panel Sw. B. N. C.	ASW-C1-29	B-11 38-12	14-3 38-12	Red-Green Yellow-Black	Opens circuit to shutter motor.
Panel Sw. C. N. C.	ASW-C1-29	C-32	25-14 48-12	Blue-White Green-Black	Opens circuit to red letter win #2 relay coil.
Panel Sw. D.	ASW-C111-3	G-38 G-42	21-3	Blue-Red	54, 53, 58-10, 23-7, 60-9, Directs circuits to magic line homing discs
LIFTER START	G-32-2500	A-43	70 38J	Orange Yellow-Black	Energizes relay coil.
A. N. O.	ASW-R1-8	D-43	36 38-8	Yellow-Brown Yellow-Black	Completes circuit to lifter start relay.
B. N. C.	ASW-R2-4	E-19	41-4 31-3	Green-Red Yellow-Red	Opens circuit to shutter motor cam #2 sw.
C. N. C.	ASW-R2-4	F-14	40-8 15-6	Green Red-White	Opens circuit to ball trough Sw. #3.
BALL RELAY Detector	G-32-2500	A-16	70 41-4	Orange Green-Red	Energizes Relay Coil
A. N. O.	ASW-R1-8	G-19	71-11 41-4	Orange-Red Green-Red	Completes ball detector relay coil & lifter start relay sw.
B. N. O.	ASW-R1-8	D-19	67 36-3	Brown-Orange Yellow-Brown	Completes circuit to manual lift button sw. & ball lifter sw.
C. N. C.	ASW-R2-4	H-17	21-3 20-13	Blue-Red Blue	Opens circuit to ball lifter #2 cam switch.

ALWAYS GIVE MODEL AND PART NO. WHEN ORDERING SERVICE PARTS

SHUTTER MOTOR & SWITCHES

Switch/Coil	Part No.	Location on Diagram	Wire No.	Wire Color	Function
BALL RUNWAY Sw. N. O.	ASW-A1-30	C-43	30 38-8	Yellow Yellow-Black	Completes circuit to lifter start relay.
Ball Gate Sw. N. C.	ASW-A2-5	E-43	31-4 36	Yellow-Red Yellow-Brown	Opens circuit to lifter start relay sw.
Rollover Sw. Yellow N. O.	ASW-A10-16	H-64	40-8 25-10	Green Blue-White	Completes circuit to C. U. alternator cam #9X.
Rollover Sw. Red N. O.	ASW-A10-16	G-65	40-8 61-9	Green Brown-White	Completes circuit to C. U. alternator cam #9X.
BALL TROUGH Sw. #1 N. O.	ASW-A1-95	E-18	41-4 71-6	Green-Red Orange-Red	Completes circuit to ball detector relay.
#2 N. O.	ASW-A1-96	F-18	45-3 71-6	Green-White Orange-Red	Completes circuit to ball trough sw. #1.
#3 A. N. C.	ASW-A1-96	D-13	15-6 54-5	Red-White White-Green	Opens circuit to timer unit disc.
#3 B. N. O.	ASW-A2-61	G-18	45-3 21-3	Green-White Blue-Red	Completes circuit to ball trough sw. #2.
#4 N. C.	ASW-A2-65	E-14	21-3 81-2	Blue-Red Black-Red	Opens circuit to ball lifter cam #2 Sw.
#8 N. O.	ASW-A1-95	B-19	25-12 38-3	Blue-White Yellow-Black	Completes circuit to ball lifter motor.
BALL LIFTER Motor	E-119-339	A-18	70 38-3	Orange Yellow-Black	Energizes ball lifter motor.
Cam #1 A. N. O.	ASW-C1X-3	E-19	30 25-12	Yellow Blue-White	Energizes ball lifter motor circuit.
Cam #1 B. N. O.	ASW-C1-23	H-19	21-3 71-11	Blue-Red Orange-Red	Completes circuit to ball detector relay.
Cam #2 A. N. O.	ASW-C1X-2	D-12	43-2 27-2	Green-Yellow Blue-Orange	Completes circuit to replay cams index sw.
Cam #2 B. N. O.	ASW-C1X-2	C-14	81-2 57-7	Black-Red White-Orange	Completes circuit to timer disc.
Cam #2 C. N. O.	ASW-C1X-2	G-17	20-13 14-5	Blue Red-Green	Completes circuit to tilt trip coil.

ALWAYS GIVE MODEL AND PART NO. WHEN ORDERING SERVICE PARTS

FRONT CABINET SWITCH ASSEMBLIES & COIL CHART

Switch/Coil	Part No.	Location on Diagram	Wire No.	Wire Color	Function
Yellow Button A. N. O.	ASW-A1-57	D-15	18-15 23-8	Red-Black Blue-Yellow	Completes circuit to before 5th sel. lock trip sw.
Yellow Button B. N. O.	ASW-A1-58	E-5	63-2 10-16	Brown-Yellow Red	Completes circuit to replay register "O" Sw.
Yellow Button C. N. C.	ASW-A2-30	D-14	60-13 85-7	Brown Black-White	Opens circuit to red button relay coil.
Red Button A. N. O.	ASW-A1-37	E-15	18-15 85-7	Red-Black Black-White	Completes circuit to red button relay coil.
Red Button B. N. O.	ASW-A1-62	F-5	51-11 10-16	White-Red Red	Completes circuit to replay register "O" Sw.
SEL. BUTTON "A" N. O.	ASW-A1-24	D-34	85-9 10-11	Black-White Red	Completes circuit to "A" motor
Sel. Button "B" N. O.	ASW-A1-24	D-35	85-9 20-11	Black-White Blue	Completes circuit to "B" motor.
Sel. Button "C" N. O.	ASW-A1-24	D-36	81-9 80-12	Black-Red Black	Completes circuit to "C" motor.
Sel. Button "D" N. O.	ASW-A1-24	D-37	74-12 40-11	Orange-Green Green	Completes circuit to "D" motor.
Sel. Button "E" N. O.	ASW-A1-24	D-38	15-4 50-11	Red-White White	Completes circuit to "E" motor.
"R" BUTTON A. N. O.	ASW-A111-2	C-24	52-5 21-3	White-Blue Blue-Red	Completes circuit to before 4th selector lock trip sw.
"R" Button B. N. O.		F-33	71-14 63-8	Orange-Red Brown-Yellow	Completes circuit to extra card trip sw.
"R" Button C. N. O.		H-13	31-13 21-3	Yellow-Red Blue-Red	Completes circuit to before 5th sel. lock trip sw.
Ball Lifter Sw. N. O.	ASW-A1-7	D-19	67 25-12	Brown-Orange Blue-White	Directs circuit to ball lifter motor via 3 sws. & timer unit disc, see diagram (B-18)
Button Lift A. N. O.	ASW-A2-9	D-18	67 25-12	Brown-Orange Blue-White	See Diag. (D-18) for various sw. circuit, ball lifter motor circuit.
Button Lift B. N. C.	ASW-A1-26	G-42	31-4 30	Yellow-Red Yellow	Opens circuit to ball gate sw.
Meter Lite		N-39	81 58-2	Black-Red White-Black	Meter lite circuit
Toggle Sw. N. O.	E-108-57	G-1	90-16 93-16	Grey- Grey-Yellow	Energizes 10 Amp fuse & transformer, 30 wire & 70 wire.
Tilt Sw. N. O.		G-17	14-5 21-3	Red-Green Blue-Red	Completes circuit to tilt trip coil.
FRONT DOOR Lite Sw. N. O.	ASW-M2-6	L-39	30 58-2	Yellow White-Black	Completes circuit to meter lite.
KEY SWS. A. N. C.	ASW-B1	B-5	13-12 85-12	Red-Yellow Black-White	Open circuit to start relay coil.
B. N. O.	ASW-B2	G-16	21-3 14-5	Blue-Red Red-Green	Completes circuit to tilt trip coil.
C. N. O.	ASW-B2	A-20	80-2 63-10	Black Brown-Yellow	Completes circuit to key meter coil.
D. N. O.	ASW-B2	C-20	78-14 50-5	Orange-Black White	Completes circuit to key sw. (End of stroke)
E. N. O.	ASW-B2	E-55	30 61-8	Yellow Brown-Red	Completes circuit to anti-cheat relay coil.
KEY SW. T.	ASW-C3-6	B-20	75-6 80-2 50-5	Orange-White Black White	Directs circuit to replay register step-up coil.
Front Door Tilt Sw. N. O.		G-17	14-5 21-3	Red-Green Blue-Red	Completes circuit to tilt trip sw.
Front Door Meter Sw.	(NOT USED)	A-21	70 40-4	Orange Green	(NOT USED)
Coin Sw. T.	AS-277-105	F-6	27-13 13-3 15-5	Blue-Orange Red-Yellow Red-White	13-3 Directs circuit to multi-play relay, 15-5 circuit part of start relay circuit.

ALWAYS GIVE MODEL AND PART NO. WHEN ORDERING SERVICE PARTS

SWITCH ASSEMBLIES & COIL CHART

Switch/Coil	Part No.	Location on Diagram	Wire No.	Wire Color	Function
REPLAY REGISTER	A-26-1100	A-20	70 80-2	Orange Black	Energizes replay register step-up.
Reset Coil	A-271100	A-4	70 45-11	Orange Green-White	Energizes replay register reset.
"O" Switch T.	ASW-U3-6	H-5	56-12 48-11 27-13	White-Brown Green-Black Blue-Orange	56-12 directs circuit to replay reset coil & register, 48-11 circuit to Start Relay Sw. #2 Trip Switch.
"O" Switch N. O.	ASW-J1-6	E-5	10-16 18-11	Red Red-Black	Completes circuit to replay reset switch.
Reflex Play	EA-32-1550	A-3	70 80-15	Orange Black	Energizes reflex play magnet coil.
Reflex Replay	EA-30-1150	A-22	70 41-9	Orange Green-Red	Energizes reflex replay magnet coil.
BACK DOOR Tilt Sw. N. O.	ASW-A1-25	G-17	14-5 21-3	Red-Green Blue-Red	Completes circuit to tilt trip relay.
METERSWITCH (not used)		B-21	51-72 40-4	White-Red Green	
Coin Lockout	M-37-2700	A-7	70 81-13	Orange Black-Red	Energizes Lockout Coil
Total Play Meter (In)	(NOT USED)	C-22	80-15 83-13	Black Black-Yellow	(NOT USED)
Total Replay Meter (Out)	(NOT USED)	C-21	41-9 78-1	Green-Red Orange-Black	(NOT USED)
Coin Meter	E-130-10	A-8	70 75-13	Orange Orange-White	Energizes coin meter coil.
Key Meter	E-130-10	A-20	70 63-10	Orange Brown-Yellow	Energizes key meter coil.

ALWAYS GIVE MODEL AND PART NO. WHEN ORDERING SERVICE PARTS

MOTOR PARTS GUIDE

CONTROL UNIT MOTOR E-119-462

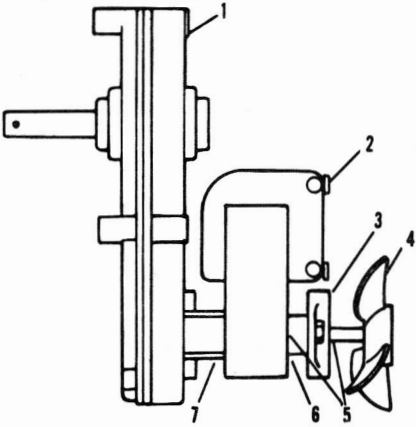

Index No.	Part No.	Description	No. Req.
1	GC3-4023-1	Transmission Unit	1
2	ASS-4023-1	Stator Unit	1
3	ABB-1010-00	Bearing & Brkt. Assy.	1
4	S-1011-01	Fan	1
Note: Order Index No.'s 5 - 7 as a unit			
5	AR3-4023-1	Rotor & Shaft Unit	1
6	W-1014-03	Rotor Shaft Washer	1
7	W-1017-25	Rotor Shaft Washer	1
	W-1016-03	Rotor Shaft Washer	1
	W-1016-12	Rotor Shaft Washer	3

TRIP BANK RELAY MOTOR E-119-464

Index No.	Part No.	Description	No. Req.
1	GC2-2543-1	Transmission Unit	1
2	AS2-2543-1	Stator Unit	1
3	ABB-1010-01	Bearing & Brkt. Assy.	1
Note: Order Index No.'s 4 - 6 as a unit			
4	AR2-2543-1	Rotor & Shaft Unit	1
5	W-1015-03	Rotor Shaft Washer	1
6	W-1014-03	Rotor Shaft Washer	1
	W-1014-09	Rotor Shaft Washer	3

PANEL SHUTTER MOTOR E-119-379

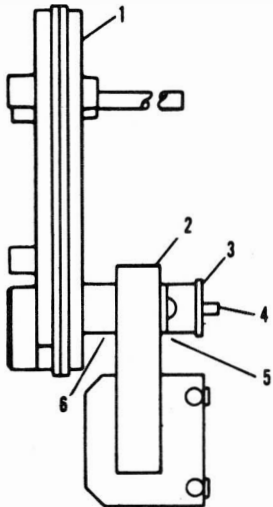

Index No.	Part No.	Description	No. Req.
1	GC2-1725-1	Transmission Unit	1
2	AS2-1725-1	Stator Unit	1
3	ABB-2010-01	Bearing & Brkt. Assy.	1
Note: Order Index No.'s 4 - 6 as a unit			
4	AR2-1725-1	Rotor & Shaft Unit	1
5	W-1015-03	Rotor Shaft Washer	1
6	J-1011-60	Shaft Shim Spring	1

BALL LIFTER MOTOR E-119-339

Index No.	Part No.	Description	No. Req.
1	GC2-1743-1	Transmission Unit	1
2	AS2-1743-1	Stator Unit	1
3	ABB-1010-1	Bearing & Brkt. Assy.	1
Note: Order Index No.'s 4 - 6 as a unit			
4	AR2-1743-1	Rotor & Shaft Unit	1
5	W-1015-03	Rotor Shaft Washer	1
6	J-1011-60	Shaft Shim Spring	1

Magic Line Motor E-119-475

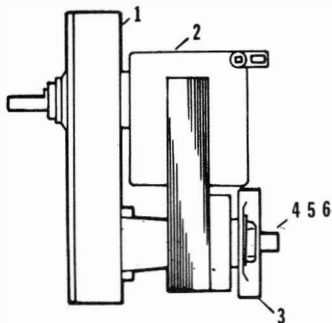

Index No.	Part No.	Description	No. Req.
1	GC1-1725-3	Transmission Unit	1
2	AS1-1725-3	Stator Unit	1
3	ABB-1010-01	Bearing Brkt. Assy.	1
4	AR1-1725-3	Rotor & Shaft Assy.	1
5	W-1015-03	Rotor Shaft Washer	1
6	J-1011-30	Rotor Shaft Spring	1

Note: Order No.'s 4 - 6 as a unit

ALWAYS GIVE MODEL AND PART NO. WHEN ORDERING SERVICE PARTS

MYSTIC LINES MOTOR UNIT DISCS

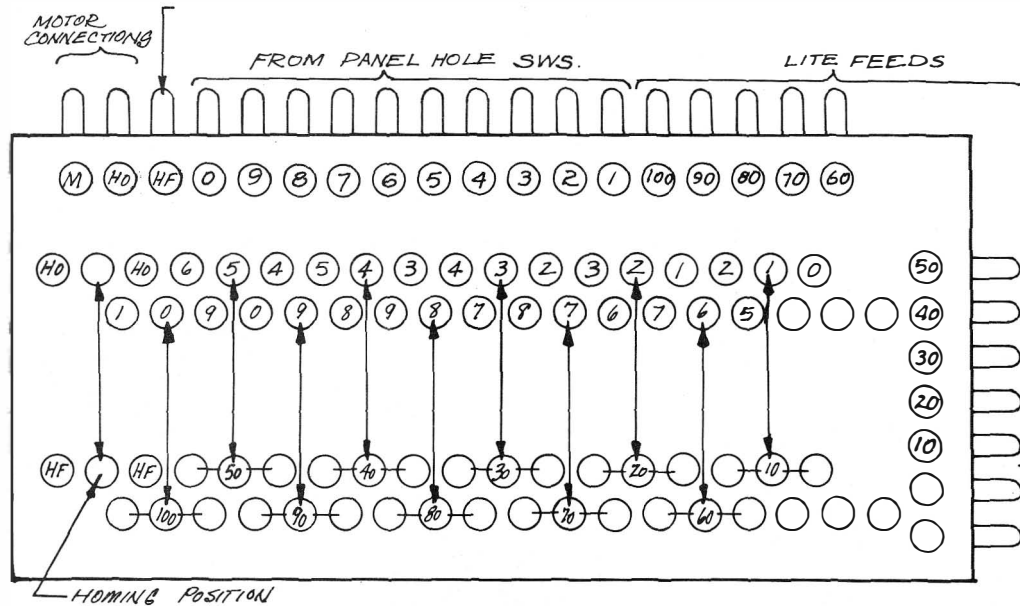

LUG NO.	A DISC		B DISC		C DISC		D DISC		E DISC	
	Panel Sw. No.	WIRE NO	Panel Sw. No.	WIRE NO	Panel Sw. No.	WIRE NO	Panel Sw. No.	WIRE NO	Panel Sw. No.	WIRE NO
M		70		70		70		70		70
HO		10-11		20-11		80-12		40-11		50-11
HF		60-9		23-7		58-10		53		54
0	(2)	75-1	(2)	75-1	(25)	36-1	(16)	54-1	(4)	61-1
9	(10)	56-1	(19)	52-1	(17)	74-1	(22)	78-4	(5)	31-1
8	(11)	85-3	(1)	27-1	(16)	54-1	(18)	51-1	(9)	48-1
7	(8)	38-1	(20)	71-1	(18)	51-1	(21)	50-1	(13)	25-1
6	(6)	45-1	(13)	25-1	(7)	53-1	(15)	63-1	(24)	57-1
5	(25)	36-1	(14)	40-1	(3)	43-1	(1)	27-1	(24)	57-1
4	(6)	45-1	(19)	52-1	(12)	65-1	(20)	71-1	(11)	85-3
3	(8)	38-1	(23)	60-1	(17)	74-1	(12)	65-1	(10)	56-1
2	(14)	40-1	(22)	78-4	(23)	48-1	(21)	50-1	(4)	61-1
1	(5)	31-1	(15)	63-1	(9)	60-1	(3)	43-1	(7)	53-1
100	(EE)	27	(F)	60-7	(00)	81-15	(P)	80-7	(YY)	48-6
90	(DD)	74-15	(G)	61-7	(NN)	85-8	(Q)	81-10	(XX)	51-14
80	(CC)	61	(H)	63-7	(MM)	58-12	(R)	83-10	(WW)	21-6
70	(BB)	14-1	(I)	27-6	(LL)	80-3	(S)	18-13	(VV)	80-5
60	(AA)	13-11	(J)	13-10	(KK)	40-3	(T)	71-13	(UU)	23-5
50	(E)	56-7	(FF)	85-1	(O)	78-7	(PP)	83-11	(Y)	45
40	(D)	48-7	(GG)	31-2	(N)	75-7	(QQ)	10-4	(X)	14-4
30	(C)	50-7	(HH)	53-2	(M)	25-5	(RR)	18-4	(W)	36-4
20	(B)	45-7	(II)	57-2	(L)	21-10	(SS)	27-4	(v)	50-8
10	(A)	36-7	(JJ)	78-2	(K)	52-7	(TT)	57-4	(U)	83-1

(5)	(14)	(8)	(6)	(25)
A	B	C	D	E
(2)	(19)	(1)	(20)	(13)
F	G	H	I	J
(23)	(9)	(17)	(12)	(3)
K	L	M	N	O
(16)	(22)	(18)	(21)	(7)
P	Q	R	S	T
(15)	(4)	(10)	(11)	(24)
U	V	W	X	Y

MAIN CARD
(HOMING POSITION)

(6)	(8)	(11)	(10)	(12)
AA	BB	CC	DD	EE
(14)	(19)	(23)	(22)	(7)
FF	GG	HH	II	JJ
(15)	(18)	(16)	(17)	(25)
KK	LL	MM	NN	OO
(1)	(20)	(12)	(21)	(3)
PP	QQ	RR	SS	TT
(24)	(13)	(9)	(5)	(4)
UU	VV	WW	XX	YY

EXTRA CARD
(HOMING POSITION)

PARTS GUIDE

FRONT DOOR ASSEMBLY

Part No.	Description
AS-2041-83	Front Door Assembly (complete)
M-281-54	Lock
A-254-117	Hinge Assembly
M-1400-Series	Slug Rejector (specify Coin)
AS-2517-14	Coin Lockout Magnet
P-6431-Series	Coin Guide Spacer (specify coin)
P-6694-Series	Coin Guide (specify coin)
A-1729-16	Push Button Assy. (replay)
P-800-2	Washer
P-2891-7	Retaining Ring
ASW-A1-15	Replay Sw.
ASW-A1-27	Tilt Sw.

FRONT MOLDING ASSEMBLY

Part No.	Description
AS-1305-63	Front Molding Assy. (complete)
P-2210-Coin	Coin Drop Plate
A-1272-23	"A" Button & Pin Assy.
A-1272-24	"B" Button & Pin Assy.
A-1272-25	"C" Button & Pin Assy.
A-1272-26	"D" Button & Pin Assy.
A-1272-27	"E" Button & Pin Assy.
A-1272-29	"R" Button & Pin Assy.
SP-200-111	Button Compression Spring
P-801-214	Washer (Buttons)
P-448-6	Snap Washers (Buttons)

PLAYFIELD PANEL

Part No.	Description
AS-2042-184	Panel Assembly (complete)
CA-638-99	Panel
CA-1100-9	Arch Bottom
CA-1103	Arch Guide Strip
CA-1104	Arch Top
CA-529-13	Shutter
C-326-9	Light Shield Post (8) (white)
E-125-2	Light Bulb #47 (8)
M-170	Rebound Coil Spring (8)
SP-112-1	Short Panel Spring (4)
SP-112	Long Panel Spring (8)
S-1071-84	Panel Pins (29)
C-119-21	Red Bumper Post (4)
R-243-2	Red Bumper Rubber (4)
C-119-23	Yellow Bumper Post (30)
R-243	Yellow Bumper (26)
R-135	Double Bumper Rubber (2)
R-115-30	Rebound Rubber Top
C-153	Red Plastic Ball Lift Cover

FRONT CABINET

Part No.	Description
CA-1119-53	Front Cabinet
M-281-58	Lock (Replay Switch)
AS-982-673	Top Replay Switch
AS-982-671	Bottom Replay Sw.
A-1533	Coin Slide Assembly
AS-186-11	Ball Lifter Assembly
AS-187-17	Ball Shooter Assembly
A-100-7	Knob & Shooter Rod
SP-243	Compression Spring 1"
SP-200-24	Compression Spring 6"
R-108-3	Shooter Tip
P-2891-8	Retaining Ring
E-108-57	Game On - Off Switch
A-2618	Legs
M-106-1	Leg Bolt (8)
M-163-4	Leg Adjuster
N3-816-1110	Leg Adj. Nut
A-2790-59	Cash Box
P-3089-55	Cash Box Cover
P-921-39	Chrome Glass Molding - Lf.
P-921-40	Chrome Glass Molding - Rt.
G-213	Top Glass
CA-439-28	Ball Return Panel

BACK CABINET

Part No.	Description
G-292-40	Back Glass
CA-1120-52	Back Cabinet (painted)
M-281-74	Lock (Back Glass)
E-126-63	Cord Set
A-3400-241	Insert & Socket Assembly
E-125-5	Light Bulb No. 55 (64)
E-125-2	Light Bulb No. 47 (17)

BACK DOOR ASSEMBLY

Part No.	Description
CA-1120-9	Back Door (painted)
P-2335-48	Hinge (2)
M-281-24	2 Lock Set
P-758-31	Lock Cam (2)

MAINTENANCE & SERVICE SUGGESTIONS

To maintain a Game in good working order the game should be kept as clean as possible. Starting with the Coin Chute, for a great deal of Dirt, Metallic Coin Dust, and sticky beverages collect here. An aerosol type de-greaser or contact cleaner can be used, however all parts must be wiped off with a clean cloth to remove any residue & dissolved scum, especially on electrical contacts & printed Circuit Disc.

Keeping the Bottom Cabinet and Back Cabinet free and clear of extra loose parts, screws, nuts, and switch blades, eases trouble shooting; for broken or loose parts often turn up at the bottom of the cabinets making the troubled area easier to identify and correct.

Proper adjustments on Sw. Blades and Wipers should be maintained for proper electrical conduction and machine timing. Overly bent Sw. Blades will break off at the base. Wiper blades under too much pressure will cut through printed circuit discs. Wiper assemblies especially those assembled with multiple fibre discs are very susceptible electrical arcing when covered with even a thin coat of dirt & oil. Arcing will cause carbon traces to build up which will burn a hole through the fibre plates. Arcing shorts are hard to trace and play havoc with a circuit. Arcing can be checked for by giving discs and wipers a physical check.

Also check fibre cams for worn lobes or worn locking notches. In conclusion a clean machine is easier to maintain and keep in service.

GUARANTEED Red-Letter Games. BE SURE to register replays scored in Red, Blue, Yellow and Green Zones BEFORE holding "R"-Button to start Red-Letter Game

SCORES ADVANCE TO				SCORES ADVANCE TO				SCORES ADVANCE TO				SCORES ADVANCE TO				SCORES ADVANCE TO				SCORES ADVANCE TO			
RED	YELLOW	GREEN	WHITE	RED	YELLOW	GREEN	WHITE	RED	YELLOW	GREEN	WHITE	RED	YELLOW	GREEN	WHITE	RED	YELLOW	GREEN	WHITE	RED	YELLOW	GREEN	WHITE
75 or 96	96	300	96	96	300	200	300	200	400	300	400	300	600	400	400	400	600	400	600	600	600	600	600
16 or 24	50	144	50	50	144	96	144	96	192	144	192	144	400	192	192	192	400	192	400	400	400	400	400
4 or 8	16	64	16	16	64	32	64	32	128	64	128	64	192	128	128	128	192	128	192	192	192	192	192
EXTRA CARD LIGHTS A-B-C				EXTRA CARD LIGHTS A-B-C-D				EXTRA CARD LIGHTS A-B-C-D				EXTRA CARD LIGHTS A-B-C-D-E				EXTRA CARD LIGHTS A-B-C-D-E				EXTRA CARD LIGHTS A-B-C-D-E			
ROLL-OVER LIGHTS				ROLL-OVER LIGHTS				ROLL-OVER LIGHTS				BEFORE 5TH LIGHTS CORNERS LIGHTS				BEFORE 5TH LIGHTS CORNERS LIGHTS				BEFORE 5TH LIGHTS CORNERS LIGHTS 4 STARS' LIGHTS			

AMER-SUPREME

A GAME OF SKILL FOR AMUSEMENT ONLY. NO PRIZES OR GAMBLING PERMITTED. SCORE VOID IF GAME IS TILTED.

MAS-3

FIRST PRESS RED BUTTON AND DEPOSIT COIN TO START GAME

TO LIGHT ADDED FEATURES AND ADVANCE SCORES DEPOSIT ADDITIONAL COINS

TO PLAY FOR EXTRA BALLS PRESS YELLOW BUTTON AND DEPOSIT ADDITIONAL COINS

TO PLAY REPLAYS SIMPLY PRESS BUTTONS WITHOUT DEPOSITING COINS

WHEN GAME IS COMPLETED

PRESS **R** BUTTON

To Start Red-Letter Game Hold R-Button Down Until All Balls Drop

FOR AMUSEMENT ONLY NO PRIZES OR GAMBLING PERMITTED

SHOOT TO LIGHT ADJOINING NUMBERS CONNECTED BY RED, YELLOW, GREEN OR WHITE LINES

RED LINE SCORES

5-IN-LINE	75	96	96	200	300	400	600
4-IN-LINE	16	24	50	96	144	192	400
3-IN-LINE	4	8	16	32	64	128	192

YELLOW LINE SCORES

5-IN-LINE	75	96	96	200	300	400	600
4-IN-LINE	16	24	50	96	144	192	400
3-IN-LINE	4	8	16	32	64	128	192

GREEN LINE SCORES

5-IN-LINE	75	96	96	200	300	400	600
4-IN-LINE	16	24	50	96	144	192	400
3-IN-LINE	4	8	16	32	64	128	192

WHITE LINE SCORES

5-IN-LINE	75	96	96	200	300	400	600
4-IN-LINE	16	24	50	96	144	192	400
3-IN-LINE	4	8	16	32	64	128	192

ONLY HIGHEST SCORE PER COLOR SCORES

MISS AMERICA '77-2